



Safety glasses should be worn at all times while installing this product.

YEARS: 2008-PRESENT

MAKE: HONDA & ACURA

MODEL: ACCORD & TSX SPORT WAGON

STYLE: SEDAN, COUPE, & WAGON

WARNING: NEVER EXCEED YOUR VEHICLE MANUFACTURER'S RECOMMENDED TOWING CAPACITY

WEIGHT CARRYING:
 TRAILER WEIGHT: 2,000 LBS.
 TONGUE WEIGHT: 200 LBS.

WARNING:
 WE RECOMMEND THE USE OF 18050 STABILIZING STRAPS FOR ALL NON-TRAILER (WHEEL-LESS) LOADS. PLEASE SEE THE CURT CATALOG OR VISIT US ONLINE AT WWW.CURTMFG.COM FOR FURTHER INFORMATION.

INSTALLATION TIME: 45 MIN.

THE INSTALL TIME LISTED IS FOR PROFESSIONAL INSTALLERS. IF YOU ARE HESITANT TO UNDERTAKE THIS TASK ON YOUR OWN, CONTACT AN AUTHORIZED CURT INSTALLER FOR ADDITIONAL ASSISTANCE.



INSTALLATION REQUIRES:

 RATCHET	 TORQUE WRENCH	 10mm 9/16" 11/16" SOCKET
 DIE GRINDER	 AVIATION SHEARS	

INSTALLATION TIPS:

- BEFORE YOU BEGIN INSTALLATION, READ ALL INSTRUCTIONS THOROUGHLY.
- TO EASE INSTALLATION, 2 PEOPLE MAY BE REQUIRED.
- USING PROPER TOOLS WILL GREATLY IMPROVE THE QUALITY OF THE INSTALL AND REDUCE THE TIME REQUIRED.
- NEED HELP OR HAVE SOME QUESTIONS? CALL TECHNICAL SUPPORT AT 800.798.0813

LEVEL OF DIFFICULTY: MODERATE

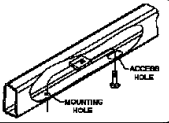
EASY	MODERATE	CHALLENGING
	- HOLE ENLARGEMENT REQUIRED	
	- TRIM HEAT SHIELD	
	- FISHWIRE HARDWARE	

VEHICLE PHOTO:



REPRESENTATIVE PHOTO

HITCH ILLUSTRATION:

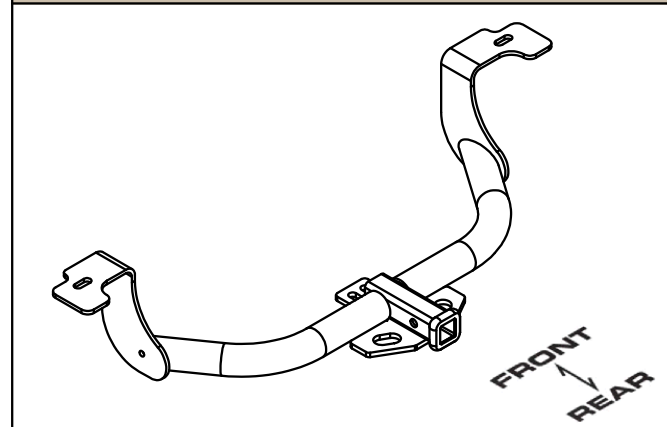

MAKE SURE YOUR HITCH MATCHES

PERIODICALLY CHECK THIS RECEIVER HITCH TO ENSURE ALL FASTENERS ARE TIGHT AND ALL STRUCTURAL COMPONENTS ARE SOUND

CURT Manufacturing LLC. warrants this product to be free of defects in material and/or workmanship at the time of retail purchase by the original purchaser. If the product is found to be defective, Curt Manufacturing LLC. may repair or replace the product at their option, when the product is returned, prepaid, with proof of purchase. Alteration to, misuse of, or improper installation of this product voids the warranty. Curt Manufacturing LLC.'s liability is limited to repair or replacement of products found to be defective, and specifically excludes liability for incidental or consequential loss or damage.

For more information log onto www.curtmfg.com, & for helpful towing tips log onto www.hitchinfo.com

INSTALLATION WALKTHROUGH:

Parts List			
ITEM	QTY	PART NUMBER	DESCRIPTION
1	2	HFN3816	HEX FLANGE NUT
2	2	7/16-14	HEX FLANGE NUT
3	2	CM-SP11	.250 x 1.00 x 2.50" SQUARE HOLE SPACER
4	2	7/16-14 x 1 1/2	CARRIAGE BOLT
5	2	7_16 FISHWIRE	7/16" FISHWIRE
6	1	3_8 - 16 x 1.00 x 1.88	U-BOLT

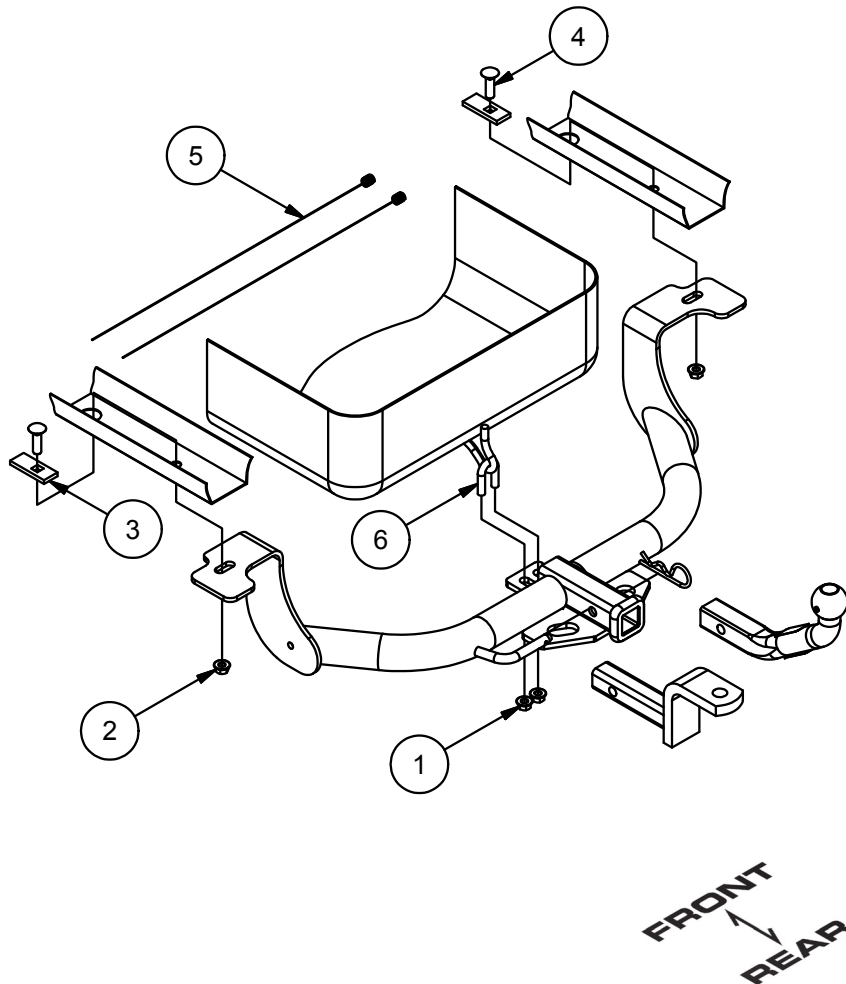

1. Lower exhaust by removing (2) rubber isolators for single exhaust vehicles and (4) isolators for dual exhaust vehicles.

RUBBER ISOLATOR REMOVAL DIAGRAM

This technique can be used if an Exhaust Hanger Removal Pliers is not available.

Using a 5/8" open end wrench, slide the wrench up to the rubber isolator, cradling the hanger rod as shown. Next place the flat edge of a pry bar between the wrench and the hanger stop or hanger rod. Then simply rotate the pry bar toward the wrench to remove the rubber isolator.

Note: Using a spray lubricant or soapy water on the hanger rod and the rubber isolator helps removal.

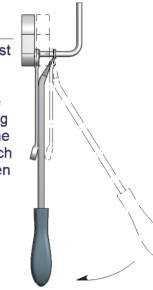

2. Remove heat shield(s) by removing (4) screws per shield. Save screws and shield(s) for reinstallation later.



INSTALLATION WALKTHROUGH:

3. If present, remove the underbody panel and trim. Save panel and fasteners for reinstallation later.
Note: Dimensions are approximate, confirm fit prior to trimming.

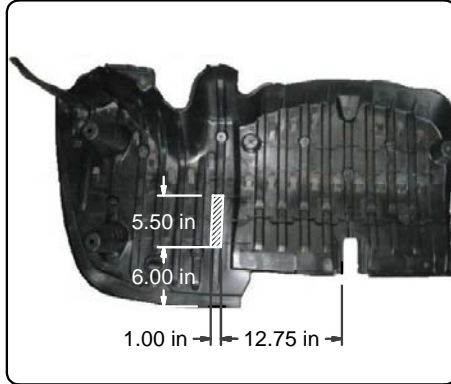

4. Check if hardware can be inserted through access holes in frame rails. If not, enlarge the holes with a die grinder or rotary tool until hardware can pass through.



5. Fishwire 7/16-14 x 1 1/2" carriage bolts and CM-SP11 spacers through access holes and out mounting holes in both frame rails.

FISHWIRE TECHNIQUE
INSERT COILED END OF FISHWIRE TOOL THROUGH HITCH MOUNTING HOLE IN VEHICLE FRAME RAIL AND OUT THE ACCESS HOLE. PASS COILED END OF FISHWIRE THROUGH SPACER AND THREAD BOLT INTO COIL. KINK WIRE TO KEEP SPACER SEPARATE FROM BOLT AS SHOWN. PULL FISHWIRE, SPACER, AND BOLT THROUGH FRAME AND OUT MOUNTING HOLE. USE FISHWIRE TO GUIDE HITCH DURING MOUNTING AND PREVENT LOSS OF BOLT / SPACER INSIDE FRAME RAIL.
NOTE: SOME VEHICLES MAY FISHWIRE THROUGH END OF FRAME

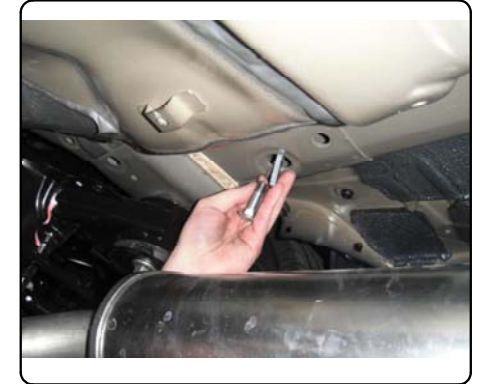
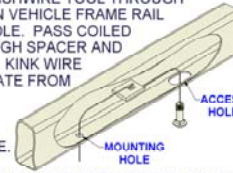

6. Insert 3/8" U-bolt through tow loop. Raise hitch into position and secure it with 7/16-14 hex flange nuts on the carriage bolts and 3/8-16 hex flange nuts on the U-bolt. If underbody panel is present you will need to raise it with the hitch.



INSTALLATION WALKTHROUGH:

7. Torque all 7/16" hardware to 50 ft-lbs.
Torque all 3/8" hardware to 30 ft-lbs.
Note: If underbody panel is present you will need to reach underneath it to torque the driver side bolt.



8. Trim heat shield(s) around hitch. Reinstall heat shield(s) with hardware removed in Step (2). **Note:** Dimensions are approximate, confirm fit prior to trimming.

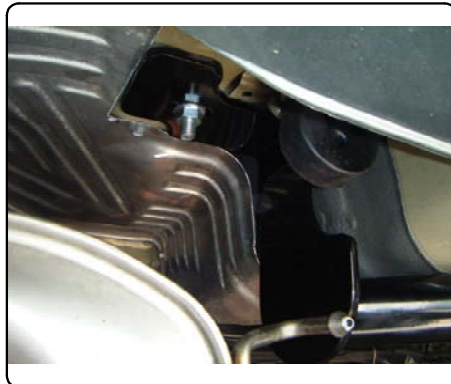
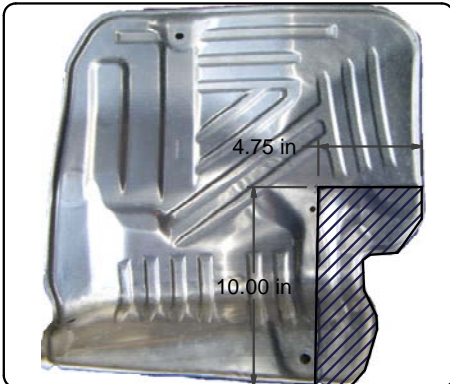

9. Raise exhaust and reattach rubber isolators. If under body panel is present, resecure using fasteners removed in Step (3).
INSTALL COMPLETE.



11085

HONDA ACCORD SEDAN & COUPE / ACURA TSX SPORT WAGON

8/15/2011

GROSS LOAD CAPACITY WHEN USED AS A WEIGHT CARRYING HITCH: 2,000 LBS. TRAILER WEIGHT & 200 LBS. TONGUE WEIGHT.

DO NOT EXCEED VEHICLE MANUFACTURER'S RECOMMENDED TOWING CAPACITY.

WARNING: ALL NON-TRAILER LOADS APPLIED TO THIS PRODUCT MUST BE SUPPORTED BY 18050 STABILIZING STRAPS.

** FAILURE TO PROPERLY SUPPORT NON-TRAILER LOADS WILL VOID PRODUCT WARRANTY**

HAVING INSTALLATION QUESTIONS? CALL TECHNICAL SUPPORT AT 1-800-798-0813

Parts List				
ITEM	QTY	PART NUMBER	DESCRIPTION	
1	2	7/16-14	HEX FLANGE NUT	
2	2	7/16-14 x 1 1/2	CARRIAGE BOLT	
3	2	CM-SP11	.250 x 1.00 x 2.50" SQUARE HOLE SPACER	
4	2	7_16 FISHWIRE	7/16" FISHWIRE	
5	2	HFN3816	HEX FLANGE NUT	
6	1	3_8 - 16 x 1.00 x 1.88	U-BOLT	

HOLE ENLARGEMENT WITH DIE GRINDER / ROTARY TOOL

CHECK IF HARDWARE WILL FIT THROUGH ACCESS HOLE. IF NOT, USE A GRINDER / DREMEL TO OBLONG THE HOLE AS SHOWN ABOVE TO ALLOW THE FASTENERS TO PASS THROUGH.

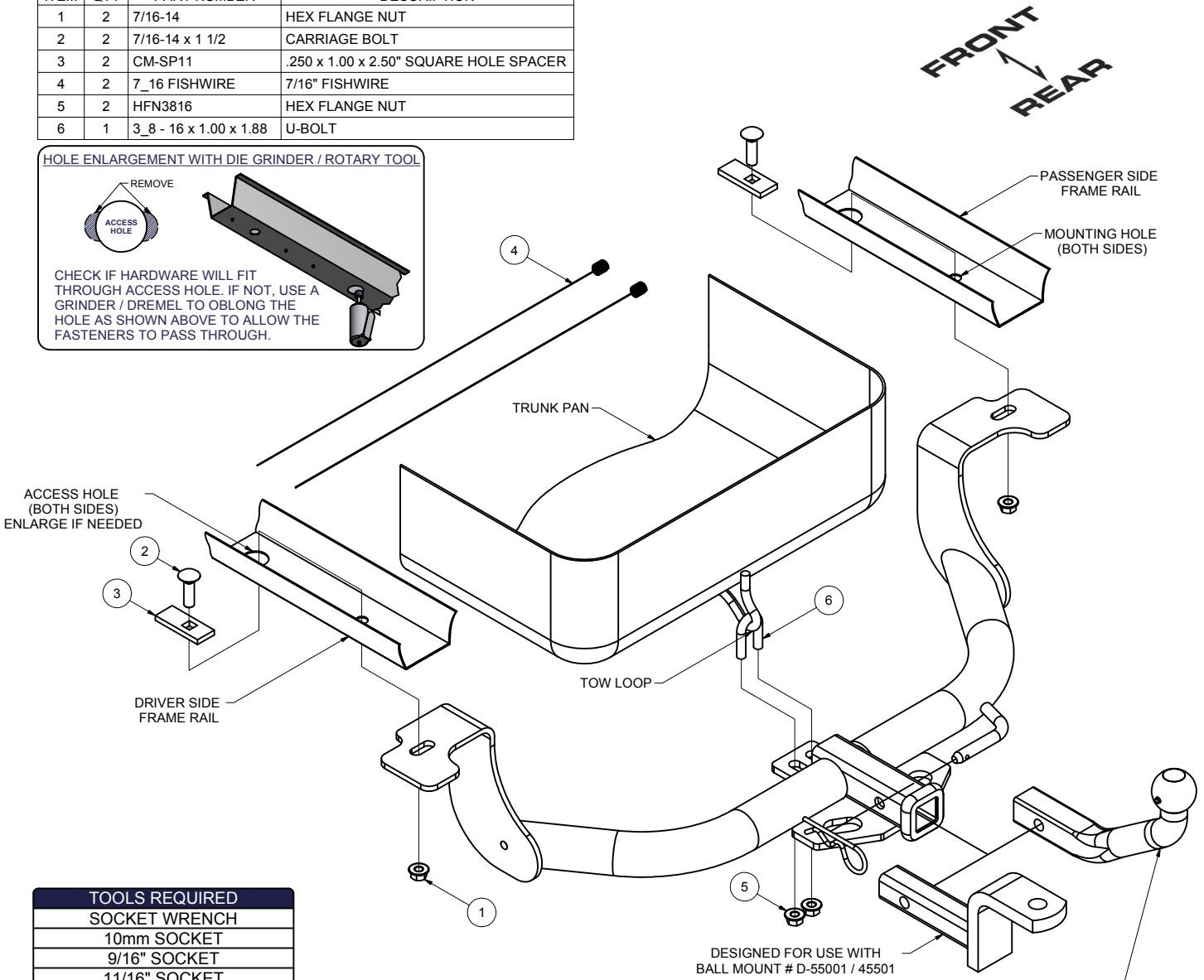

DESIGNED FOR USE WITH BALL MOUNT # D-55001 / 45501

EURO MOUNT OPTION AVAILABLE #45571 (1-7/8" BALL) AND #45572 (2" BALL)

TOOLS REQUIRED
SOCKET WRENCH
10mm SOCKET
9/16" SOCKET
11/16" SOCKET
TORQUE WRENCH
DIE GRINDER/ROTARY TOOL
AVIATION SHEARS

RUBBER ISOLATOR REMOVAL DIAGRAM

This technique can be used if and Exhaust Hanger Removal Pliers is not available.

Using a 5/8" open end wrench, slide the wrench up to the rubber isolator, cradling the hanger rod as shown. Next place the flat edge of a pry bar between the wrench and the hanger stop or hanger rod. Then simply rotate the pry bar toward the wrench to remove the rubber isolator.

Note: Using a spray lubricant or soapy water on the hanger rod and the rubber isolator helps removal.

FISHWIRE TECHNIQUE

INSERT COILED END OF FISHWIRE TOOL THROUGH HITCH MOUNTING HOLE IN VEHICLE FRAME RAIL AND OUT THE ACCESS HOLE. PASS COILED END OF FISHWIRE THROUGH SPACER AND THREAD BOLT INTO COIL. KINK WIRE TO KEEP SPACER SEPARATE FROM BOLT AS SHOWN. PULL FISHWIRE, SPACER, AND BOLT THROUGH FRAME AND OUT MOUNTING HOLE. USE FISHWIRE TO GUIDE HITCH DURING MOUNTING AND PREVENT LOSS OF BOLT / SPACER INSIDE FRAME RAIL.

NOTE: SOME VEHICLES MAY FISHWIRE THROUGH END OF FRAME

HITCH WEIGHT: 23 LBS.

INSTALL TIME

PROFESSIONAL: 45 MINUTES

NOVICE (DIY): 90 MINUTES

INSTALL NOTES:

- HOLE ENLARGEMENT REQUIRED
- HEAT SHIELD TRIMMING REQUIRED
- FISHWIRE HARDWARE

PERIODICALLY CHECK THIS RECEIVER HITCH TO ENSURE THAT ALL FASTENERS ARE TIGHT AND THAT ALL STRUCTURAL COMPONENTS ARE SOUND.

Curt Manufacturing Inc., warrants this product to be free of defects in material and/or workmanship at the time of retail purchase by the original purchaser. If the product is found to be defective, Curt Manufacturing Inc., may repair or replace the product, at their option, when the product is returned, prepaid, with proof of purchase. Alteration to, misuse of, or improper installation of this product voids the warranty. Curt Manufacturing Inc.'s liability is limited to repair or replacement of products found to be defective, and specifically excludes liability for incidental or consequential loss or damage.

11085**HONDA ACCORD SEDAN & COUPE / ACURA TSX SPORT WAGON**

GROSS LOAD CAPACITY WHEN USED AS A WEIGHT CARRYING HITCH: 2,000 LBS. TRAILER WEIGHT & 200 LBS. TONGUE WEIGHT.

*****DO NOT EXCEED VEHICLE MANUFACTURER'S RECOMMENDED TOWING CAPACITY.*****

WARNING: ALL NON-TRAILER LOADS APPLIED TO THIS PRODUCT MUST BE SUPPORTED BY AUXILIARY STABILIZING STRAPS.

**** FAILURE TO PROPERLY SUPPORT NON-TRAILER LOADS WILL VOID PRODUCT WARRANTY****

HAVING INSTALLATION QUESTIONS? CALL TECHNICAL SUPPORT AT 1-800-798-0813

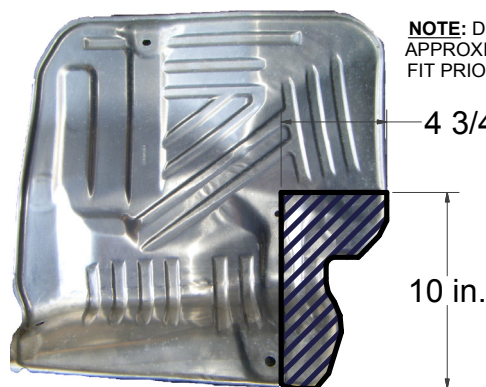
HEAT SHIELD TRIMMING DIAGRAM

NOTE: DIMENSIONS ARE APPROXIMATE, CONFIRM FIT PRIOR TO TRIMMING.

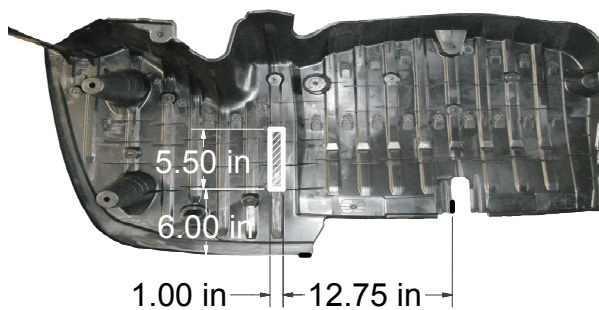
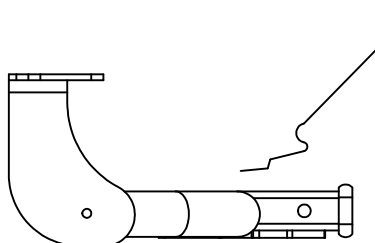
UNDERBODY PANEL TRIM DIAGRAMINSTALLED HITCH POSITION**INSTALLATION STEPS**

1. Lower exhaust by removing two (2) rubber exhaust isolators for single exhaust vehicles and four (4) isolators for dual exhaust vehicles. (See RUBBER ISOLATOR REMOVAL DIAGRAM.)
2. Remove heat shield(s) by removing four (4) screws per shield. Save screws and shields for reinstallation later.
3. If present, remove the underbody panel and trim. Save panel and fasteners for reinstallation later. (See UNDERBODY PANEL TRIM DIAGRAM)
4. Check if hardware can be inserted through access holes in frame rails. If not, enlarge the holes with a die grinder or rotary tool until hardware can pass through.
5. Fishwire 7/16-14 x 1 1/2 carriage bolts and CM-SP11 spacers through access holes and out mounting holes in both frame rails, as shown. (See FISHWIRE TECHNIQUE diagram.)
6. Insert 3/8" U-bolt through tow hook as shown.
7. Raise hitch into position and secure it with 7/16-14 hex flange nuts on to carriage bolts and 3/8-16 hex flange nuts on to U-bolt, as shown. If under bodypanel is present you will need to raise it with the hitch.
8. Torque all 7/16" hardware to 50 lb-ft and 3/8" hardware to 30 lb-ft. **Note:** If underbody panel is present you will need to reach underneath it to torque the driver side bolt.
9. Trim heat shield(s) around hitch. Reinstall heat shields with hardware removed in Step 2. (See HEAT SHIELD TRIMMING DIAGRAM.)
10. Raise exhaust and reattach rubber isolators removed in Step 1. If underbody panel is present, resecure using fasteners removed in Step 3.

PERIODICALLY CHECK THIS RECEIVER HITCH TO ENSURE THAT ALL FASTENERS ARE TIGHT AND THAT ALL STRUCTURAL COMPONENTS ARE SOUND.

Curt Manufacturing Inc., warrants this product to be free of defects in material and/or workmanship at the time of retail purchase by the original purchaser. If the product is found to be defective, Curt Manufacturing Inc., may repair or replace the product, at their option, when the product is returned, prepaid, with proof of purchase. Alteration to, misuse of, or improper installation of this product voids the warranty. Curt Manufacturing Inc.'s liability is limited to repair or replacement of products found to be defective, and specifically excludes liability for incidental or consequential loss or damage.