

11184

BMW 128i COUPE, 128i CONVERTIBLE, 135i COUPE, 135i CONVERTIBLE

1/21/2011

GROSS LOAD CAPACITY WHEN USED AS A WEIGHT CARRYING HITCH: 2,000 LBS. TRAILER WEIGHT & 200 LBS. TONGUE WEIGHT.

*****DO NOT EXCEED VEHICLE MANUFACTURER'S RECOMMENDED TOWING CAPACITY.*****

WARNING: ALL NON-TRAILER LOADS APPLIED TO THIS PRODUCT MUST BE SUPPORTED BY AUXILIARY STABILIZING STRAPS.

**** FAILURE TO PROPERLY SUPPORT NON-TRAILER LOADS WILL VOID PRODUCT WARRANTY****

HAVING INSTALLATION QUESTIONS? CALL TECHNICAL SUPPORT AT 1-800-798-0813

Parts List			
ITEM	QTY	PART NUMBER	DESCRIPTION
1	4	M12 - 1.5 HEX NUT	HEX NUT
2	4	1/2"	LOCK WASHER

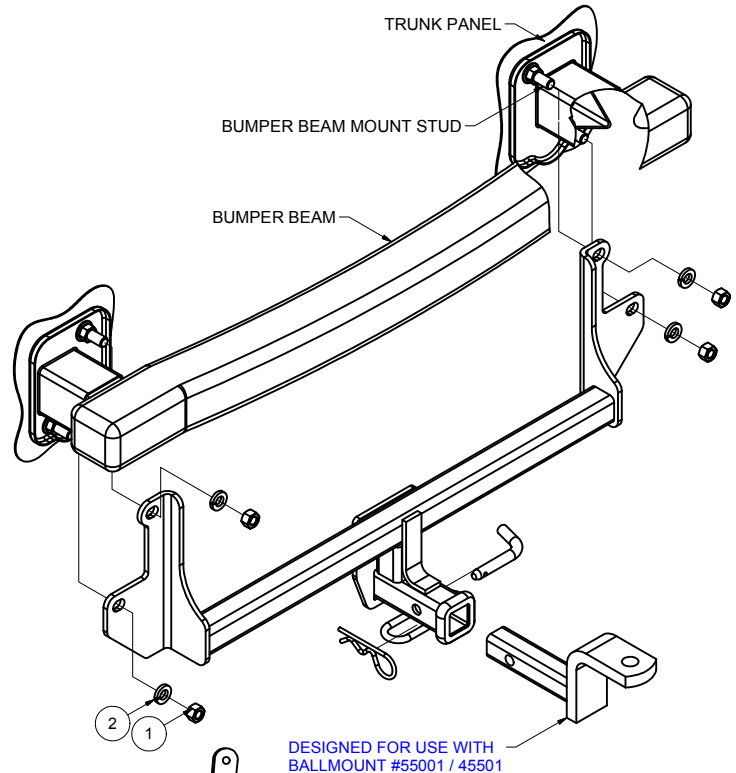
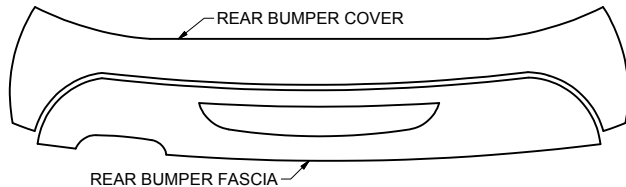

TOOLS REQUIRED	
8, 10 AND 19mm SOCKETS	
12" EXTENSION	
RATCHET	
19mm WRENCH	
FLAT BLADE SCREWDRIVER	
ROTARY TOOL W/ CUT-OFF WHEEL	
TORQUE WRENCH	

HITCH WEIGHT: 20 LBS.

INSTALL TIME

PROFESSIONAL: 60 MINUTES

NOVICE (DIY): 120 MINUTES

INSTALL NOTES:

- NO DRILLING REQUIRED
- REMOVE LOWER FASCIA AND UNDERBODY PANELS
- LOWER EXHAUST

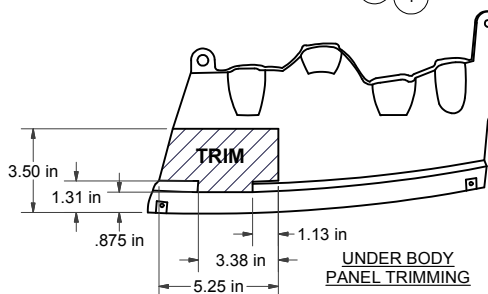

INSTALLATION STEPS

1. Remove the (2) under body panels at the rear of the vehicle.
2. Lower the exhaust by removing the 10mm bolt from the hanger bracket at the rear most mounting point.
3. Remove the rear bumper fascia by using a screw driver to release the (8) bumper fascia tabs. Remove the (4) screws securing it using an 8mm socket.
4. Raise the hitch into position over the (4) bumper beam mount studs between the trunk panel and the bumper beam, as shown. Secure the hitch using a 12mm hex nut and a 1/2" lock washer on each stud.
NOTE: Do not sandwich hitch between bumper beam and vehicle frame.(See photo "SIDE PLATE INSTALLED" above)
5. Torque all 12mm hardware to 62 lb ft.
6. Trim the under body panel to clear hitch as shown in Under Body Panel Trimming.
7. Raise the exhaust back into position and install the 10mm exhaust hanger bolt. Reinstall the rear bumper fascia and the (2) under body panels.

PERIODICALLY CHECK THIS RECEIVER HITCH TO ENSURE THAT ALL FASTENERS ARE TIGHT AND THAT ALL STRUCTURAL COMPONENTS ARE SOUND.

Curt Manufacturing Inc., warrants this product to be free of defects in material and/or workmanship at the time of retail purchase by the original purchaser. If the product is found to be defective, Curt Manufacturing Inc., may repair or replace the product, at their option, when the product is returned, prepaid, with proof of purchase. Alteration to, misuse of, or improper installation of this product voids the warranty. Curt Manufacturing Inc.'s liability is limited to repair or replacement of products found to be defective, and specifically excludes liability for incidental or consequential loss or damage.