



Safety glasses should be worn at all times while installing this product.

YEARS: 2012-CURRENT

MAKE: NISSAN

MODEL: VERSA

STYLE: SEDAN

**WARNING: NEVER EXCEED YOUR VEHICLE MANUFACTURER'S RECOMMENDED TOWING CAPACITY**

**WEIGHT CARRYING:**  
 TRAILER WEIGHT: 2,000 LBS.  
 TONGUE WEIGHT: 200 LBS.

**WARNING:**  
 WE RECOMMEND THE USE OF 18050 STABILIZING STRAPS FOR ALL NON-TRAILER (WHEEL-LESS) LOADS. PLEASE SEE THE CURT CATALOG OR VISIT US ONLINE AT [WWW.CURTMFG.COM](http://WWW.CURTMFG.COM) FOR FURTHER INFORMATION.

**INSTALLATION TIME: 30 MIN.**

THE INSTALL TIME LISTED IS FOR PROFESSIONAL INSTALLERS. IF YOU ARE HESITANT TO UNDERTAKE THIS TASK ON YOUR OWN, CONTACT AN AUTHORIZED CURT INSTALLER FOR ADDITIONAL ASSISTANCE.

**INSTALLATION REQUIRES:**

RATCHET	TORQUE WRENCH	3/4" SOCKET
10" SOCKET EXTENSION	AVIATION SHEARS	DIE GRINDER
SAFETY GLASSES		

**INSTALLATION TIPS:**

- BEFORE YOU BEGIN INSTALLATION, READ ALL INSTRUCTIONS THOROUGHLY.
- TO EASE INSTALLATION, 2 PEOPLE MAY BE REQUIRED.
- USING PROPER TOOLS WILL GREATLY IMPROVE THE QUALITY OF THE INSTALL AND REDUCE THE TIME REQUIRED.
- NEED HELP OR HAVE SOME QUESTIONS? CALL TECHNICAL SUPPORT AT 800.798.0813

**LEVEL OF DIFFICULTY: MODERATE**

EASY	MODERATE	CHALLENGING
	LOWER EXHAUST	
	ENLARGE EXISTING HOLES	
	REMOVE EXISTING HOLE PLUG	
	TRIM HEAT SHIELD	
	REVERSE FISHWIRE HARDWARE	

**VEHICLE PHOTO:**



REPRESENTATIVE PHOTO

**HITCH ILLUSTRATION:**

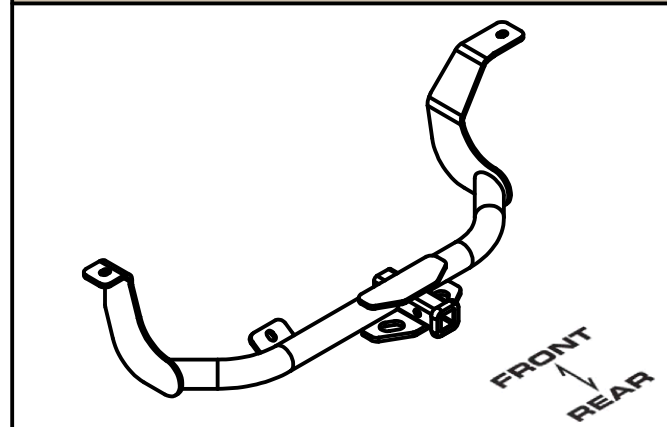

MAKE SURE YOUR HITCH MATCHES

**PERIODICALLY CHECK THIS RECEIVER HITCH TO ENSURE ALL FASTENERS ARE TIGHT AND ALL STRUCTURAL COMPONENTS ARE SOUND**

CURT Manufacturing LLC. warrants this product to be free of defects in material and/or workmanship at the time of retail purchase by the original purchaser. If the product is found to be defective, Curt Manufacturing LLC. may repair or replace the product at their option, when the product is returned, prepaid, with proof of purchase. Alteration to, misuse of, or improper installation of this product voids the warranty. Curt Manufacturing LLC.'s liability is limited to repair or replacement of products found to be defective, and specifically excludes liability for incidental or consequential loss or damage.

For more information log onto [www.curtmfg.com](http://www.curtmfg.com), & for helpful towing tips log onto [www.hitchinfo.com](http://www.hitchinfo.com)

## INSTALLATION WALKTHROUGH:

Parts List			
ITEM	QTY	PART NUMBER	DESCRIPTION
1	2	CM-SP17	.250 x 1.25 x 2.50" SQUARE HOLE SPACER
2	2	1_2 FISHWIRE	1/2" FISHWIRE
3	1	1/2-13 x 1 3/4	CARRIAGE BOLT
4	1	CM-SP4	.250 x 1.50 x 3.00" SQUARE HOLE SPACER
5	3	HFN 1213	HEX FLANGE NUT
6	2	1/2-13 x 1 1/2	CARRIAGE BOLT

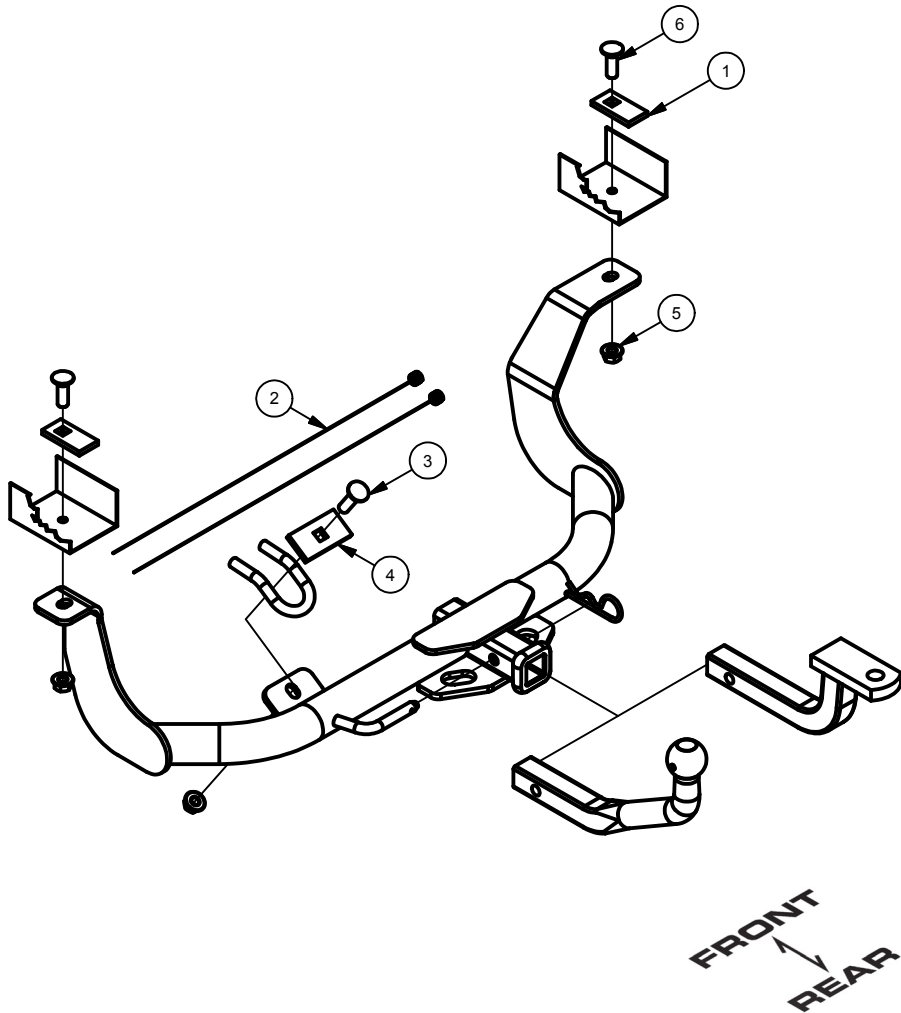

1. Lower exhaust by removing (2) exhaust isolators. Remove rubber plug from hole on driver side of vehicle.



2. Trim heat shield to allow access to round hole on passenger side of vehicle.



## INSTALLATION WALKTHROUGH:

3. Enlarge hole on driver and passenger side of vehicle to allow CM-SP17 spacer to pass into the vehicle frame rail.

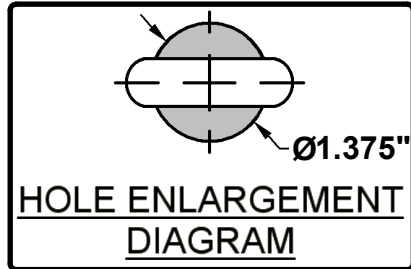

4. Reverse fishwire 1/2" x 1 1/2" carriage bolts and CM-SP17 spacers into holes enlarged in Step 3. Install 1/2" x 1 3/4" carriage bolt and CM-SP4 spacer through top of vehicle tow loop.



5. Raise hitch into position and secure with 1/2" hex flange nuts. Torque 1/2" hardware to 75 lb-ft.



6. Raise exhaust back into position and reattach the rubber isolators. Install is complete.

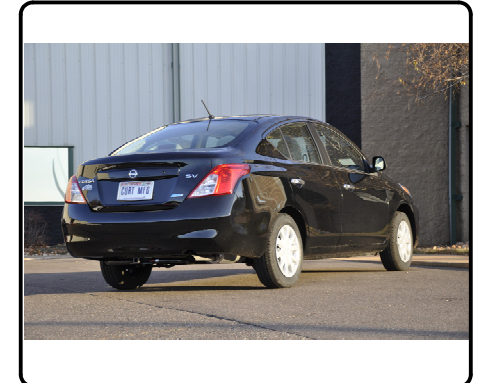

11256

# NISSAN VERSA SEDAN

11/22/2011

PAGE 1 of 2

GROSS LOAD CAPACITY WHEN USED AS A WEIGHT CARRYING HITCH: 2,000 LBS. TRAILER WEIGHT & 200 LBS. TONGUE WEIGHT.

**\*\*\*DO NOT EXCEED VEHICLE MANUFACTURER'S RECOMMENDED TOWING CAPACITY.\*\*\***

WARNING: ALL NON-TRAILER LOADS APPLIED TO THIS PRODUCT MUST BE SUPPORTED BY 18050 STABILIZING STRAPS.

**\*\* FAILURE TO PROPERLY SUPPORT NON-TRAILER LOADS WILL VOID PRODUCT WARRANTY\*\***

HAVING INSTALLATION QUESTIONS? CALL TECHNICAL SUPPORT AT 1-800-798-0813

Parts List			
ITEM	QTY	PART NUMBER	DESCRIPTION
1	2	CM-SP17	.250 x 1.25 x 2.50" SQUARE HOLE SPACER
2	2	1_2 FISHWIRE	1/2" FISHWIRE
3	1	1/2-13 x 1 3/4	CARRIAGE BOLT
4	1	CM-SP4	.250 x 1.50 x 3.00" SQUARE HOLE SPACER
5	3	HFN 1213	HEX FLANGE NUT
6	2	1/2-13 x 1 1/2	CARRIAGE BOLT

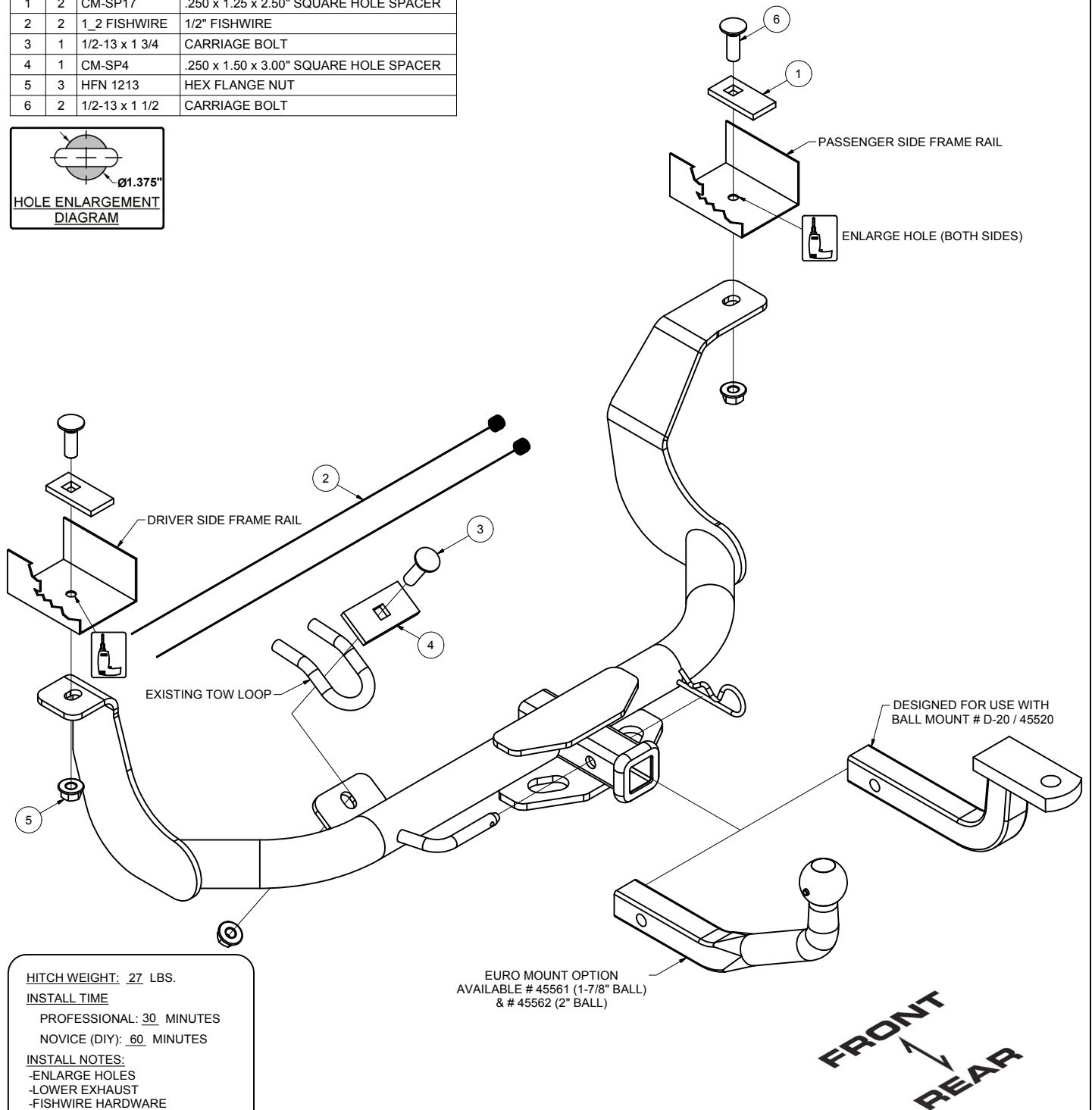
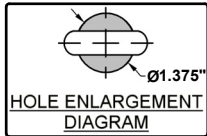

**HITCH WEIGHT:** 27 LBS.  
**INSTALL TIME**  
 PROFESSIONAL: 30 MINUTES  
 NOVICE (DIY): 60 MINUTES  
**INSTALL NOTES:**  
 -ENLARGE HOLES  
 -LOWER EXHAUST  
 -FISHWIRE HARDWARE  
 -TRIM HEAT SHIELD

EURO MOUNT OPTION  
 AVAILABLE # 45561 (1-7/8" BALL)  
 & # 45562 (2" BALL)

**PERIODICALLY CHECK THIS RECEIVER HITCH TO ENSURE THAT ALL FASTENERS ARE TIGHT AND THAT ALL STRUCTURAL COMPONENTS ARE SOUND.**

Curt Manufacturing LLC., warrants this product to be free of defects in material and/or workmanship at the time of retail purchase by the original purchaser. If the product is found to be defective, Curt Manufacturing LLC., may repair or replace the product, at their option, when the product is returned, prepaid, with proof of purchase. Alteration to, misuse of, or improper installation of this product voids the warranty. Curt Manufacturing LLC.'s liability is limited to repair or replacement of products found to be defective, and specifically excludes liability for incidental or consequential loss or damage.

HAVING INSTALLATION QUESTIONS? CALL TECHNICAL SUPPORT AT 1-800-798-0813

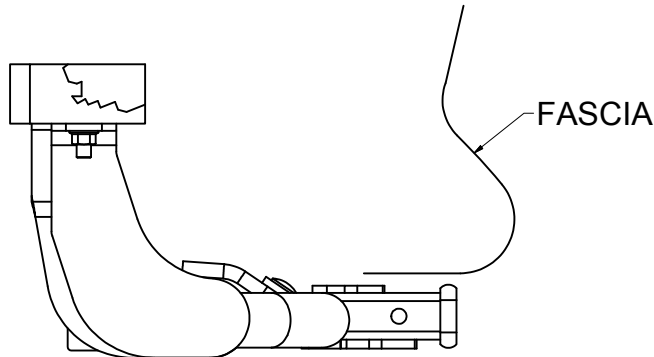

INSTALLED HITCH POSITION

**REVERSE PULL FISHWIRE  
TECHNIQUE**

ATTACH FISHWIRE TO CARRIAGE BOLT AND SLIDE SPACER ONTO FISHWIRE. PUSH THE BOLT THRU THE HOLE FOLLOWED BY THE SPACER (AS SHOWN). PULL BOLT BACK INTO POSITION, PROTRUDING FROM THE FRAME.

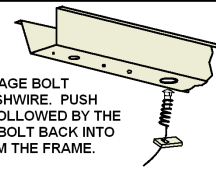

TOOLS REQUIRED
RATCHET
TORQUE WRENCH
3/4" SOCKET
10" SOCKET EXTENSION
AVIATION SHEARS
DIE GRINDER

**RUBBER ISOLATOR  
REMOVAL DIAGRAM**

This technique can be used if an Exhaust Hanger Removal Pliers is not available.

Using a 5/8" open end wrench, slide the wrench up to the rubber isolator, cradling the hanger rod as shown. Next place the flat edge of a pry bar between the wrench and the hanger stop or hanger rod. Then simply rotate the pry bar toward the wrench to remove the rubber isolator.

Note: Using a spray lubricant or soapy water on the hanger rod and the rubber isolator helps removal.

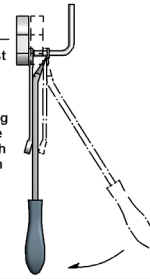

## INSTALLATION STEPS

1. Lower exhaust by removing (2) exhaust isolators. (See RUBBER ISOLATOR REMOVAL diagram)
2. Remove rubber plug from hole on driver side of vehicle.
3. Trim heat shield to allow access to round hole on passenger side of vehicle.
4. Enlarge hole on driver and passenger side of vehicle to allow CM-SP17 spacer to pass into the vehicle frame rail.
5. Reverse fishwire 1/2" x 1 1/2" carriage bolts and CM-SP17 spacers into holes enlarged in Step 4. (See REVERSE PULL FISHWIRE TECHNIQUE diagram)
6. Install 1/2" x 1 3/4" carriage bolt and CM-SP4 spacer through top of vehicle tow loop.
7. Raise hitch into position and secure with 1/2" hex flange nuts.
8. Torque 1/2" hardware to 75 lb-ft.
9. Raise exhaust back into position and reattach the rubber isolators.

**PERIODICALLY CHECK THIS RECEIVER HITCH TO ENSURE THAT ALL FASTENERS ARE TIGHT AND THAT ALL STRUCTURAL COMPONENTS ARE SOUND.**