



Safety glasses should be worn at all times while installing this product.

YEARS: 2013

MAKE: CADILLAC

MODEL: ATS

STYLE: SEDAN & COUPE

**WARNING: NEVER EXCEED YOUR VEHICLE MANUFACTURER'S RECOMMENDED TOWING CAPACITY**

**WEIGHT CARRYING:**  
 TRAILER WEIGHT: 2,000 LBS.  
 TONGUE WEIGHT: 200 LBS.

**WARNING:**  
 WE RECOMMEND THE USE OF 18050 STABILIZING STRAPS FOR ALL NON-TRAILER (WHEEL-LESS) LOADS. PLEASE SEE THE CURT CATALOG OR VISIT US ONLINE AT [WWW.CURTMFG.COM](http://WWW.CURTMFG.COM) FOR FURTHER INFORMATION.

**INSTALLATION TIME: 30/60 MIN.**  
 THE INSTALL TIME LISTED IS FOR PROFESSIONAL/NOVICE INSTALLERS. IF YOU ARE HESITANT TO UNDERTAKE THIS TASK ON YOUR OWN, CONTACT AN AUTHORIZED CURT INSTALLER FOR ADDITIONAL ASSISTANCE.

- INSTALLATION TIPS:**
- BEFORE YOU BEGIN INSTALLATION, READ ALL INSTRUCTIONS THOROUGHLY.
  - TO EASE INSTALLATION, 2 PEOPLE MAY BE REQUIRED.
  - USING PROPER TOOLS WILL GREATLY IMPROVE THE QUALITY OF THE INSTALL AND REDUCE THE TIME REQUIRED.
  - NEED HELP OR HAVE SOME QUESTIONS? CALL TECHNICAL SUPPORT AT 800.798.0813



**INSTALLATION REQUIRES:**

SAFETY GLASSES	T-15 TORXBIT SOCKET	RATCHET
SOCKET	SOCKET	PRY BAR
SPRAY LUBRICANT	CUT-OFF WHEEL	TAPE MEASURE
MARKER	AVIATION SHEARS	TORQUE WRENCH

**LEVEL OF DIFFICULTY: MODERATE**

EASY	MODERATE	CHALLENGING
	LOWER EXHAUST TO EASE INSTALLATION	
	FISHWIRING REQUIRED	
	REMOVAL OF EXHAUST SUPPORT STRAP MAY EASE INSTALLATION	
	PLASTIC AND HEAT SHIELD TRIMMING REQUIRED	
	NO DRILLING REQUIRED	

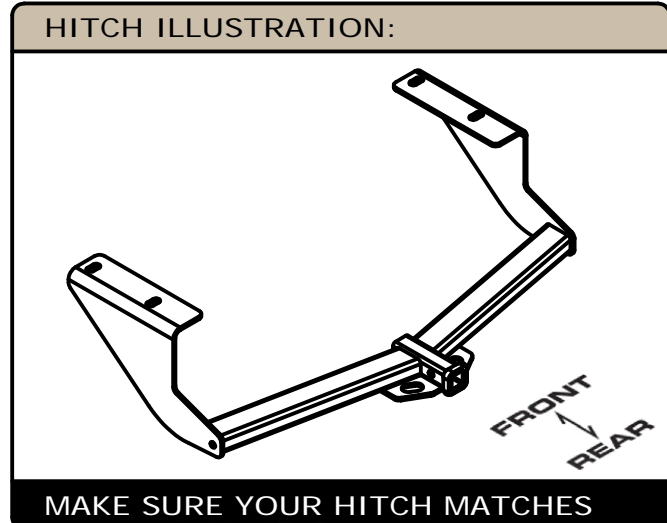

**PERIODICALLY CHECK THIS RECEIVER HITCH TO ENSURE ALL FASTENERS ARE TIGHT AND ALL STRUCTURAL COMPONENTS ARE SOUND**

CURT Manufacturing LLC. warrants this product to be free of defects in material and/or workmanship at the time of retail purchase by the original purchaser. If the product is found to be defective, Curt Manufacturing LLC. may repair or replace the product at their option, when the product is returned, prepaid, with proof of purchase. Alteration to, misuse of, or improper installation of this product voids the warranty. Curt Manufacturing LLC.'s liability is limited to repair or replacement of products found to be defective, and specifically excludes liability for incidental or consequential loss or damage.

For more information log onto [www.curtmfg.com](http://www.curtmfg.com), & for helpful towing tips log onto [www.hitchinfo.com](http://www.hitchinfo.com)

## INSTALLATION WALKTHROUGH:

Parts List			
ITEM	QTY	PART NUMBER	DESCRIPTION
1	4	1/2-13 x 1 1/2	CARRIAGE BOLT
2	4	HFN 1213	HEX FLANGE NUT
3	4	CM-SP6	.250 x 1.00 x 3.00" SPACER
4	4	1_2 x 30 FISHWIRE	1/2" x 30" FISHWIRE

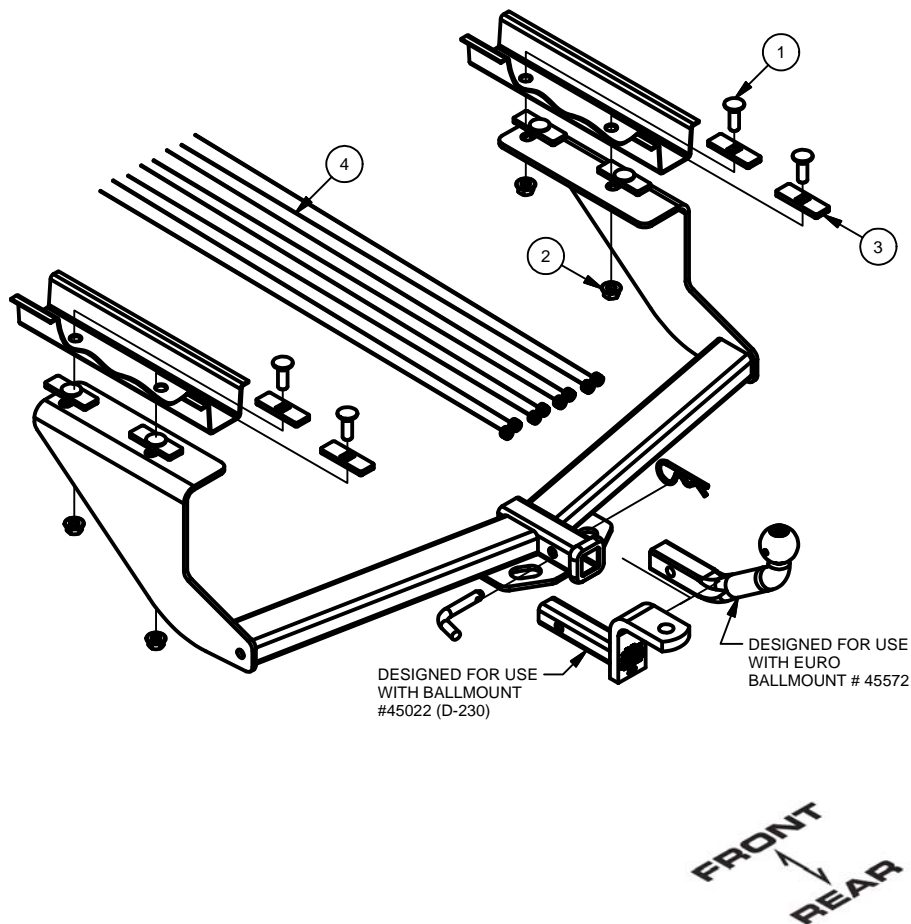

1. Remove (14) screws that secure plastic fascia to bottom of vehicle. This will allow fascia to be pulled away from exhaust, and allow heat shield to be removed.  
Coupe models: Remove fasteners with a 7mm socket.

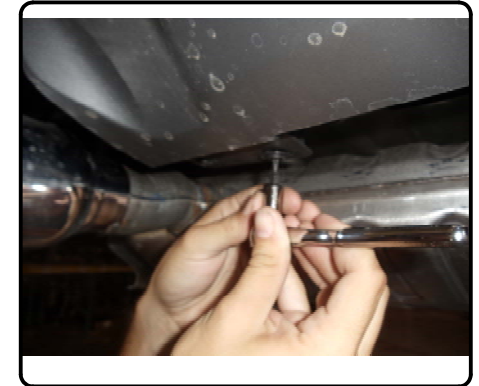

2. Lower exhaust by first removing (2) bolts on each side from the end of the vehicle frame rails that secure the exhaust hanger brackets. Remove brackets from hanger pegs on muffer. Then remove the rubber exhaust hangers, (4) places forward of mufflers (3) places on Coupe models.

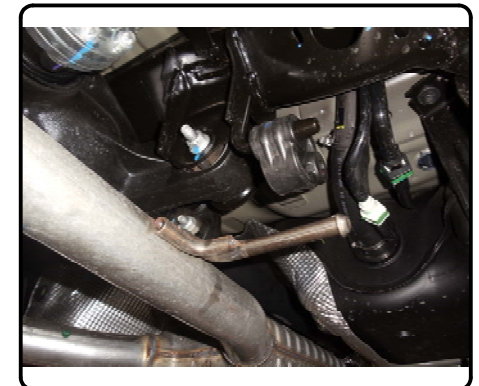
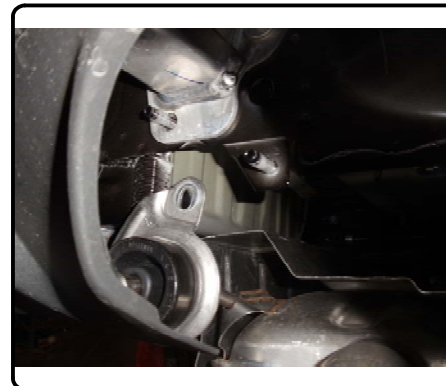

## INSTALLATION WALKTHROUGH:

3. It may be necessary to remove support strap to allow exhaust to hang lower and allow heat shield to be fully removed. It will be necessary to gently pull fascia downward to allow muffler pegs to be below fascia.



4. Remove heat shield by removing (8) nuts which secure it to the vehicle. Retain (6) nuts for reinstallation after heat shield trimming.

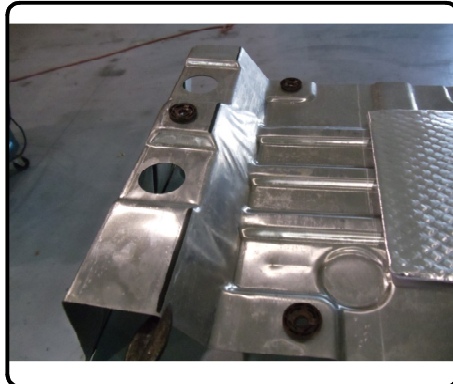
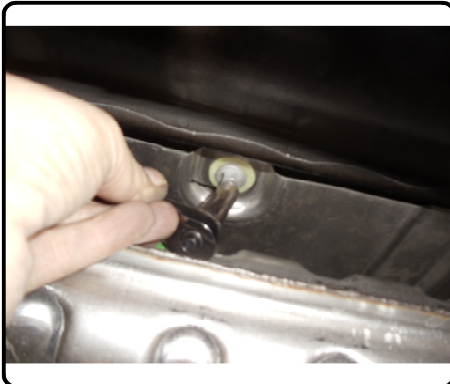

5. Cut off stud from each frame rail that secured the heat shield. Mark heat shield as shown and trim to allow access to both frame rails. Reattach trimmed heat shield using (6) nuts removed in Step 4.

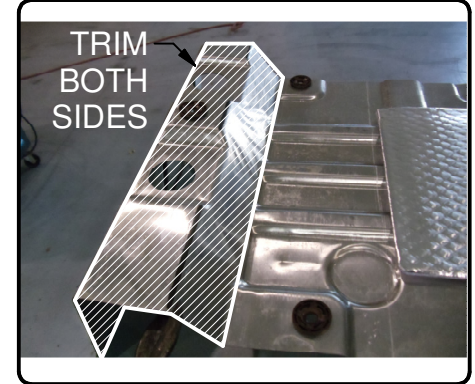
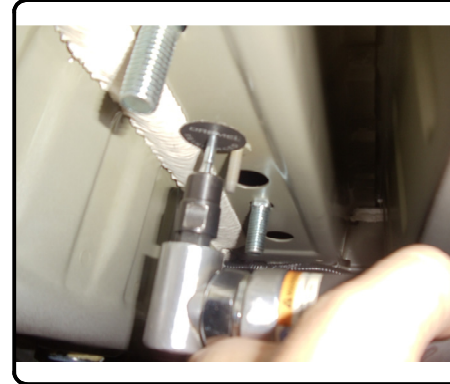

6. Trim vehicle fascia as shown on each side of the vehicle to allow for hitch side plate reinstallation, approximately 1-3/8" each side.

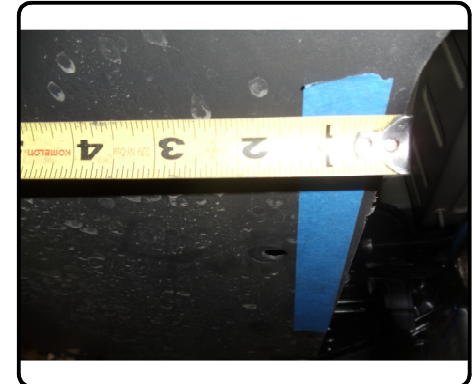

## INSTALLATION WALKTHROUGH:

7. Fishwire 1/2" carriage bolts and spacer blocks up through slots in vehicle frame and down through attaching holes in hitch side plates, 2 places, each side.



8. Raise hitch into position, being careful not to push bolts back into frame. Secure with 1/2" flange hex nuts. Torque all 1/2" hardware to 110 lb-ft.

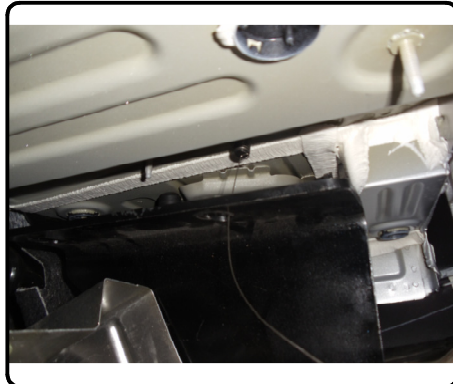

9. Raise exhaust into position by reversing all steps in Step 1. Reattach exhaust support strap if removed in Step 3.



10. Installation complete.



GROSS LOAD CAPACITY WHEN USED AS A WEIGHT CARRYING HITCH: 2,000 LBS. TRAILER WEIGHT & 200 LBS. TONGUE WEIGHT.

\*\*\*DO NOT EXCEED VEHICLE MANUFACTURER'S RECOMMENDED TOWING CAPACITY.\*\*\*

**WARNING: ALL NON-TRAILER LOADS APPLIED TO THIS PRODUCT MUST BE SUPPORTED BY 18050 STABILIZING STRAPS.**

\*\* FAILURE TO PROPERLY SUPPORT NON-TRAILER LOADS WILL VOID PRODUCT WARRANTY\*\*

HAVING INSTALLATION QUESTIONS? CALL TECHNICAL SUPPORT AT 1-800-798-0813

Parts List			
ITEM	QTY	PART NUMBER	DESCRIPTION
1	4	1/2-13 x 1 1/2	CARRIAGE BOLT
2	4	HFN 1213	HEX FLANGE NUT
3	4	CM-SP6	.250 x 1.00 x 3.00" SQUARE HOLE SPACER
4	4	1_2 x 30 FISHWIRE	1/2" x 30" FISHWIRE

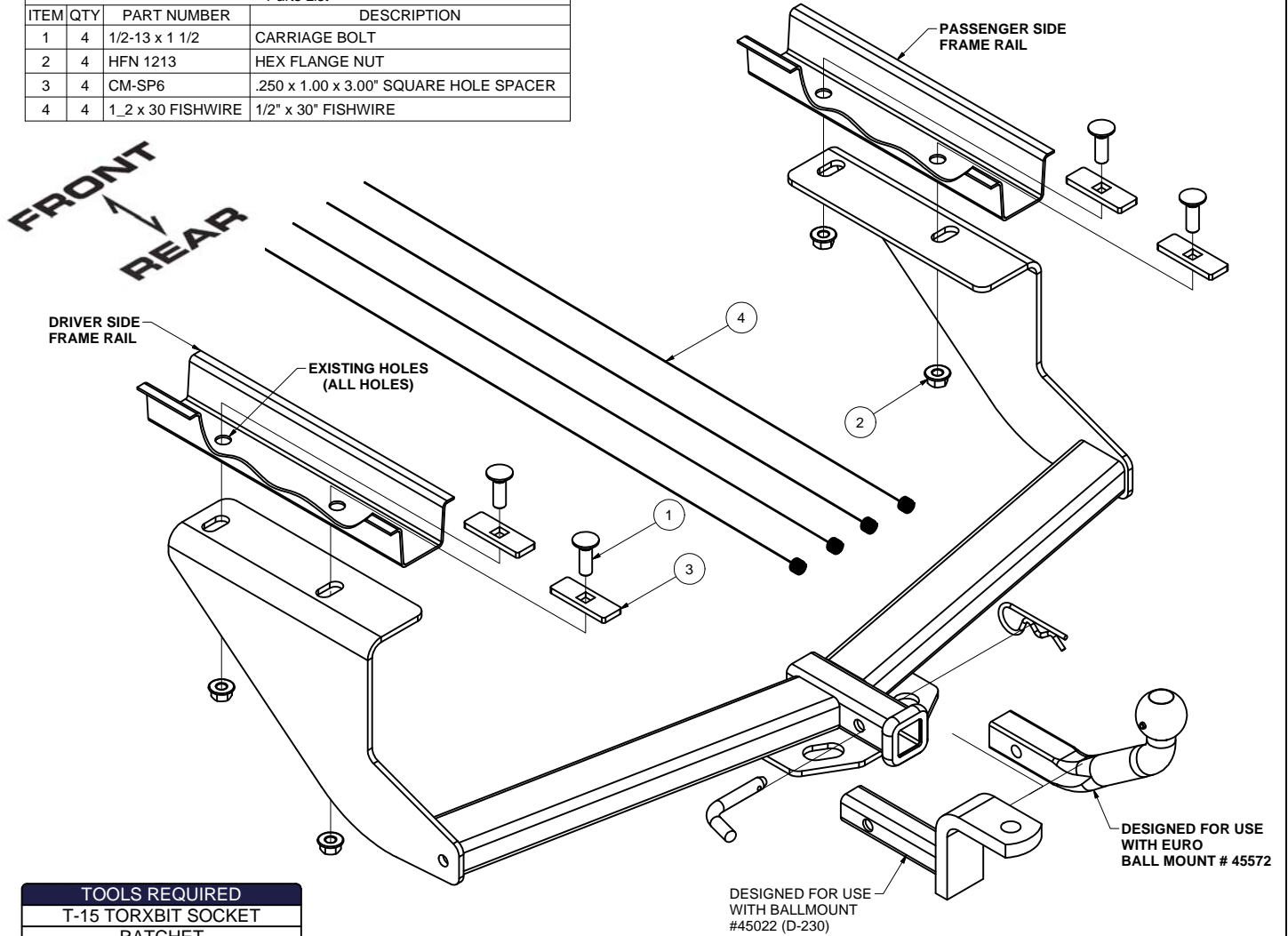

TOOLS REQUIRED
T-15 TORXBIT SOCKET
RATCHET
SOCKET SET
PRY BAR
SPRAY LUBRICANT
CUT-OFF WHEEL
TAPE MEASURE
AVIATION SHEARS
TORQUE WRENCH

**HITCH WEIGHT:** .39 LBS.  
**INSTALL TIME**  
 PROFESSIONAL: 30 MINUTES  
 NOVICE (DIY): 60 MINUTES  
**INSTALL NOTES:**  
 - FISHWIRE HARDWARE  
 - MAY REQUIRE PANEL/ HEAT SHIELD TRIMMING

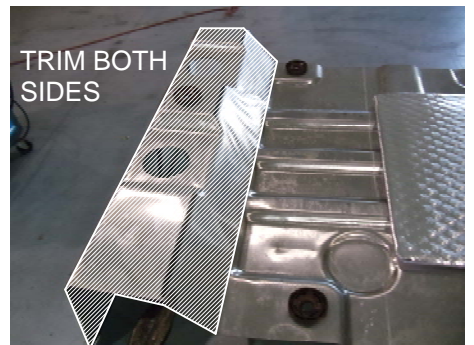
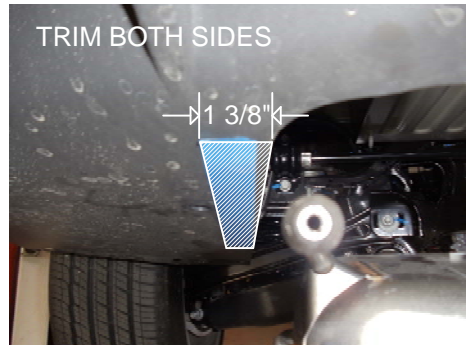

PERIODICALLY CHECK THIS RECEIVER HITCH TO ENSURE THAT ALL FASTENERS ARE TIGHT AND THAT ALL STRUCTURAL COMPONENTS ARE SOUND.

Curt Manufacturing LLC., warrants this product to be free of defects in material and/or workmanship at the time of retail purchase by the original purchaser. If the product is found to be defective, Curt Manufacturing LLC., may repair or replace the product, at their option, when the product is returned, prepaid, with proof of purchase. Alteration to, misuse of, or improper installation of this product voids the warranty. Curt Manufacturing LLC.'s liability is limited to repair or replacement of products found to be defective, and specifically excludes liability for incidental or consequential loss or damage.

**INSTALLATION STEPS**

1. Remove (14) screws that secure plastic fascia to bottom of vehicle. This will allow fascia to be pulled away from exhaust, and allow heat shield to be removed. Coupe models: remove fasteners with a 7mm socket.
2. Lower exhaust by first removing (2) bolts on each side from the end of the vehicle frame rails that secure the exhaust hanger brackets. Remove brackets from hanger pegs on muffler. Then remove the rubber exhaust hangers, (4) places forward of mufflers, (3) places on Coupe models.
3. It may be necessary to remove support strap to allow exhaust to hang lower and allow heat shield to be fully removed. It will be necessary to gently pull fascia downward to allow muffler pegs to be below fascia.
4. Remove heat shield by removing (8) nuts which secure it to the vehicle. Retain (6) nuts for reinstallation after heat shield trimming.
5. Cut off stud from each frame rail that secured the heat shield.  
  
Mark heat shield as shown and trim to allow access to both frame rails. Reattach trimmed heat shield using (6) nuts removed in Step 4.
6. Trim vehicle fascia as shown on each side of the vehicle to allow for hitch side plate reinstallation, approximately 1-3/8" each side.
7. Fishwire 1/2" carriage bolts and spacer blocks up through slots in vehicle frame and down through attaching holes in hitch side plates, 2 places, each side.
8. Raise hitch into position, being careful not to push bolts back into frame. Secure with 1/2" flange hex nuts. Torque all 1/2" hardware to 110 lb-ft.
9. Raise exhaust into position by reversing all steps in Step 1. Reattach exhaust support strap if removed in Step 3.

PERIODICALLY CHECK THIS RECEIVER HITCH TO ENSURE THAT ALL FASTENERS ARE TIGHT AND THAT ALL STRUCTURAL COMPONENTS ARE SOUND.