

11319

# FORD FOCUS S,SE,& SES COUPE & SEDAN

11/9/07

GROSS LOAD CAPACITY WHEN USED AS A WEIGHT CARRYING HITCH: 2,000 LBS. TRAILER WEIGHT & 200 LBS. TONGUE WEIGHT.  
 \*\*\*DO NOT EXCEED VEHICLE MANUFACTURER'S RECOMMENDED TOWING CAPACITY.\*\*\*

Parts List				
ITEM	QTY	PART NUMBER	DESCRIPTION	
1	1	1_2 FISHWIRE	1/2" FISHWIRE	
2	2	3/8-16 X 1 1/2	HEX BOLT	
3	2	HFN3816	HEX FLANGE NUT	
4	2	3/8"	WASHER	
5	2	7/16-14	HEX FLANGE NUT	
6	2	7/16-14 x 1 1/2	HEX BOLT	
7	2	7/16	WASHER	
8	2	HFN 1213	HEX FLANGE NUT	
9	2	1/2-13 x 1 1/2	CARRIAGE BOLT	
10	2	CM-SP6	.250 x 1.00 x 3.00" SQUARE HOLE SPACER	
11	1	CM-11319-PSB	.375" PASSENGER SIDE BRACKET	
12	1	CM-11319-DSB	.375" DRIVER SIDE BRACKET	

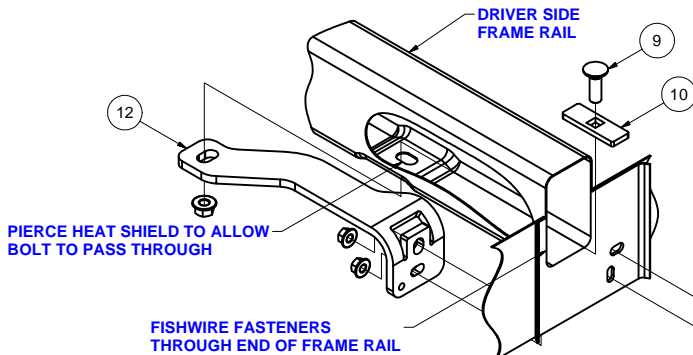
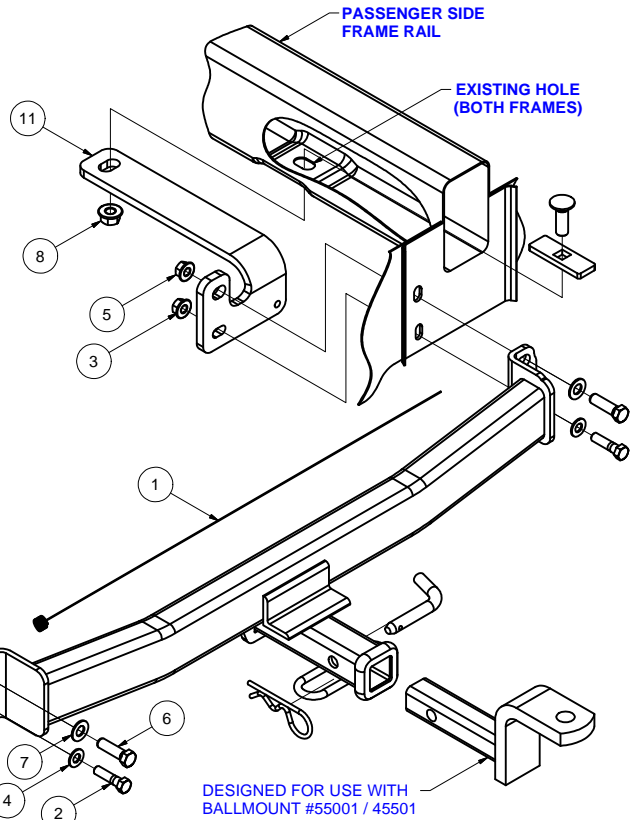

### TOOLS REQUIRED

PHILLIPS HEAD SCREW DRIVER
3/8" DRIVE RATCHET
3/8" DRIVE TORQUE WRENCH
3/4" - 3/8" DRIVE SHORT SOCKET
11/16" - 3/8" DRIVE SOCKET
9/16" - 3/8" DRIVE SOCKET
5/8" BOXED END WRENCH
9/16" BOXED END WRENCH

HITCH WEIGHT: 27 LBS.

INSTALL TIME: 40 MINUTES

#### INSTALL NOTES:

- LOWER EXHAUST
- FISHWIRING REQUIRED
- MODIFY HEAT SHIELD

## INSTALLATION STEPS

- 1) Lower exhaust from vehicle by unhooking the 3 rear rubber hangers.
- 2) Locate the hole existing on the driver side frame rail. Using a screwdriver or pointed tool, pierce the heat shield just below the hole in the frame rail. (Enlarge to approximately 1/2")
- 3) Fishwire the 1/2" carriage bolts and spacers through the end of the frame and into position as shown.
- 4) Install the passenger and driver side brackets over fishwired bolts, install flange nuts finger tight.
- 5) Raise hitch into position and aligning the brackets and vehicle flange holes with the hitch. Install the remaining fasteners.
- 6) Torque all 1/2" fasteners 75 lb-ft, all 7/16" fasteners to 50 lb-ft, and all 3/8" fasteners to 30 lb-ft.
- 7) Raise exhaust and re-install rubber hangers.

PERIODICALLY CHECK THIS RECEIVER HITCH TO ENSURE THAT ALL FASTENERS ARE TIGHT AND THAT ALL STRUCTURAL COMPONENTS ARE SOUND.

Curt Manufacturing Inc., warrants this product to be free of defects in material and/or workmanship at the time of retail purchase by the original purchaser. If the product is found to be defective, Curt Manufacturing Inc., may repair or replace the product, at their option, when the product is returned, prepaid, with proof of purchase. Alteration to, misuse of, or improper installation of this product voids the warranty. Curt Manufacturing Inc.'s liability is limited to repair or replacement of products found to be defective, and specifically excludes liability for incidental or consequential loss or damage.