



Safety glasses should be worn at all times while installing this product.

**YEARS:** 2013-PRESENT

**MAKE:** CHEVROLET

**MODEL:** SPARK (LS & 1LT MODELS W/ STANDARD REAR FASCIA)

**STYLE:** HATCHBACK

**WARNING: NEVER EXCEED YOUR VEHICLE MANUFACTURER'S RECOMMENDED TOWING CAPACITY**

**WEIGHT CARRYING:**  
**TRAILER WEIGHT:** 2,000 LBS.  
**TONGUE WEIGHT:** 200 LBS.

**WARNING:**  
 WE RECOMMEND THE USE OF 18050 STABILIZING STRAPS FOR ALL NON-TRAILER (WHEEL-LESS) LOADS. PLEASE SEE THE CURT CATALOG OR VISIT US ONLINE AT [WWW.CURTMFG.COM](http://WWW.CURTMFG.COM) FOR FURTHER INFORMATION.

**INSTALLATION TIME: 20/45 MIN.**  
 THE INSTALL TIME LISTED IS FOR PROFESSIONAL/NOVICE INSTALLERS. IF YOU ARE HESITANT TO UNDERTAKE THIS TASK ON YOUR OWN, CONTACT AN AUTHORIZED CURT INSTALLER FOR ADDITIONAL ASSISTANCE.

- INSTALLATION TIPS:**
- BEFORE YOU BEGIN INSTALLATION, READ ALL INSTRUCTIONS THOROUGHLY.
  - TO EASE INSTALLATION, 2 PEOPLE MAY BE REQUIRED.
  - USING PROPER TOOLS WILL GREATLY IMPROVE THE QUALITY OF THE INSTALL AND REDUCE THE TIME REQUIRED.
  - NEED HELP OR HAVE SOME QUESTIONS? CALL TECHNICAL SUPPORT AT 800.798.0813



**INSTALLATION REQUIRES:**

<b>DIE GRINDER</b>	<b>PRY BAR</b>	<b>RATCHET</b>
<b>SAFETY GLASSES</b>	<b>SPRAY LUBRICANT</b>	<b>SOCKET 11/16 3/4</b>
<b>TORQUE WRENCH</b>		

**LEVEL OF DIFFICULTY: MODERATE**

<i>EASY</i>	<i>MODERATE</i>	<i>CHALLENGING</i>
	REVERSE FISHWIRE HARDWARE	
	TEMPORARILY LOWER EXHAUST	
	HOLE ENLARGEMENT REQUIRED	

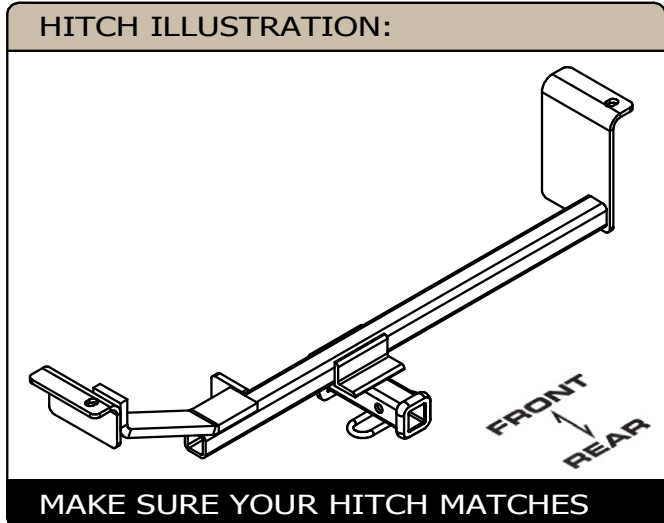

**PERIODICALLY CHECK THIS RECEIVER HITCH TO ENSURE ALL FASTENERS ARE TIGHT AND ALL STRUCTURAL COMPONENTS ARE SOUND**

CURT Manufacturing LLC. warrants this product to be free of defects in material and/or workmanship at the time of retail purchase by the original purchaser. If the product is found to be defective, Curt Manufacturing LLC. may repair or replace the product at their option, when the product is returned, prepaid, with proof of purchase. Alteration to, misuse of, or improper installation of this product voids the warranty. Curt Manufacturing LLC.'s liability is limited to repair or replacement of products found to be defective, and specifically excludes liability for incidental or consequential loss or damage.

For more information log onto [www.curtmfg.com](http://www.curtmfg.com), & for helpful towing tips log onto [www.hitchinfo.com](http://www.hitchinfo.com)

## INSTALLATION WALKTHROUGH:

Parts List			
ITEM	QTY	PART NUMBER	DESCRIPTION
1	2	7/16 - 14 x 1 3/4	CARRIAGE BOLT
2	2	CM-SP2	.250 x .88 x 2.25" SPACER
3	2	7/16-14	HEX FLANGE NUT
4	2	7_16 FISHWIRE	7/16" FISHWIRE
5	1	1/2-13 x 1 3/4	CARRIAGE BOLT
6	1	CM-SP26	.250 x 1.50 x 2.25" SPACER
7	1	HFN 1213	HEX FLANGE NUT

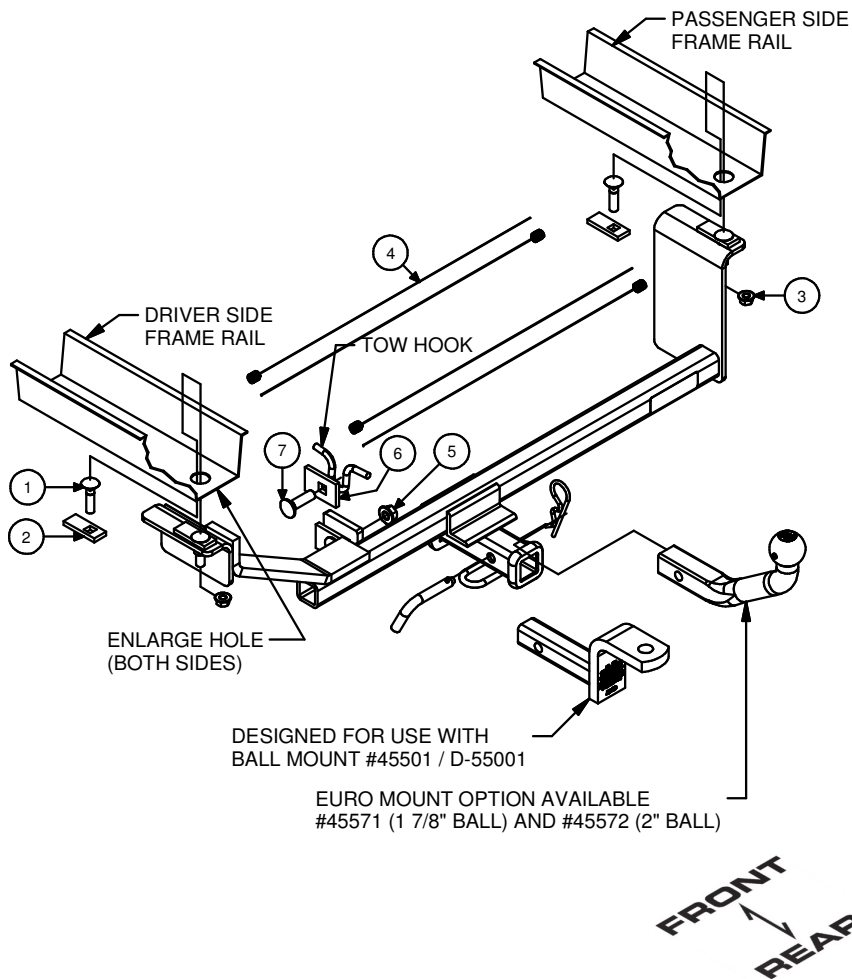

1. Lower exhaust by disconnecting exhaust hangers from rubber isolators, one forward and one rearward of muffler.



2. Enlarge hole at the end of each frame rail to accommodate square hole spacers and 7/16" carriage bolts.



## INSTALLATION WALKTHROUGH:

3. Reverse fishwire square hole spacers and 7/16" carriage bolts up through hole enlarged in Step 2 and back down through same hole.

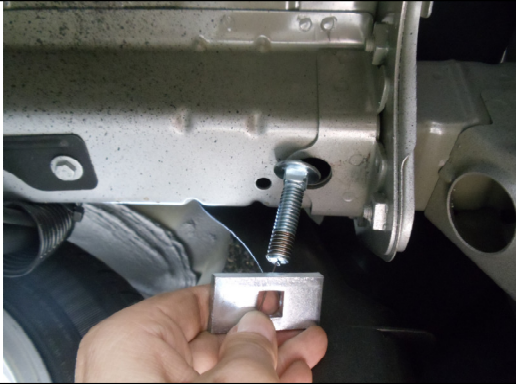

5. Install 1/2" carriage bolt with large square hole spacer through tow hook and support bar on hitch and fasten with 1/2" flange nut, as shown.



4. Raise hitch into position and loosely attach 7/16" hex flange nuts to carriage bolts.



6. Torque 7/16" hardware to 70 lb-ft.  
Torque 1/2" hardware to 110 lb-ft.

Installation is complete



**11334****CHEVROLET SPARK (LS & 1LT MODELS W/ STANDARD REAR FASCIA)****1/23/2013****GROSS LOAD CAPACITY WHEN USED AS A WEIGHT CARRYING HITCH: 2,000 LBS. TRAILER WEIGHT & 200 LBS. TONGUE WEIGHT.****\*\*\*DO NOT EXCEED VEHICLE MANUFACTURER'S RECOMMENDED TOWING CAPACITY.\*\*\*****WARNING: ALL NON-TRAILER LOADS APPLIED TO THIS PRODUCT MUST BE SUPPORTED BY 18050 STABILIZING STRAPS.****\*\* FAILURE TO PROPERLY SUPPORT NON-TRAILER LOADS WILL VOID PRODUCT WARRANTY\*\*****HAVING INSTALLATION QUESTIONS? CALL TECHNICAL SUPPORT AT 1-800-798-0813**

Parts List			
ITEM	QTY	PART NUMBER	DESCRIPTION
1	2	7/16 - 14 x 1 3/4	CARRIAGE BOLT
2	2	CM-SP2	.250 x .88 x 2.25" SPACER
3	2	7/16-14	HEX FLANGE NUT
4	2	7_16 FISHWIRE	7/16" FISHWIRE
5	1	1/2-13 x 1 3/4	CARRIAGE BOLT
6	1	CM-SP26	.250 x 1.50 x 2.25" SPACER
7	1	HFN 1213	HEX FLANGE NUT

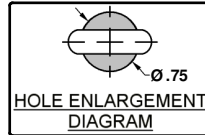
**REVERSE PULL FISHWIRE TECHNIQUE**

ATTACH FISHWIRE TO CARRIAGE BOLT AND SLIDE SPACER ONTO FISHWIRE. PUSH THE BOLT THRU THE HOLE FOLLOWED BY THE SPACER (AS SHOWN). PULL BOLT BACK INTO POSITION, PROTRUDING FROM THE FRAME.

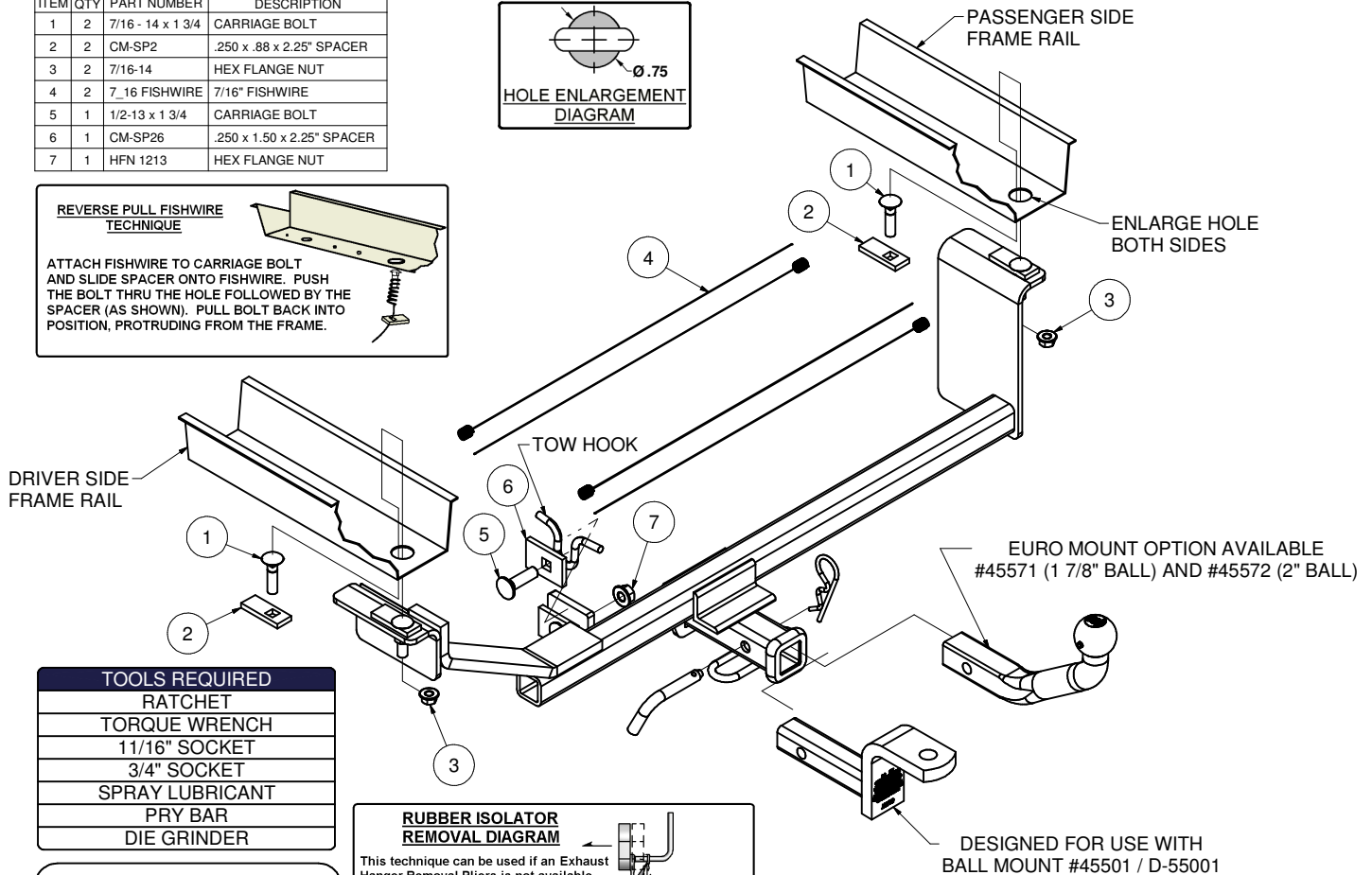
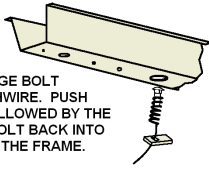
**TOOLS REQUIRED**

RATCHET  
TORQUE WRENCH  
11/16" SOCKET  
3/4" SOCKET  
SPRAY LUBRICANT  
PRY BAR  
DIE GRINDER

**RUBBER ISOLATOR REMOVAL DIAGRAM**

This technique can be used if an Exhaust Hanger Removal Pliers is not available.

Using a 5/8" open end wrench, slide the wrench up to the rubber isolator, cradling the hanger rod as shown. Next place the flat edge of a pry bar between the wrench and the hanger stop or hanger rod. Then simply rotate the pry bar toward the wrench to remove the rubber isolator.

Note: Using a spray lubricant or soapy water on the hanger rod and the rubber isolator helps removal.

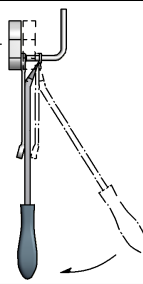
**HITCH WEIGHT: 20 LBS.****INSTALL TIME**

PROFESSIONAL: 20 MINUTES

NOVICE (DIY): 45 MINUTES

**INSTALL NOTES:**

- NO DRILLING REQUIRED
- REVERSE FISHWIRE HARDWARE
- LOWER EXHAUST
- HOLE ENLARGEMENT REQUIRED

**INSTALLATION STEPS**

1. Lower exhaust by disconnecting exhaust hangers from rubber isolators, one forward and one rearward of muffler.
2. Enlarge hole at the end of each frame rail to accommodate square hole spacers and 7/16" carriage bolts.
3. Reverse fishwire square hole spacers and 7/16" carriage bolts up through hole enlarged in Step 2 and back down through same hole.
4. Raise hitch into position and loosely attach 7/16" hex flange nuts to carriage bolts.
5. Install 1/2" carriage bolt with large square hole spacer through tow hook and support bar on hitch and fasten with 1/2" hex flange nut, as shown.
6. Torque 7/16" hardware to 70 lb.-ft. Torque 1/2" hardware to 110 lb.-ft.
7. Raise exhaust back into position.

**PERIODICALLY CHECK THIS RECEIVER HITCH TO ENSURE THAT ALL FASTENERS ARE TIGHT AND THAT ALL STRUCTURAL COMPONENTS ARE SOUND.**

Curt Manufacturing LLC., warrants this product to be free of defects in material and/or workmanship at the time of retail purchase by the original purchaser. If the product is found to be defective, Curt Manufacturing LLC., may repair or replace the product, at their option, when the product is returned, prepaid, with proof of purchase. Alteration, to misuse of, or improper installation of this product voids the warranty. Curt Manufacturing LLC.'s liability is limited to repair or replacement of products found to be defective, and specifically excludes liability for incidental or consequential loss or damage.