

11348

NISSAN VERSA (HATCH BACK AND SEDAN)

9/02/2009

GROSS LOAD CAPACITY WHEN USED AS A WEIGHT CARRYING HITCH: 2,000 LBS. TRAILER WEIGHT & 200 LBS. TONGUE WEIGHT.

DO NOT EXCEED VEHICLE MANUFACTURER'S RECOMMENDED TOWING CAPACITY.

WARNING: ALL NON-TRAILER LOADS APPLIED TO THIS PRODUCT MUST BE SUPPORTED BY AUXILIARY STABILIZING STRAPS.

** FAILURE TO PROPERLY SUPPORT NON-TRAILER LOADS WILL VOID PRODUCT WARRANTY**

HAVING INSTALLATION QUESTIONS? CALL TECHNICAL SUPPORT AT 1-800-798-0813

		Parts List	
ITEM	QTY	PART NUMBER	DESCRIPTION
1	2	1/2"	WASHER
2	2	1/2-13 x 1 3/4	CARRIAGE BOLT
3	2	1/2"	FISHWIRE TOOL
4	3	HFN 1213	HEX FLANGE NUT
5	3	CM-SP6	.250 x 1.00 x 3.00" SQUARE HOLE SPACER
6	1	CM-SP12	.250 x 1.00 x 2.00" SQUARE HOLE SPACER
7	1	1/2 - 13 x 2"	CARRIAGE BOLT

FISHWIRE TECHNIQUE

INSERT COILED END OF FISHWIRE TOOL THROUGH HITCH MOUNTING HOLE IN VEHICLE FRAME RAIL AND OUT THE ACCESS HOLE. PASS COILED END OF FISHWIRE THROUGH SPACER AND THREAD BOLT INTO COIL. KINK WIRE TO KEEP SPACER SEPERATE FROM BOLT AS SHOWN. PULL FISHWIRE, SPACER, AND BOLT THROUGH FRAME AND OUT MOUNTING HOLE. USE FISHWIRE TO GUIDE HITCH DURING MOUNTING AND PREVENT LOSS OF BOLT / SPACER INSIDE FRAME RAIL.

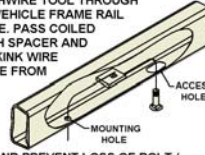

***NOTE: SOME VEHICLES MAY FISHWIRE THROUGH END OF FRAME**

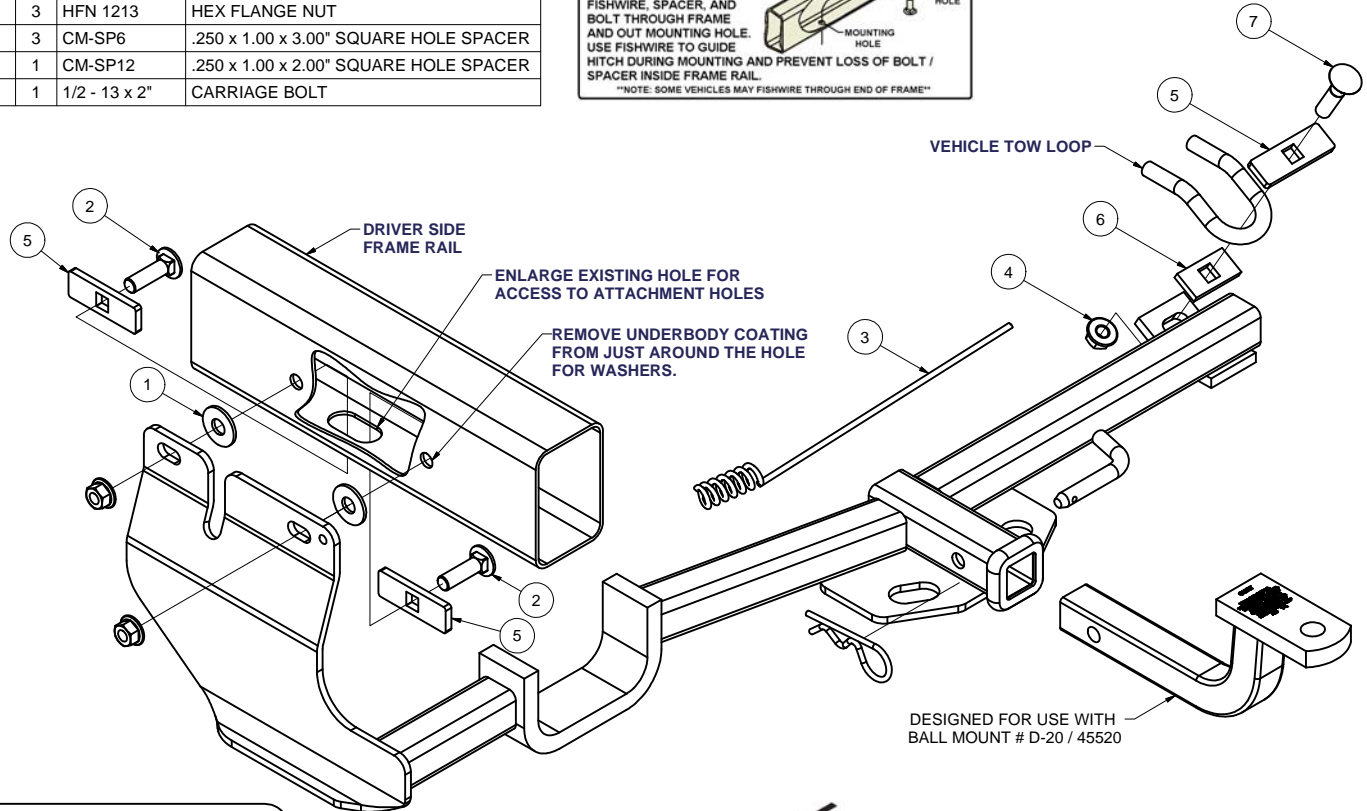

HITCH WEIGHT: 29 LBS.

INSTALL TIME

PROFESSIONAL: 30 MINUTES

NOVICE (DIY): 60 MINUTES

INSTALL NOTES:

- DRILLING ACCESS HOLE REQUIRED
- FISHWIRING REQUIRED

INSTALLATION STEPS

- 1) Remove undercoating from hitch mounting locations.
- 2) Enlarge existing hole under frame rail to 1" as shown above.
- 3) Fishwire 1 3/4" carriage bolts with spacers through access hole and outmounting hole. Raise hitch into position, remove fishwires, install 1/2" washers, and secure hitch with flange nuts.
- 4) Place remaining carriage bolt and spacer onto tow loop and place small spacer on hitch. Raise passenger side and secure with flange nut.
- 5) Torque all 1/2" fasteners to 75 lb-ft.

PERIODICALLY CHECK THIS RECEIVER HITCH TO ENSURE THAT ALL FASTENERS ARE TIGHT AND THAT ALL STRUCTURAL COMPONENTS ARE SOUND.

Curt Manufacturing Inc., warrants this product to be free of defects in material and/or workmanship at the time of retail purchase by the original purchaser. If the product is found to be defective, Curt Manufacturing Inc., may repair or replace the product, at their option, when the product is returned, prepaid, with proof of purchase. Alteration to, misuse of, or improper installation of this product voids the warranty. Curt Manufacturing Inc.'s liability is limited to repair or replacement of products found to be defective, and specifically excludes liability for incidental or consequential loss or damage.