



Safety glasses should be worn at all times while installing this product.

YEARS: 2013

MAKE: NISSAN

MODEL: SENTRA

STYLE: SEDAN

**WARNING: NEVER EXCEED YOUR VEHICLE MANUFACTURER'S RECOMMENDED TOWING CAPACITY**

**WEIGHT CARRYING:**  
 TRAILER WEIGHT: 2,000 LBS.  
 TONGUE WEIGHT: 200 LBS.

**WARNING:**  
 WE RECOMMEND THE USE OF 18050 STABILIZING STRAPS FOR ALL NON-TRAILER (WHEEL-LESS) LOADS. PLEASE SEE THE CURT CATALOG OR VISIT US ONLINE AT [WWW.CURTMFG.COM](http://WWW.CURTMFG.COM) FOR FURTHER INFORMATION.

**INSTALLATION TIME: 30/60 MIN.**

THE INSTALL TIME LISTED IS FOR PROFESSIONAL INSTALLERS. IF YOU ARE HESITANT TO UNDERTAKE THIS TASK ON YOUR OWN, CONTACT AN AUTHORIZED CURT INSTALLER FOR ADDITIONAL ASSISTANCE.

**INSTALLATION REQUIRES:**

SAFETY GLASSES	SCREW DRIVER	RATCHET
6" SOCKET EXTENSION	9/16" SOCKET	BOXED END WRENCH 9/16", 3/4"
TORQUE WRENCH		

**INSTALLATION TIPS:**

- BEFORE YOU BEGIN INSTALLATION, READ ALL INSTRUCTIONS THOROUGHLY.
- TO EASE INSTALLATION, 2 PEOPLE MAY BE REQUIRED.
- USING PROPER TOOLS WILL GREATLY IMPROVE THE QUALITY OF THE INSTALL AND REDUCE THE TIME REQUIRED.
- NEED HELP OR HAVE SOME QUESTIONS? CALL TECHNICAL SUPPORT AT 800.798.0813

**LEVEL OF DIFFICULTY: EASY**

EASY	MODERATE	CHALLENGING
	ENLARGE ACCESS HOLES	
	FISHWIRING REQUIRED	
	REVERSE FISHWIRING REQUIRED	

**VEHICLE PHOTO:**



REPRESENTATIVE PHOTO

**HITCH ILLUSTRATION:**

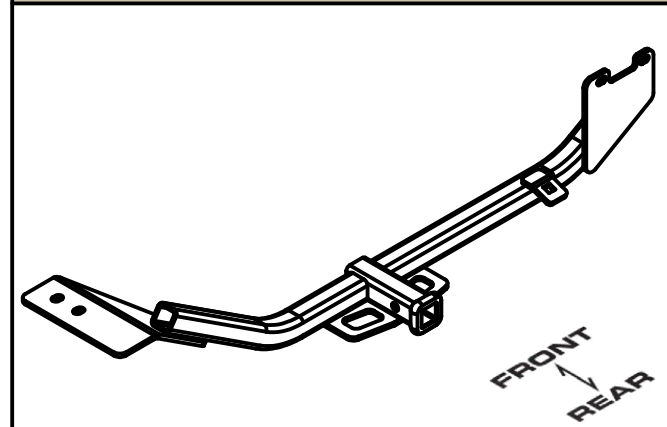

MAKE SURE YOUR HITCH MATCHES

**PERIODICALLY CHECK THIS RECEIVER HITCH TO ENSURE ALL FASTENERS ARE TIGHT AND ALL STRUCTURAL COMPONENTS ARE SOUND**

CURT Manufacturing LLC. warrants this product to be free of defects in material and/or workmanship at the time of retail purchase by the original purchaser. If the product is found to be defective, Curt Manufacturing LLC. may repair or replace the product at their option, when the product is returned, prepaid, with proof of purchase. Alteration to, misuse of, or improper installation of this product voids the warranty. Curt Manufacturing LLC.'s liability is limited to repair or replacement of products found to be defective, and specifically excludes liability for incidental or consequential loss or damage.

For more information log onto [www.curtmfg.com](http://www.curtmfg.com), & for helpful towing tips log onto [www.hitchinfo.com](http://www.hitchinfo.com)

## INSTALLATION WALKTHROUGH:

Parts List			
ITEM	QTY	PART NUMBER	DESCRIPTION
1	2	CM-SP6	.250 x 1.00 x 3.00" SQUARE HOLE SPACER
2	2	3/8 - 16 x 1 1/4	HEX BOLT
3	2	3/8"	WASHER
4	2	HFN3816P	3/8-16, HEX FLANGE NUT,PLAIN
5	2	1/2-13 x 1 1/2	CARRIAGE BOLT
6	3	HFN 1213	HEX FLANGE NUT
7	1	1/2 - 13 x 2"	CARRIAGE BOLT
8	1	CM-SP4	.250 x 1.50 x 3.00" SQUARE HOLE SPACER
9	2	1_2 FISHWIRE	1/2" FISHWIRE

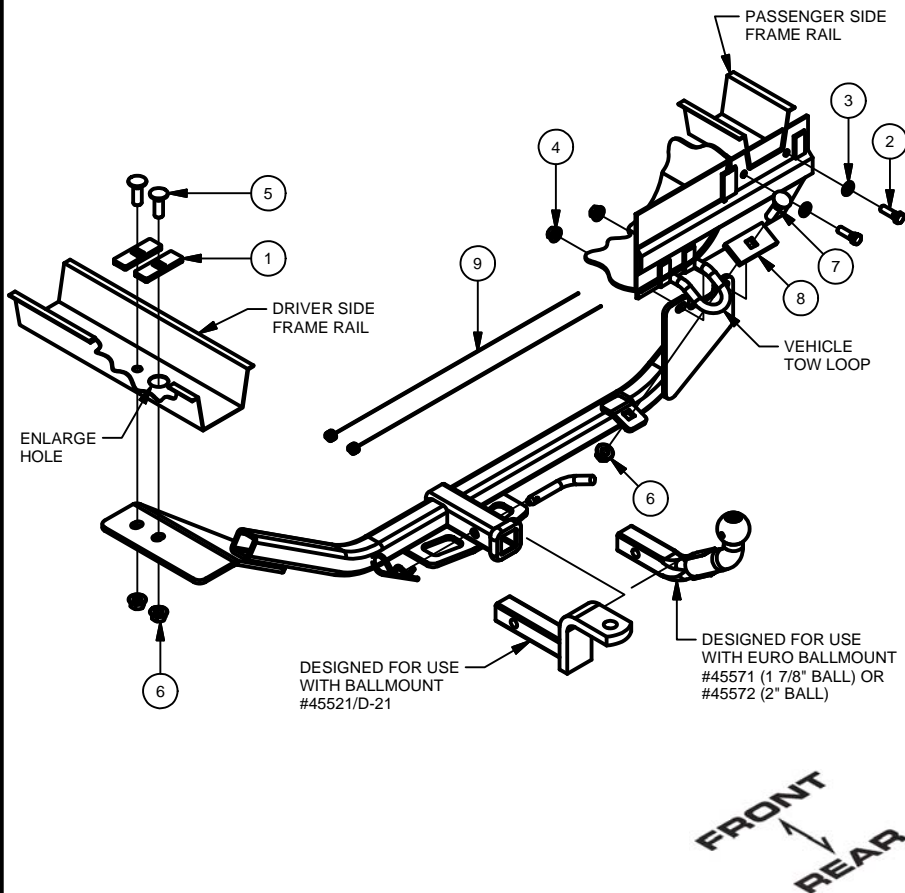

1. Locate (2) plastic fascia clips at rear of vehicle. Use flat head screwdriver to pry out and gain additional visibility and access to rear of vehicle frame. Retain clips for reinstallation.

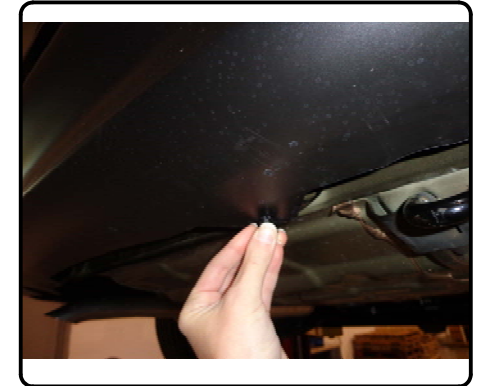

2. Use a die grinder to enlarge the rear hole in the driver side framerrail. This will be used for the access hole for fishwiring mounting hardware.

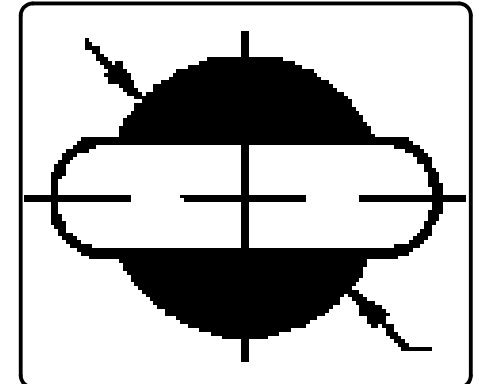

## INSTALLATION WALKTHROUGH:

3. Fishwire forward 1/2" mounting hardware through the frame access hole as shown.

See fishwire diagram for reference.

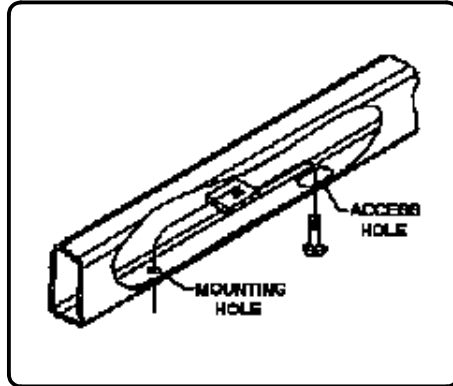

4. Reverse fishwire rearward 1/2" mounting hardware into the frame access hole as shown.

See reverse fishwire diagram for reference.

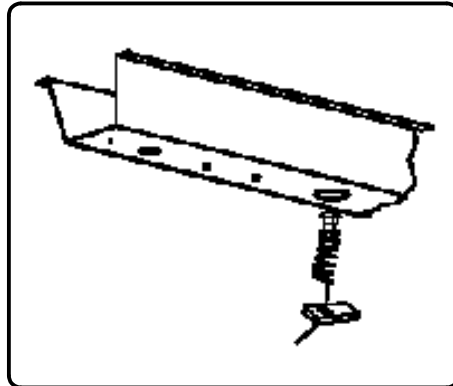
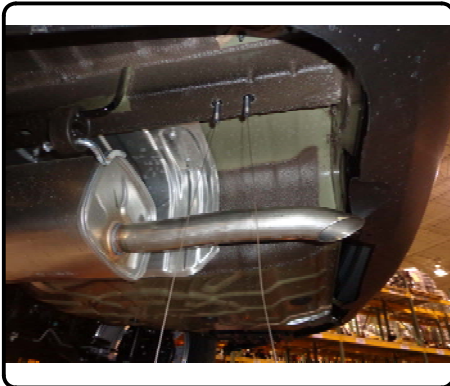

5. Raise hitch into position, attaching to the fishwired hardware on the driver side. 3/8" hardware will push through the rear of the vehicle frame on the passenger side and attach with a 9/16" socket as shown. Hold tightly on the back side with a boxed end wrench to secure.



6. Using 1/2" carriage bolt, nut and spacer, attach rear hitch plate to vehicle tow loop.

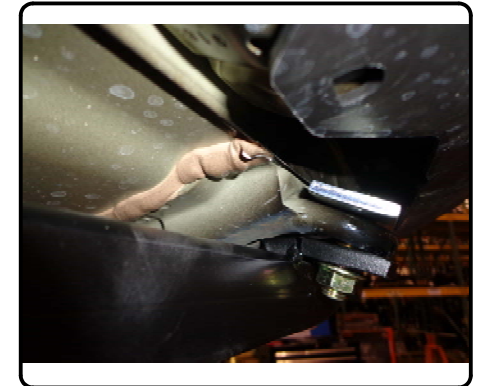
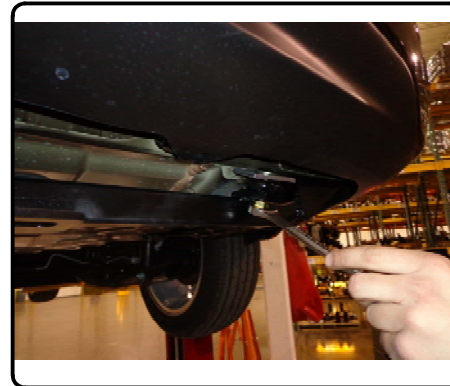

## INSTALLATION WALKTHROUGH:

7. Reattach (2) plastic fascia clips at rear of vehicle.

Torque all 1/2" hardware to 75 ft-lbs, torque all 3/8" hardware to 30 ft-lbs.



Installation is complete



**11349****NISSAN SENTRA**

11/15/12

**GROSS LOAD CAPACITY WHEN USED AS A WEIGHT CARRYING HITCH: 2,000 LBS. TRAILER WEIGHT & 200 LBS. TONGUE WEIGHT.****\*\*\*DO NOT EXCEED VEHICLE MANUFACTURER'S RECOMMENDED TOWING CAPACITY.\*\*\*****WARNING: ALL NON-TRAILER LOADS APPLIED TO THIS PRODUCT MUST BE SUPPORTED BY 18050 STABILIZING STRAPS.****\*\* FAILURE TO PROPERLY SUPPORT NON-TRAILER LOADS WILL VOID PRODUCT WARRANTY\*\*****HAVING INSTALLATION QUESTIONS? CALL TECHNICAL SUPPORT AT 1-800-798-0813**

Parts List			
ITEM	QTY	PART NUMBER	DESCRIPTION
1	2	CM-SP6	.250 x 1.00 x 3.00" SQUARE HOLE SPACER
2	2	3/8 - 16 x 1 1/4	HEX BOLT
3	2	3/8"	WASHER
4	2	HFN3816P	3/8-16, HEX FLANGE NUT,PLAIN
5	2	1/2-13 x 1 1/2	CARRIAGE BOLT
6	3	HFN 1213	HEX FLANGE NUT
7	1	1/2 - 13 x 2"	CARRIAGE BOLT
8	1	CM-SP4	.250 x 1.50 x 3.00" SQUARE HOLE SPACER
9	2	1_2 FISHWIRE	1/2" FISHWIRE

**FISHWIRE TECHNIQUE**

INSERT COILED END OF FISHWIRE TOOL THROUGH HITCH MOUNTING HOLE IN VEHICLE FRAME RAIL AND OUT THE ACCESS HOLE. PASS COILED END OF FISHWIRE THROUGH SPACER AND THREAD BOLT INTO COIL. KINK WIRE TO KEEP SPACER SEPARATE FROM BOLT AS SHOWN. PULL FISHWIRE, SPACER, AND BOLT THROUGH FRAME AND OUT MOUNTING HOLE. USE FISHWIRE TO GUIDE HITCH DURING MOUNTING AND PREVENT LOSS OF BOLT / SPACER INSIDE FRAME RAIL.

\*\*NOTE: SOME VEHICLES MAY FISHWIRE THROUGH END OF FRAME\*\*

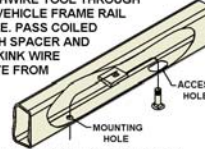
**TOOLS REQUIRED**

SCREWDRIVER
RATCHET
6" SOCKET EXTENSION
9/16" SOCKET
9/16", 3/4" BOXED END WRENCH
TORQUE WRENCH

**REVERSE PULL FISHWIRE TECHNIQUE**

ATTACH FISHWIRE TO CARRIAGE BOLT AND SLIDE SPACER ONTO FISHWIRE. PUSH THE BOLT THRU THE HOLE FOLLOWED BY THE SPACER (AS SHOWN). PULL BOLT BACK INTO POSITION, PROTRUDING FROM THE FRAME.

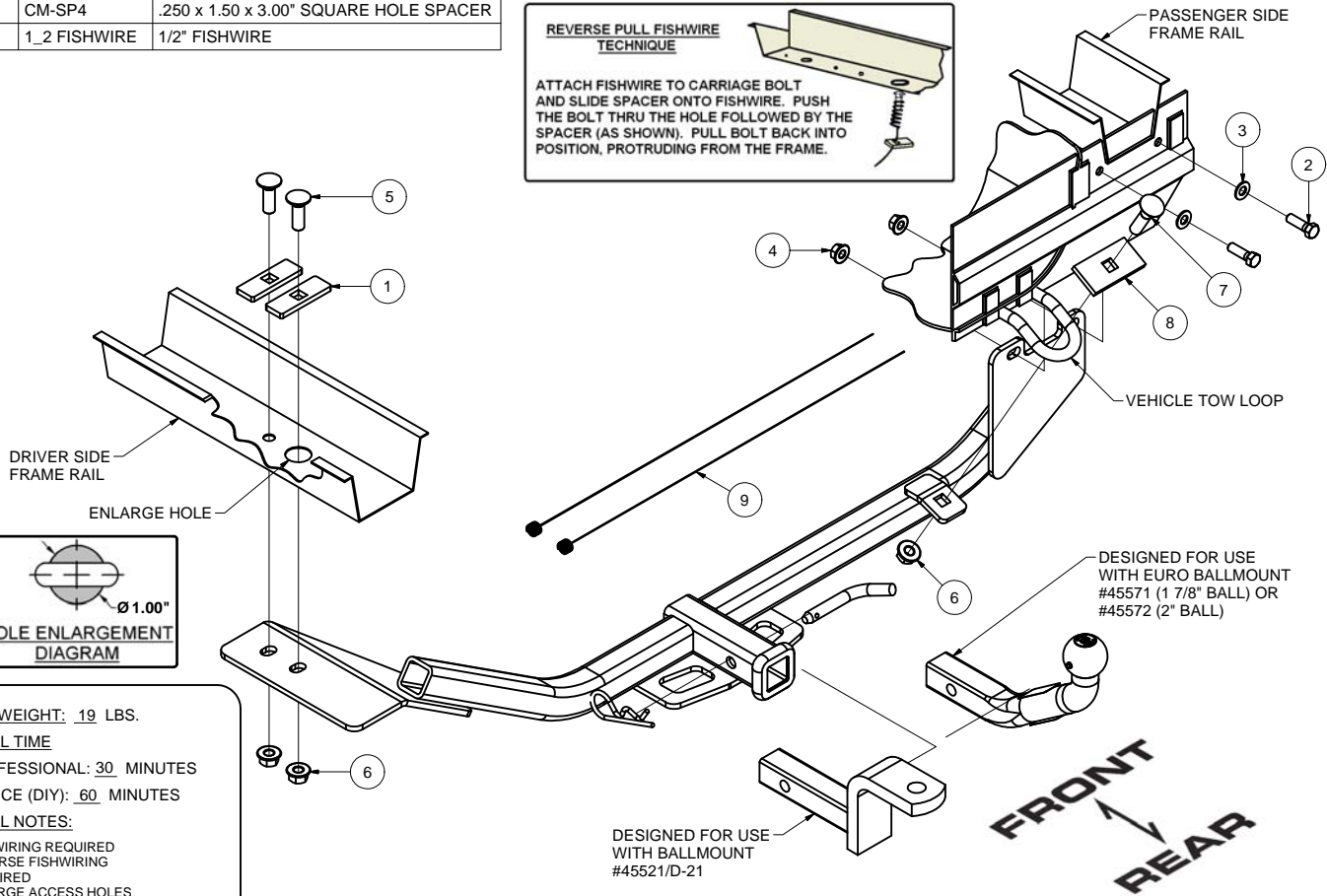
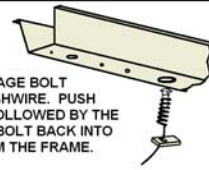
**HITCH WEIGHT: 19 LBS.****INSTALL TIME**

PROFESSIONAL: 30 MINUTES

NOVICE (DIY): 60 MINUTES

**INSTALL NOTES:**

- FISHWIRING REQUIRED
- REVERSE FISHWIRING REQUIRED
- ENLARGE ACCESS HOLES

**INSTALLATION STEPS**

1. Locate (2) plastic fascia clips at rear of vehicle. Use flat head screwdriver to pry out and gain additional visibility and access to rear of vehicle frame. Retain clips for reinstallation.
2. Use a die grinder to enlarge the rear hole in the driver side framerail. This will be used for the access hole for fishwiring mounting hardware.
3. Fishwire forward 1/2" mounting hardware through the frame access hole as shown. See fishwire diagram for reference.
4. Reverse fishwire rearward 1/2" mounting hardware into the frame access hole as shown. See reverse fishwire diagram for reference.
5. Raise hitch into position, attaching to the fishwired hardware on the driver side. 3/8" hardware will push through the rear of the vehicle frame on the passenger side and attach with a 9/16" socket. Hold tightly on the back side with a boxed end wrench to secure.
6. Using 1/2" carriage bolt, nut and spacer, attach rear hitch plate to vehicle tow loop.
7. Reattach (2) plastic fascia clips at rear of vehicle.
8. Torque all 1/2" hardware to 75 ft-lbs, torque all 3/8" hardware to 30 ft-lbs.

**PERIODICALLY CHECK THIS RECEIVER HITCH TO ENSURE THAT ALL FASTENERS ARE TIGHT AND THAT ALL STRUCTURAL COMPONENTS ARE SOUND.**

Curt Manufacturing LLC., warrants this product to be free of defects in material and/or workmanship at the time of retail purchase by the original purchaser. If the product is found to be defective, Curt Manufacturing LLC., may repair or replace the product, at their option, when the product is returned, prepaid, with proof of purchase. Alteration to, misuse of, or improper installation of this product voids the warranty. Curt Manufacturing LLC.'s liability is limited to repair or replacement of products found to be defective, and specifically excludes liability for incidental or consequential loss or damage.