

11380 / 247380**CHEVROLET CORVETTE**

6/21/2011

EXCLUDES Z51 CHASSIS PACKAGE

GROSS LOAD CAPACITY WHEN USED AS A WEIGHT CARRYING HITCH: 2,000 LBS. TRAILER WEIGHT & 200 LBS. TONGUE WEIGHT.
*****DO NOT EXCEED VEHICLE MANUFACTURER'S RECOMMENDED TOWING CAPACITY.*****

Parts List			
ITEM	QTY	PART NUMBER	DESCRIPTION
1	1	1/2"	FISHWIRE TOOL
2	4	1/2-13 x 1 3/4	CARRIAGE BOLT
3	4	HFN 1213	HEX FLANGE NUT
4	4	CM-SP4	.250 x 1.50 x 3.00" SQUARE HOLE SPACER

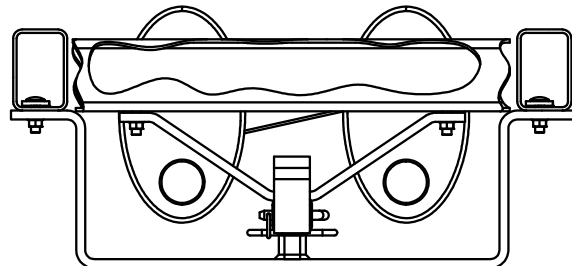

HITCH SHOWN WHEN CORRECTLY INSTALLED

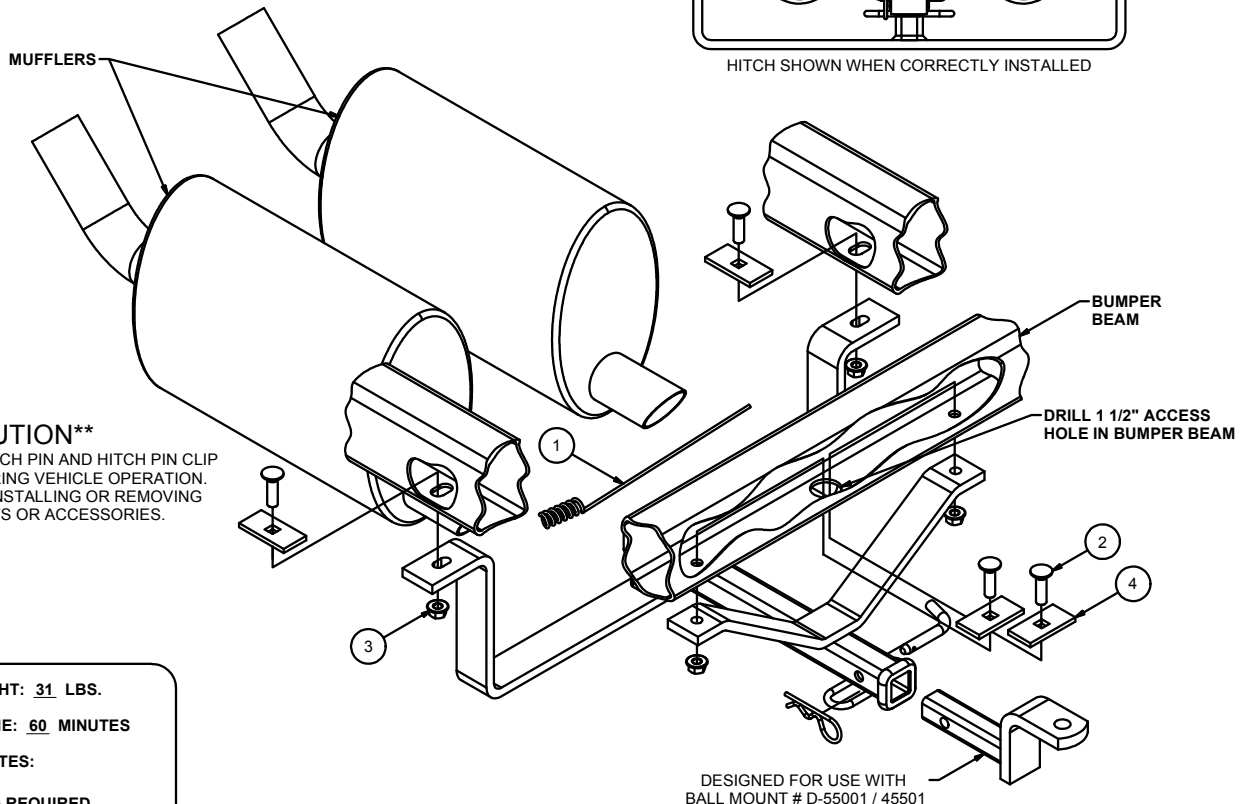
****CAUTION****

HITCH, BALL MOUNT, HITCH PIN AND HITCH PIN CLIP MAY BECOME HOT DURING VEHICLE OPERATION. USE CAUTION WHEN INSTALLING OR REMOVING ANY BALL MOUNTS OR ACCESSORIES.

HITCH WEIGHT: 31 LBS.INSTALL TIME: 60 MINUTES

INSTALL NOTES:

- DRILLING REQUIRED
- LOWER EXHAUST

DESIGNED FOR USE WITH
 BALL MOUNT # D-55001 / 45501

INSTALLATION STEPS

1. Enlarge existing slots in the frame to allow spacers to pass through.
2. Fishwire 1/2" carriage bolts and spacers through enlarged slots by pushing the bolt and spacer through the slot then pulling them back into position.
3. Drill a 1 1/2" access hole in the center of the bumper beam between the mufflers as shown.
4. Remove (4) bolts holding mufflers in place, let mufflers hang loose. (Re-install when finished with hitch)
5. Raise hitch into position by twisting sideways between exhaust tips and rotating to pass between mufflers. Secure with flange nuts, finger tighten.
6. Using the hitch as a template, drill (2) 17/32" holes in bumper beam.
7. Fishwire remaining fasteners through access hole and out 17/32" drilled holes.
8. Install remaining flange nuts, Torque all 1/2" fasteners to 75 lb-ft.

PERIODICALLY CHECK THIS RECEIVER HITCH TO ENSURE THAT ALL FASTENERS ARE TIGHT AND THAT ALL STRUCTURAL COMPONENTS ARE SOUND.

Curt Manufacturing Inc., warrants this product to be free of defects in material and/or workmanship at the time of retail purchase by the original purchaser. If the product is found to be defective, Curt Manufacturing Inc., may repair or replace the product, at their option, when the product is returned, prepaid, with proof of purchase. Alteration to, misuse of, or improper installation of this product voids the warranty. Curt Manufacturing Inc.'s liability is limited to repair or replacement of products found to be defective, and specifically excludes liability for incidental or consequential loss or damage.