

11589**84-87 HONDA CIVIC (CRX ONLY)**

11/6/2009

GROSS LOAD CAPACITY WHEN USED AS A WEIGHT CARRYING HITCH: 1,000 LBS. TRAILER WEIGHT & 100 LBS. TONGUE WEIGHT.

DO NOT EXCEED VEHICLE MANUFACTURER'S RECOMMENDED TOWING CAPACITY.

WARNING: ALL NON-TRAILER LOADS APPLIED TO THIS PRODUCT MUST BE SUPPORTED BY AUXILIARY STABILIZING STRAPS.

** FAILURE TO PROPERLY SUPPORT NON-TRAILER LOADS WILL VOID PRODUCT WARRANTY**

HAVING INSTALLATION QUESTIONS? CALL TECHNICAL SUPPORT AT 1-800-798-0813

Parts List			
ITEM	QTY	PART NUMBER	DESCRIPTION
1	1	3/8 - 16 x 4	HEX BOLT
2	4	3/8 - 16 x 1 1/4	HEX BOLT
3	4	3/8"	WASHER
4	6	3/8"	LOCK WASHER
5	6	3/8 - 16	HEX NUT
6	1	3/8 - 16 x 1 3/4	HEX BOLT
7	2	3/8"	FENDER WASHER
8	1	CM-11589-TB	.375 x 1.50 TAIL BRACKET

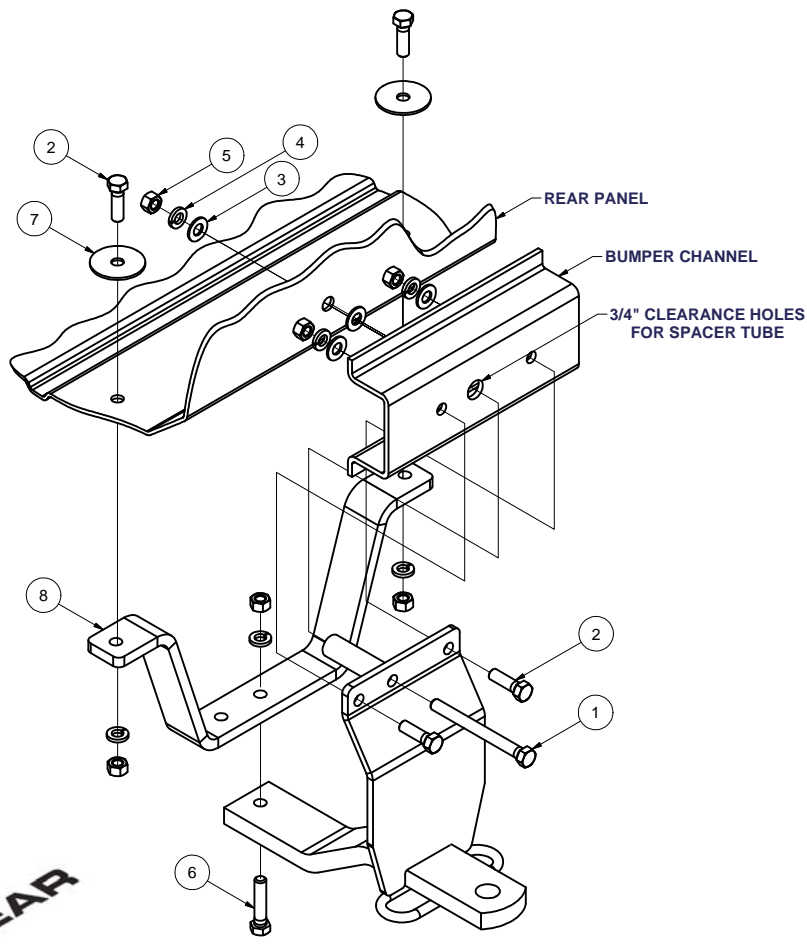

HITCH WEIGHT: 11 LBS.

INSTALL TIME

PROFESSIONAL: 45 MINUTES

NOVICE (DIY): 90 MINUTES

INSTALL NOTES:

- DRILLING REQUIRED
- REMOVE LICENSE PLATE

FRONT
 ↕
REAR

INSTALLATION STEPS

1. Remove the license plate. Clear the trunk area. Locate and mark the car's centerline on the rear bumper channel.
2. Assemble the hitch crossmember to the tongue, offset using fasteners as shown. Hold the hitch centered and level against the car so the spacer tube rests against the bumper channel. Mark the bumper channel for one 3/4" clearance hole for spacer tube. Drill bumper channel for spacer tube. Clearance holes may not fall centered on the channel.
3. Position the hitch on the car with spacer tube passing through the bumper channel. Drill the rear panel for one 3/8" diameter hole by drilling directly through spacer tube. Drill two additional 3/8" diameter holes through the bumper channel matching the hitch bracket. Bolt the hitch to the rear panel and bumper channel making sure to use flat washers on BOTH sides of the panel as shown.
4. Drill the trunk floor two places through hitch crossmember for 3/8" screws. Fasten the hitch to the floor using fasteners as shown. Make sure the fender washers are installed INSIDE the trunk; opposite the hitch.
5. Torque all 3/8" fasteners to 30 lb-ft.

PERIODICALLY CHECK THIS RECEIVER HITCH TO ENSURE THAT ALL FASTENERS
 ARE TIGHT AND THAT ALL STRUCTURAL COMPONENTS ARE SOUND.

Curt Manufacturing Inc., warrants this product to be free of defects in material and/or workmanship at the time of retail purchase by the original purchaser. If the product is found to be defective, Curt Manufacturing Inc., may repair or replace the product, at their option, when the product is returned, prepaid, with proof of purchase. Alteration to, misuse of, or improper installation of this product voids the warranty. Curt Manufacturing Inc.'s liability is limited to repair or replacement of products found to be defective, and specifically excludes liability for incidental or consequential loss or damage.