

11824 01-04 MERCEDES-BENZ C-CLASS WAGON & SEDAN

2/25/2010

GROSS LOAD CAPACITY WHEN USED AS A WEIGHT CARRYING HITCH: 2,500 LBS. TRAILER WEIGHT & 200 LBS. TONGUE WEIGHT.

DO NOT EXCEED VEHICLE MANUFACTURER'S RECOMMENDED TOWING CAPACITY.

WARNING: ALL NON-TRAILER LOADS APPLIED TO THIS PRODUCT MUST BE SUPPORTED BY 18050 STABILIZING STRAPS.

** FAILURE TO PROPERLY SUPPORT NON-TRAILER LOADS WILL VOID PRODUCT WARRANTY**

HAVING INSTALLATION QUESTIONS? CALL TECHNICAL SUPPORT AT 1-800-798-0813

TOOLS REQUIRED

7/16" DRILL BIT

DRILL

9/16", 10mm & 16mm SOCKETS

11/16" OPEN END WRENCH

12" EXTENSION

RATCHET

TORQUE WRENCH

FISHWIRE TECHNIQUE

INSERT COILED END OF FISHWIRE TOOL THROUGH HITCH MOUNTING HOLE IN VEHICLE FRAME RAIL AND OUT THE ACCESS HOLE. PASS COILED END OF FISHWIRE THROUGH SPACER AND THREAD BOLT INTO COIL. KINK WIRE TO KEEP SPACER SEPARATE FROM BOLT AS SHOWN. PULL FISHWIRE, SPACER, AND BOLT THROUGH FRAME AND OUT MOUNTING HOLE. USE FISHWIRE TO GUIDE HITCH DURING MOUNTING AND PREVENT LOSS OF BOLT / SPACER INSIDE FRAME RAIL.

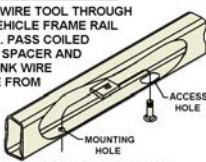

NOTE: SOME VEHICLES MAY FISHWIRE THROUGH END OF FRAME

HITCH WEIGHT: 18 LBS.

INSTALL TIME

PROFESSIONAL: 60 MINUTES

NOVICE (DIY): 120 MINUTES

INSTALL NOTES:

- BUMPER REMOVAL REQUIRED
- DRILLING REQUIRED
- FISHWIRE HARDWARE

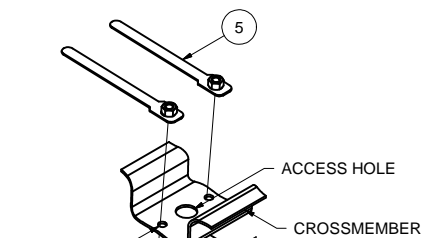

Parts List			
ITEM	QTY	PART NUMBER	DESCRIPTION
1	2	CM-438-FW	7/16" FISHWIRE TOOL
2	2	7/16-14	HEX FLANGE NUT
3	2	3/8-16 X 1 1/2	HEX BOLT
4	2	3/8"	CONICAL TOOTHED WASHER
5	2	3_8-16 TAB NUT	HANDLE NUT
6	2	7/16-14 x 1 1/2	CARRIAGE BOLT
7	2	CM-SP108	2.00 X 0.88 X .125 SPACER

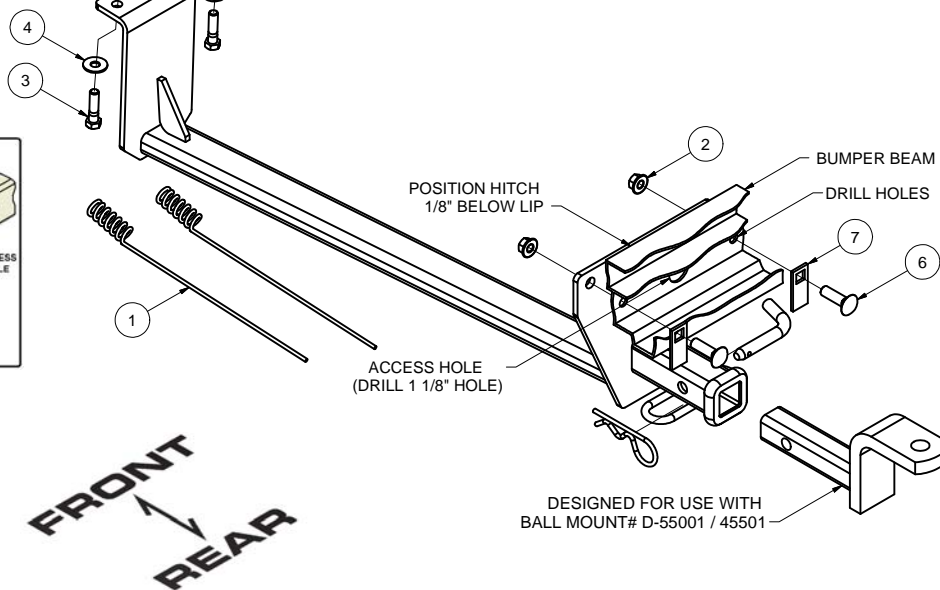

INSTALLATION STEPS

1. Position the hitch on the vehicle as shown. Align the center hole in the mounting plate with the hole in the crossmember. Square and center the hitch and mark the bumper beam and crossmember for holes.

2. It will be necessary to temporarily remove rear bumper assembly to drill holes.

BUMPER REMOVAL:

- Remove plastic threshold panel at base of trunk lid / rear door (wagon).
- Pull away interior soft panels enough to access interior body at rear, left, and right sides.
- Remove (6) 10mm nuts securing the steel bumper reinforcement.
- Remove (2) 8mm nuts above these 10mm nuts.
- Remove the screws securing the bumper cover at the forward inside lower corner of each tail light assembly.
- At each wheel opening (outside car) remove metal screw at top edge of bumper fascia.
- CAUTION:** There may be wiring running between chassis and bumper assembly. Bumper assembly should be placed beam side up close to car on a soft surface for drilling without disconnecting this cable.

3. Drill all mounting holes using a 7/16" drill bit.

4. Make one access hole 1 1/8" diameter centered between holes in bumper beam. Fishwire a 7/16-14 carriage bolt and CM-SP108 spacer through access hole. (See FISHWIRE TECHNIQUE diagram)

5. Reinstall bumper.

6. Remove fishwires and install fasteners as shown.

7. Torque all 7/16" hardware to 50 lb.-ft. and all 3/8" hardware to 30 lb.-ft.
PERIODICALLY CHECK THIS RECEIVER HITCH TO ENSURE THAT ALL FASTENERS ARE TIGHT AND THAT ALL STRUCTURAL COMPONENTS ARE SOUND.

Curt Manufacturing Inc., warrants this product to be free of defects in material and/or workmanship at the time of retail purchase by the original purchaser. If the product is found to be defective, Curt Manufacturing Inc., may repair or replace the product, at their option, when the product is returned, prepaid, with proof of purchase. Alteration to, misuse of, or improper installation of this product voids the warranty. Curt Manufacturing Inc.'s liability is limited to repair or replacement of products found to be defective, and specifically excludes liability for incidental or consequential loss or damage.