

12005

78-87 BUICK REGAL RWD, 78-81 CENTURY SEDAN AND WAGON
77-88 CHEVROLET MONTE CARLO, 78-88 EL CAMINO
78-83 OLDS CUTLASS CIERA CRUISER, 78-88 CUTLASS SUPREME
82-86 PONTIAC BONNEVILLE, 78-87 GRAND PRIX, 78-81 MONTANA

1/19/2010

GROSS LOAD CAPACITY WHEN USED AS A WEIGHT CARRYING HITCH: 3,500 LBS. TRAILER WEIGHT & 350 LBS. TONGUE WEIGHT.

DO NOT EXCEED VEHICLE MANUFACTURER'S RECOMMENDED TOWING CAPACITY.

WARNING: ALL NON-TRAILER LOADS APPLIED TO THIS PRODUCT MUST BE SUPPORTED BY 18050 STABILIZING STRAPS.

** FAILURE TO PROPERLY SUPPORT NON-TRAILER LOADS WILL VOID PRODUCT WARRANTY**

HAVING INSTALLATION QUESTIONS? CALL TECHNICAL SUPPORT AT 1-800-798-0813

Parts List			
ITEM	QTY	PART NUMBER	DESCRIPTION
1	2	1/2 - 13 x 2 1/4	CARRIAGE BOLT
2	2	FW12	FW, 12, ZP
3	2	1/2"	LOCK WASHER
4	1	1/2"	FISHWIRE TOOL
5	3	3/8 - 16 x 1 1/4	HEX BOLT
6	6	3/8"	WASHER
7	2	CM-SP33	.250 x 1.50 x 2.00" SQUARE HOLE SPACER
8	2	1/2-13	HEX NUT
9	3	3/8-16	NYLOCK HEX NUT

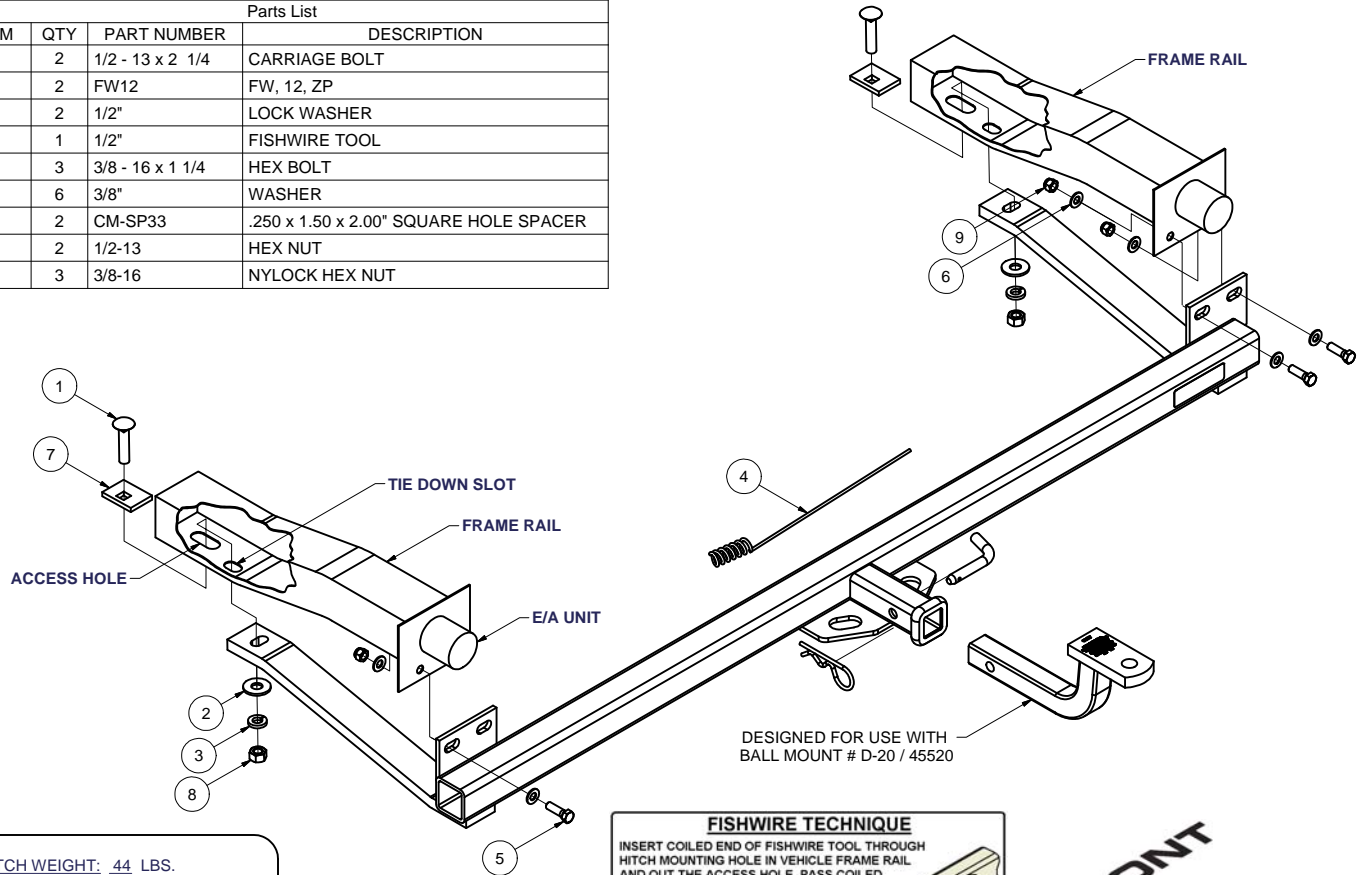

HITCH WEIGHT: 44 LBS.

INSTALL TIME

PROFESSIONAL: 45 MINUTES

NOVICE (DIY): 90 MINUTES

INSTALL NOTES:

HOLE ENLARGEMENT REQUIRED

FISHWIRE TECHNIQUE

INSERT COILED END OF FISHWIRE TOOL THROUGH HITCH MOUNTING HOLE IN VEHICLE FRAME RAIL AND OUT THE ACCESS HOLE. PASS COILED END OF FISHWIRE THROUGH SPACER AND THREAD BOLT INTO COIL. KINK WIRE TO KEEP SPACER SEPARATE FROM BOLT AS SHOWN. PULL FISHWIRE, SPACER, AND BOLT THROUGH FRAME AND OUT MOUNTING HOLE. USE FISHWIRE TO GUIDE HITCH MOUNTING AND PREVENT LOSS OF BOLT / SPACER INSIDE FRAME RAIL.

NOTE: SOME VEHICLES MAY FISHWIRE THROUGH END OF FRAME

INSTALLATION STEPS

- 1) Remove three lower bolts which attach the E/A unit to frame. Two are on passenger side and one on driver side. **(Note: On station wagon models, remove the center most bolt from the bottom of the bumper.)**
- 2) Enlarge E/A bolt holes with a 3/8 drill bit.
- 3) Position on vehicle. Install 3/8" bolts and washers through hitch and enlarged E/A attachment holes as shown. Loosely install flat washers and locknuts as shown.
- 4) Fishwire 1/2" carriage bolts and spacer blocks up through frame access holes and down through tie down slots in each frame rail. El Camino and Caballero models require bumper to be removed with E/A assembly so the bolts can be fishwired from the rear frame opening. Install remaining fasteners as shown.
- 5) Torque 1/2" fasteners to 75 lb.-ft. Torque 3/8" fasteners to 32 lb.-ft.

PERIODICALLY CHECK THIS RECEIVER HITCH TO ENSURE THAT ALL FASTENERS ARE TIGHT AND THAT ALL STRUCTURAL COMPONENTS ARE SOUND.

Curt Manufacturing Inc., warrants this product to be free of defects in material and/or workmanship at the time of retail purchase by the original purchaser. If the product is found to be defective, Curt Manufacturing Inc., may repair or replace the product, at their option, when the product is returned, prepaid, with proof of purchase. Alteration to, misuse of, or improper installation of this product voids the warranty. Curt Manufacturing Inc.'s liability is limited to repair or replacement of products found to be defective, and specifically excludes liability for incidental or consequential loss or damage.