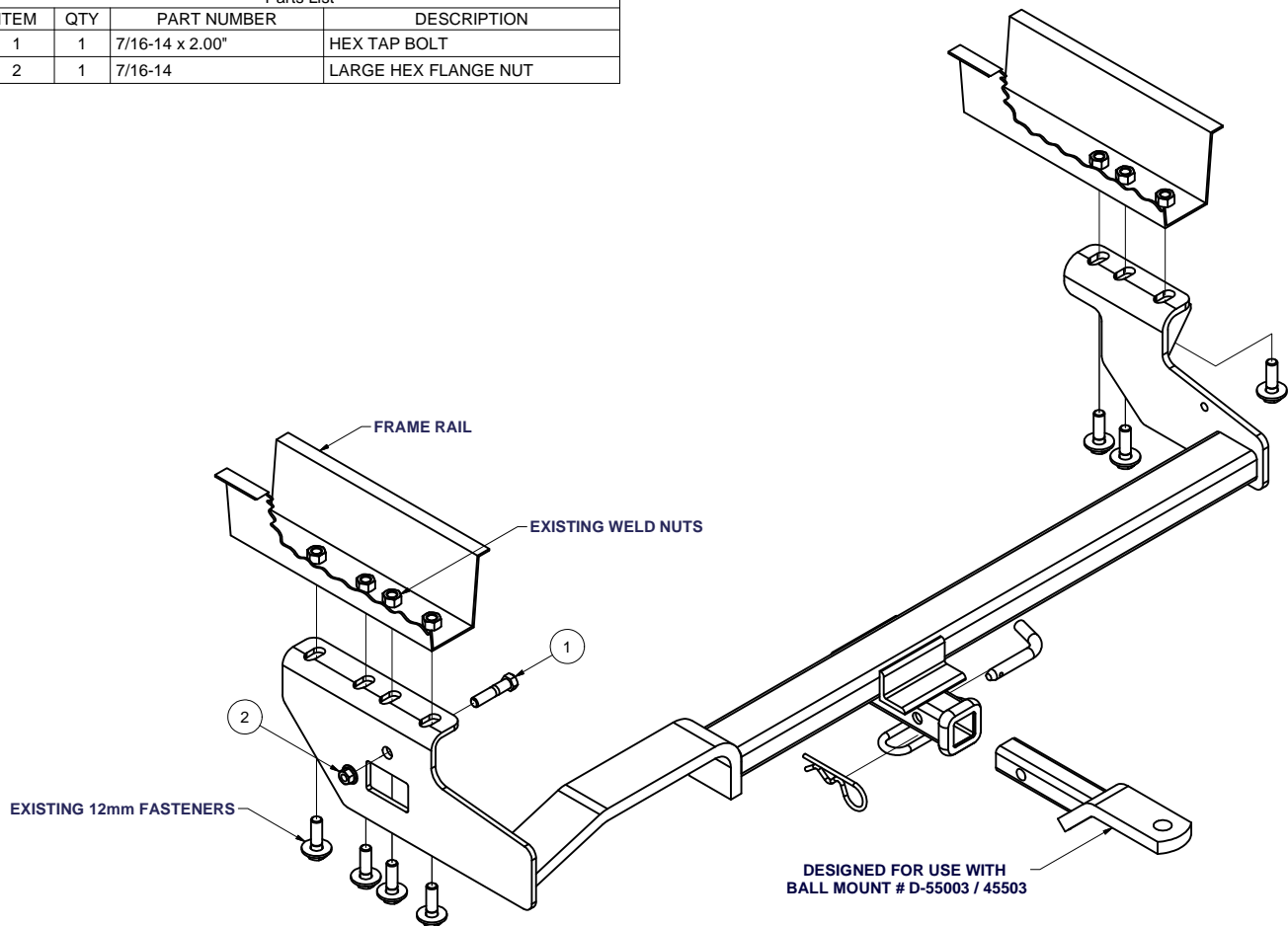

12038 / 36311 / 367038**SUBARU FORESTER**

7/5/2007

GROSS LOAD CAPACITY WHEN USED AS A WEIGHT CARRYING HITCH: 3500 LBS. TRAILER WEIGHT & 350 LBS. TONGUE WEIGHT.
 DO NOT EXCEED VEHICLE MANUFACTURER'S RECOMMENDED TOWING CAPACITY.

Parts List			
ITEM	QTY	PART NUMBER	DESCRIPTION
1	1	7/16-14 x 2.00"	HEX TAP BOLT
2	1	7/16-14	LARGE HEX FLANGE NUT

HITCH WEIGHT: 36 LBS.INSTALL TIME: 45 MINUTES

INSTALL NOTES:

NO DRILLING REQUIRED**INSTALLATION STEPS**

- 1) Lower carbon canister and its bracket from frame rail (passenger side). Remove tie down brackets from each frame rail. Disconnect rearmost exhaust hanger and remove hanger bracket from frame rail, remove center fascia bracket if present. Return tie down and exhaust bracket to customer. The 12mm fasteners will be reused to mount hitch.
- 2) Mount hitch to vehicle sandwiching canister bracket between hitch and right frame rail. Use vehicle's 12mm fasteners (7). Modify tow hook pad as needed to provide clearance for hitch installation.
- 3) Re-mount rubber exhaust hanger directly to hitch left side plate using fasteners provided. Re-mount carbon canister to its bracket.
- 4) Torque 12mm fasteners to 60 lb.-ft. Torque 7/16" fasteners to 50 lb.-ft.

PERIODICALLY CHECK THIS RECEIVER HITCH TO ENSURE THAT ALL FASTENERS
 ARE TIGHT AND THAT ALL STRUCTURAL COMPONENTS ARE SOUND.

Curt Manufacturing Inc., warrants this product to be free of defects in material and/or workmanship at the time of retail purchase by the original purchaser. If the product is found to be defective, Curt Manufacturing Inc., may repair or replace the product, at their option, when the product is returned, prepaid, with proof of purchase. Alteration to, misuse of, or improper installation of this product voids the warranty. Curt Manufacturing Inc.'s liability is limited to repair or replacement of products found to be defective, and specifically excludes liability for incidental or consequential loss or damage.

10/23/2006 1/26/06