

12041

91-96 BUICK ROADMASTER ESTATE WAGON, 77-90 BUICK ESTATE AND LE SABRE S/W
77-96 CHEVROLET CAPRICE WAGON, IMPALA S/W, 77-92 OLDSMOBILE CUSTOM CRUISER
83-86 PONTIAC SAFARI S/W AND PONTIAC PARISENE S/W

10/14/2009

GROSS LOAD CAPACITY WHEN USED AS A WEIGHT CARRYING HITCH: 3,500 LBS. TRAILER WEIGHT & 350 LBS. TONGUE WEIGHT.

DO NOT EXCEED VEHICLE MANUFACTURER'S RECOMMENDED TOWING CAPACITY.

WARNING: ALL NON-TRAILER LOADS APPLIED TO THIS PRODUCT MUST BE SUPPORTED BY AUXILIARY STABILIZING STRAPS.

** FAILURE TO PROPERLY SUPPORT NON-TRAILER LOADS WILL VOID PRODUCT WARRANTY**

HAVING INSTALLATION QUESTIONS? CALL TECHNICAL SUPPORT AT 1-800-798-0813

Parts List			
ITEM	QTY	PART NUMBER	DESCRIPTION
1	4	3/8-16 x 1 1/2	HEX BOLT
2	4	3/8"	CONICAL TOOTHED WASHER
3	4	3/8-16	HEX FLANGE NUT
4	2	7_16 - 14 x 2.50 x 2.75 C-C	U-BOLT
5	4	7/16-14	HEX FLANGE NUT

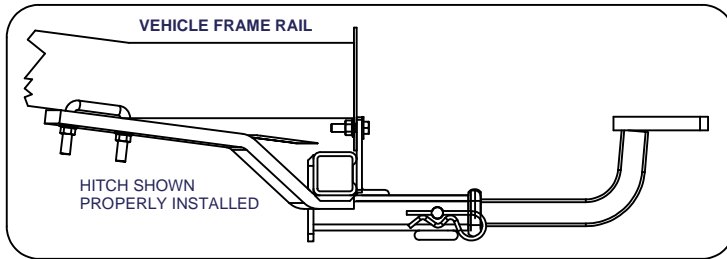
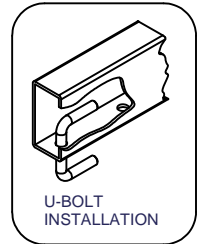

USE HITCH HOLES AS A TEMPLATE
TO DRILL HOLES INTO FRAME RAIL

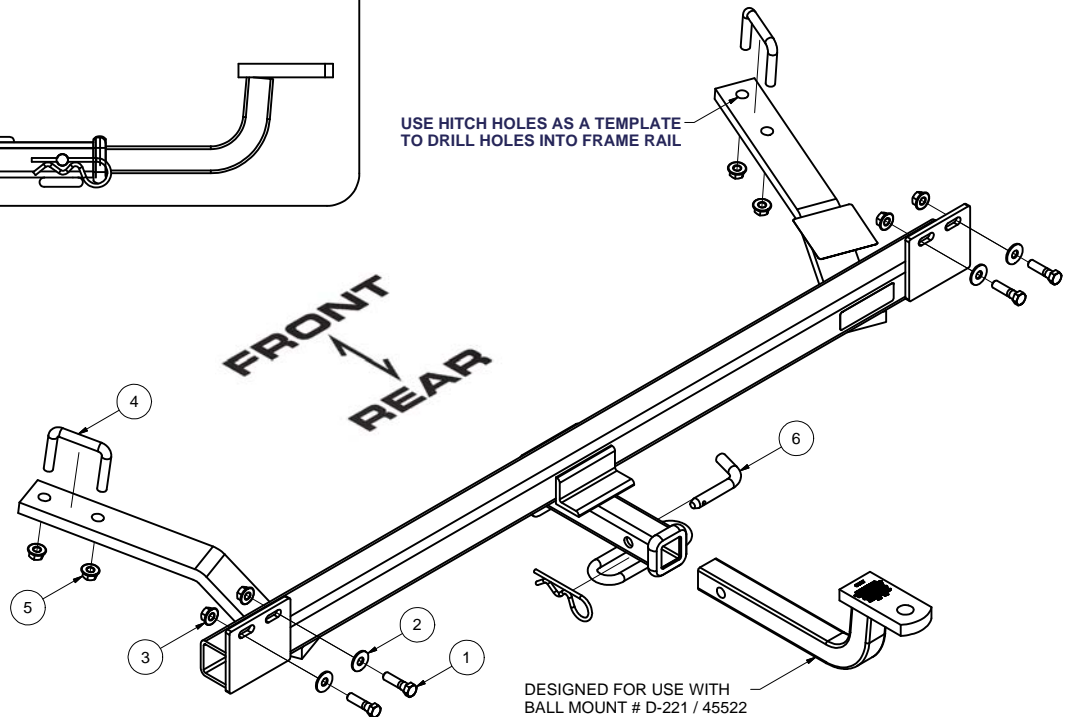

HITCH WEIGHT: 40 LBS.

INSTALL TIME

PROFESSIONAL: 40 MINUTES

NOVICE (DIY): 80 MINUTES

INSTALL NOTES:

INSTALLATION STEPS

- 1) Remove the lower two bolts from each bumper shock mount located at the end of each frame rail. Discard the bolts. The holes in the bumper mount must accept a 3/8" diameter bolt, enlarge as needed.
- 2) Attach the hitch assembly to the open holes in each shock mount . Do not tighten bolts at this time.
- 3) Position the forward arms of the hitch assembly up against the bottom of the vehicle frame rails. Drill two 1/2" attachment holes in each frame rail using the holes in hitch frame brackets as guides.
- 4) Insert a 7/16" U-Bolt as shown above into each vehicle frame at the previously drilled holes . Bolt hitch arms to vehicle frame as illustrated. Do not over tighten the U-Bolts. Do not tighten with an impact wrench. Hand tighten the U-bolts to 55 lb.-ft of torque.
- 5) Torque the 3/8" bolts to 30 lb.-ft.

PERIODICALLY CHECK THIS RECEIVER HITCH TO ENSURE THAT ALL FASTENERS
ARE TIGHT AND THAT ALL STRUCTURAL COMPONENTS ARE SOUND.

Curt Manufacturing Inc., warrants this product to be free of defects in material and/or workmanship at the time of retail purchase by the original purchaser. If the product is found to be defective, Curt Manufacturing Inc., may repair or replace the product, at their option, when the product is returned, prepaid, with proof of purchase. Alteration to, misuse of, or improper installation of this product voids the warranty. Curt Manufacturing Inc.'s liability is limited to repair or replacement of products found to be defective, and specifically excludes liability for incidental or consequential loss or damage.