

12051 CHEVROLET MALIBU LS, LT & LTZ / SATURN AURA

5/10/2010

GROSS LOAD CAPACITY WHEN USED AS A WEIGHT CARRYING HITCH: 3500 LBS. TRAILER WEIGHT & 300 LBS. TONGUE WEIGHT.
 DO NOT EXCEED VEHICLE MANUFACTURER'S RECOMMENDED TOWING CAPACITY.

Parts List			
ITEM	QTY	PART NUMBER	DESCRIPTION
1	2	1/2-13 x 1 3/4	CARRIAGE BOLT
2	2	CM-SP6	.250 x 1.00 x 3.00" SQUARE HOLE SPACER
3	2	HFN 1213	HEX FLANGE NUT
4	2	3/8-16 x 1 1/2	CARRIAGE BOLT
5	2	CM-SP18	.250 x 1.00 x 2.00" SQUARE HOLE SPACER
6	2	CM-SP50	.250 x 1.00 x 1.50" ROUND HOLE SPACER
7	2	HFN3816	HEX FLANGE NUT
8	2	3_8 FISHWIRE	3/8" FISHWIRE
9	2	1_2 FISHWIRE	1/2" FISHWIRE

TOOLS REQUIRED
DRILL
17/32" DRILL BIT
9/16" SOCKET
3/4" SOCKET
RATCHET
TORQUE WRENCH
BLACK SHARPIE

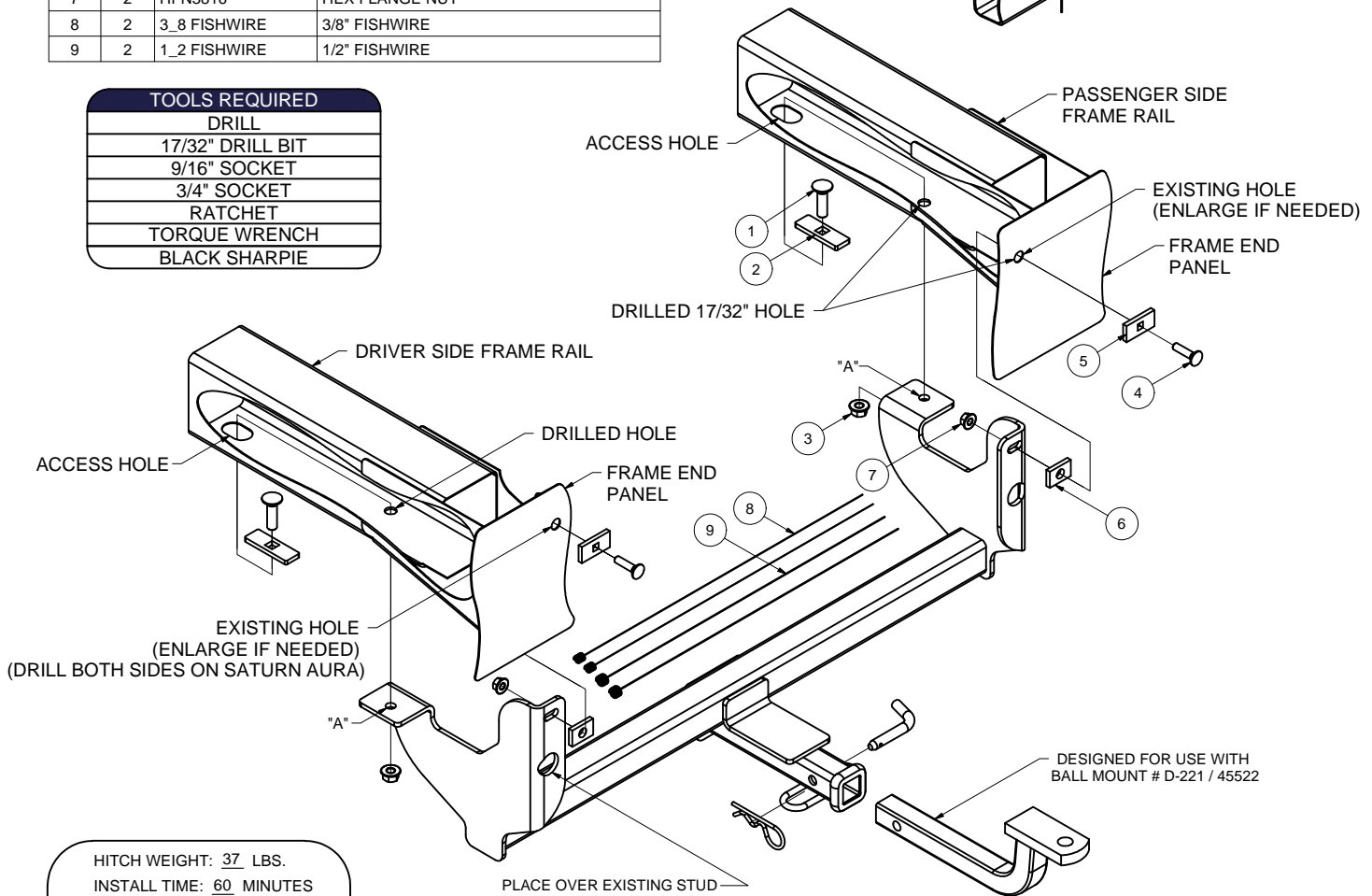
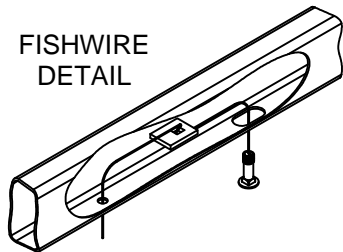

HITCH WEIGHT: 37 LBS.
 INSTALL TIME: 60 MINUTES
 INSTALL NOTES:
 - DRILLING REQUIRED
 - FISHWIRE HARDWARE

- Vehicle needs to be jacked up if installation is from ground level.
 - On models with dual exhaust, lower the exhaust to ease installation.

INSTALLATION STEPS

1. Feed fishwire through end panel. Slide spacer (Item 5) onto fishwire then thread carriage bolt (Item 4) onto fishwire. Gently pull spacer plate and carriage bolt into position. Thread spacer (Item 6) onto fishwire. Leave fishwire attached to carriage bolt to hold parts in position.
2. Raise the hitch into position and secure with hex flange nuts (Item 7).
3. Using the hitch as a template, drill one 17/32" hole thru each frame rail as shown.
4. Feed the fishwire through the hole in the hitch side plate ("A"), the drilled hole in frame rail and out the access hole in the frame rail.
5. Thread spacer (Item 2) onto fishwire, attach to carriage bolt (Item 1). Pull fasteners through slot & into position as shown.
6. Loosely install hex flange nuts (Item 3) onto carriage bolts.
7. Torque all 3/8" fasteners to 30 lb-ft and torque all 1/2" fasteners to 75 lb-ft.

PERIODICALLY CHECK THIS RECEIVER HITCH TO ENSURE THAT ALL FASTENERS ARE TIGHT AND THAT ALL STRUCTURAL COMPONENTS ARE SOUND.

Curt Manufacturing Inc., warrants this product to be free of defects in material and/or workmanship at the time of retail purchase by the original purchaser. If the product is found to be defective, Curt Manufacturing Inc., may repair or replace the product, at their option, when the product is returned, prepaid, with proof of purchase. Alteration to, misuse of, or improper installation of this product voids the warranty. Curt Manufacturing Inc.'s liability is limited to repair or replacement of products found to be defective, and specifically excludes liability for incidental or consequential loss or damage.