

12093**MAZDA CX-7****8/27/2008**

GROSS LOAD CAPACITY WHEN USED AS A WEIGHT CARRYING HITCH: 3,500 LBS. TRAILER WEIGHT & 300 LBS. TONGUE WEIGHT.
 DO NOT EXCEED VEHICLE MANUFACTURER'S RECOMMENDED TOWING CAPACITY.

Parts List			
ITEM	QTY	PART NUMBER	DESCRIPTION
1	6	1/2-13 x 1 1/2	CARRIAGE BOLT
2	6	CM-SP40	.188 x 1.00 x 3.00" SQ. HOLE SPACER
3	6	HFN 1213	HEX FLANGE NUT
4	1	1_2 FISHWIRE	1/2" FISHWIRE

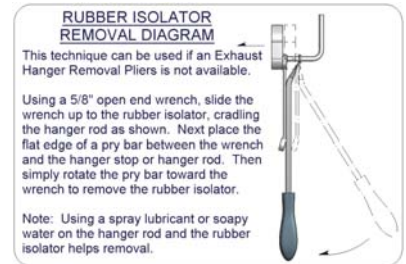
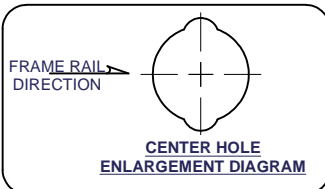
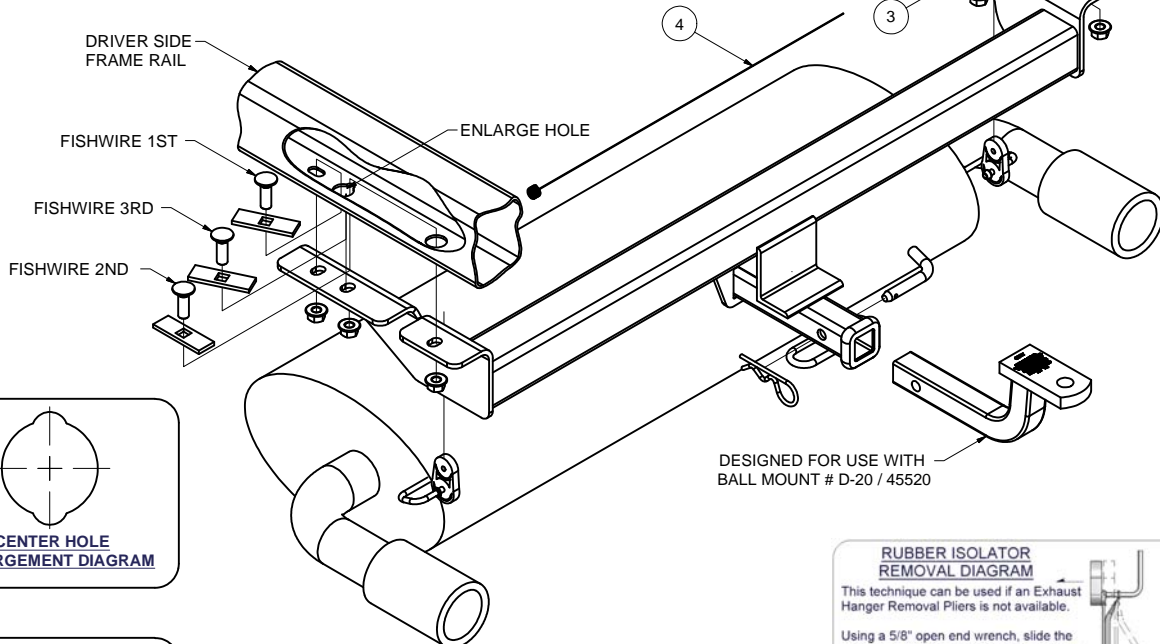
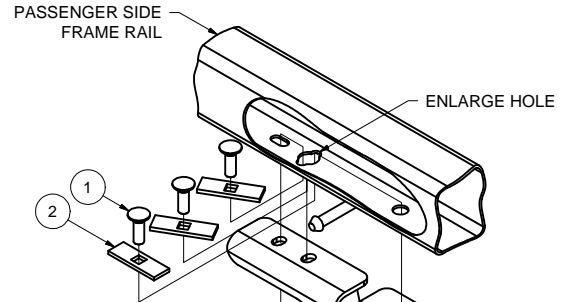
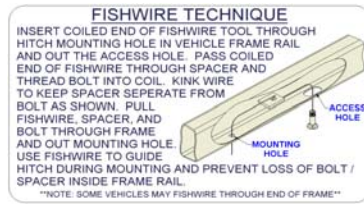
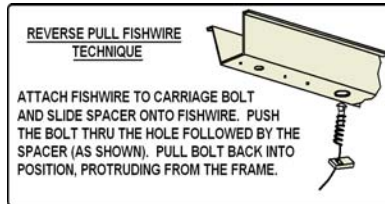

HITCH WEIGHT: 43 LBS.
 INSTALL TIME: 30 MINUTES
 INSTALL NOTES:
 - LOWER EXHAUST
 - ENLARGE HOLES (2)
 - FISHWIRE HARDWARE

INSTALLATION STEPS

- 1) Lower exhaust by removing (4) rubber isolators. (See Rubber Isolator Removal Diagram.)
- 2) Enlarge center holes to allow spacer and carriage bolts to pass through. (See Hole Enlargement Diagram.)
- 3) Fishwire 1st and 2nd carriage bolts and spacers into position as shown. (Both sides; See Fishwire Technique.)
- 4) Reverse fishwire 3rd carriage bolt and spacer into center hole. (Both sides; See Reverse Pull Fishwire Technique.)
- 5) Raise hitch into position and attach using the hex flange nuts.
- 6) Torque all 1/2" hardware to 75 lb-ft.
- 7) Install rubber exhaust isolators removed in Step 1.

PERIODICALLY CHECK THIS RECEIVER HITCH TO ENSURE THAT ALL FASTENERS ARE TIGHT AND THAT ALL STRUCTURAL COMPONENTS ARE SOUND.

Curt Manufacturing Inc., warrants this product to be free of defects in material and/or workmanship at the time of retail purchase by the original purchaser. If the product is found to be defective, Curt Manufacturing Inc., may repair or replace the product, at their option, when the product is returned, prepaid, with proof of purchase. Alteration to, misuse of, or improper installation of this product voids the warranty. Curt Manufacturing Inc.'s liability is limited to repair or replacement of products found to be defective, and specifically excludes liability for incidental or consequential loss or damage.