

12110**TOYOTA CAMRY SOLARA**

4/8/2009

GROSS LOAD CAPACITY WHEN USED AS A WEIGHT CARRYING HITCH: 3,500 LBS. TRAILER WEIGHT & 300 LBS. TONGUE WEIGHT.
 DO NOT EXCEED VEHICLE MANUFACTURER'S RECOMMENDED TOWING CAPACITY.

Parts List			
ITEM	QTY	PART NUMBER	DESCRIPTION
1	5	M10 - 1.25 x 30	HEX BOLT
2	5	3/8"	CONICAL TOOTHED WASHER

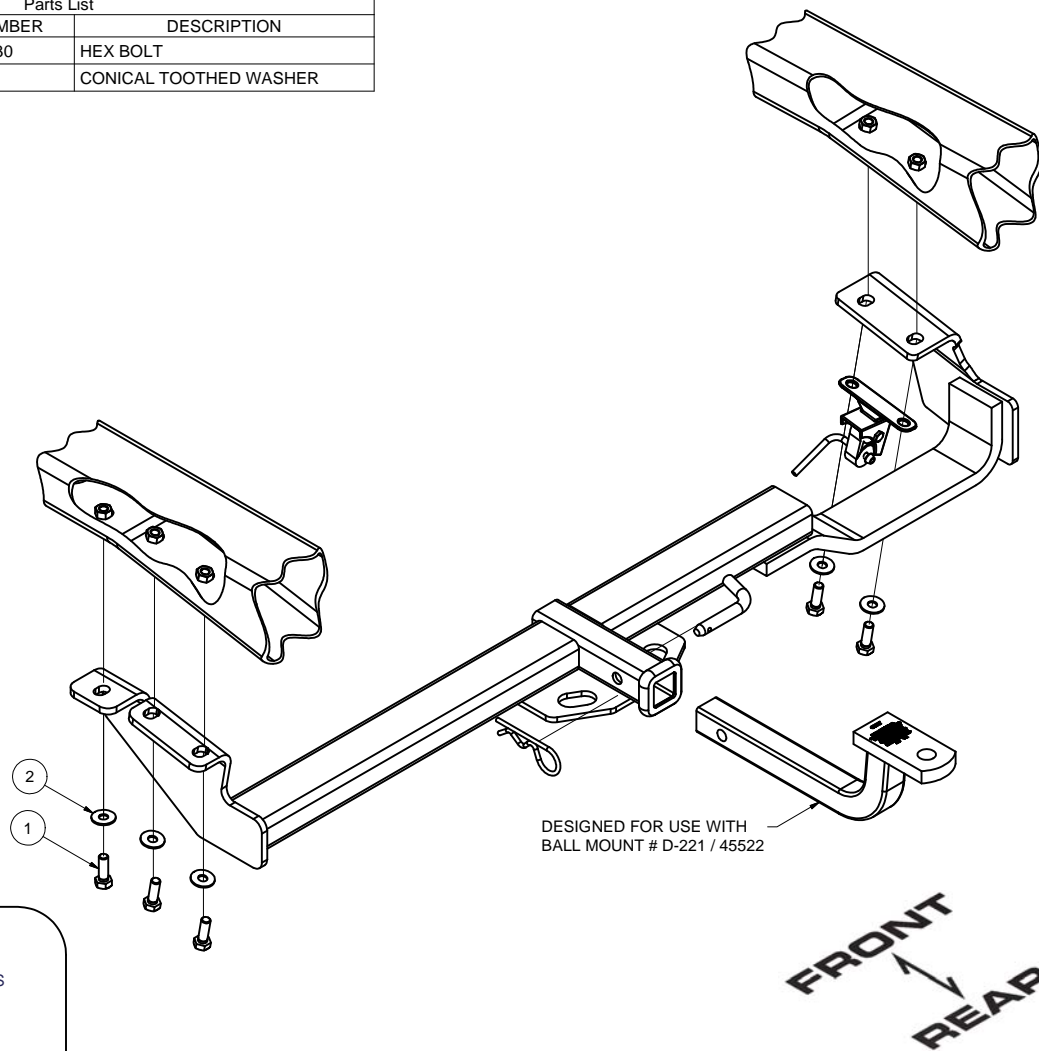

HITCH WEIGHT: 40 LBS.
 INSTALL TIME: 45 MINUTES
 INSTALL NOTES:
NO DRILLING REQUIRED

INSTALLATION STEPS

1. If present, remove the tie down brackets and bolts from each side of the vehicle's frame rails. Return these brackets and fasteners to the vehicle's owner.

NOTES: On vehicles with exhaust hanger bracket welded to passenger's side tie down bracket, the tie-down / exhaust hanger will be reattached with the hitch in step #3.

2. Remove the exhaust hanger bolted to the bottom of the frame rail on the passenger side. Return fasteners to the vehicle's owner. There is no need to remove the exhaust hanger from the rubber isolator.
3. Raise the hitch into position and install (5) 10mm bolts and conical toothed washers as shown. Install the bolts and conical toothed washers through the exhaust hanger bracket on the passenger's side frame rail as shown.
4. Torque all 10mm fasteners to 37 lb-ft.

PERIODICALLY CHECK THIS RECEIVER HITCH TO ENSURE THAT ALL FASTENERS ARE TIGHT AND THAT ALL STRUCTURAL COMPONENTS ARE SOUND.

Curt Manufacturing Inc., warrants this product to be free of defects in material and/or workmanship at the time of retail purchase by the original purchaser. If the product is found to be defective, Curt Manufacturing Inc., may repair or replace the product, at their option, when the product is returned, prepaid, with proof of purchase. Alteration to, misuse of, or improper installation of this product voids the warranty. Curt Manufacturing Inc.'s liability is limited to repair or replacement of products found to be defective, and specifically excludes liability for incidental or consequential loss or damage.

6/12/06