

12112

# MAZDA CX-9

3/29/2013

GROSS LOAD CAPACITY WHEN USED AS A WEIGHT CARRYING HITCH: 3500 LBS. TRAILER WEIGHT & 350 LBS. TONGUE WEIGHT.

**\*\*\*DO NOT EXCEED VEHICLE MANUFACTURER'S RECOMMENDED TOWING CAPACITY.\*\*\***

WARNING: ALL NON-TRAILER LOADS APPLIED TO THIS PRODUCT MUST BE SUPPORTED BY 18050 STABILIZING STRAPS.

**\*\* FAILURE TO PROPERLY SUPPORT NON-TRAILER LOADS WILL VOID PRODUCT WARRANTY\*\***

HAVING INSTALLATION QUESTIONS? CALL TECHNICAL SUPPORT AT 1-800-798-0813

Parts List			
ITEM	QTY	PART NUMBER	DESCRIPTION
1	6	M12-1.25 x 30mm	HEX BOLT
2	6	1/2"	CONICAL TOOTHED WASHER
3	2	M8 - 1.25 x 30 HEX BOLT	HEX HEAD BOLT
4	2	3/8"	CONICAL TOOTHED WASHER

TOOLS REQUIRED
19mm SOCKET
13mm SOCKET
TORQUE WRENCH
RATCHET

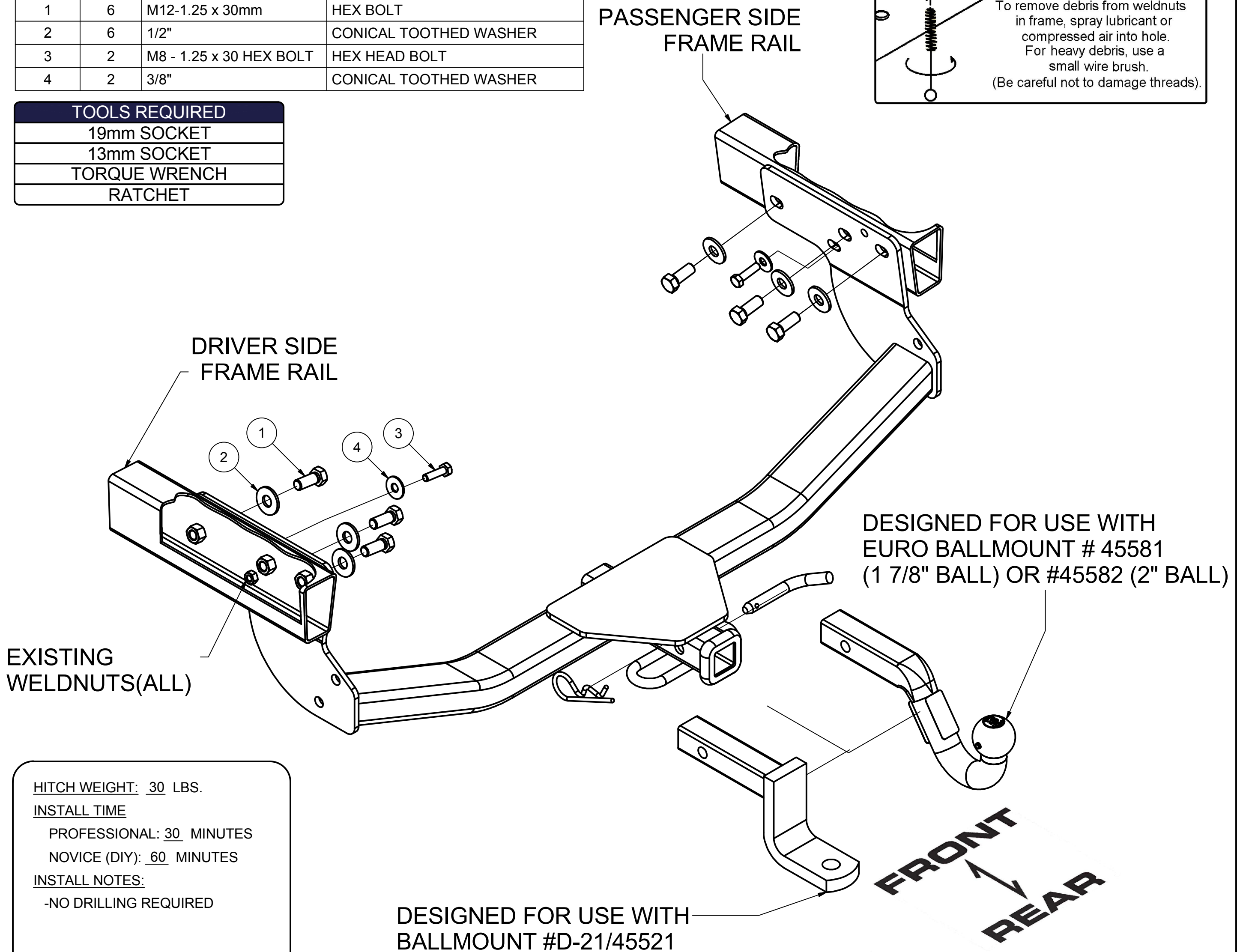
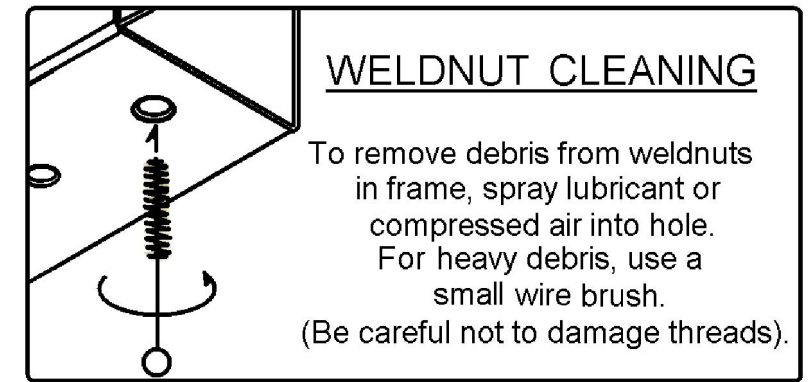

HITCH WEIGHT: 30 LBS.  
 INSTALL TIME  
 PROFESSIONAL: 30 MINUTES  
 NOVICE (DIY): 60 MINUTES  
 INSTALL NOTES:  
 -NO DRILLING REQUIRED

DESIGNED FOR USE WITH BALLMOUNT #D-21/45521

- ### INSTALLATION STEPS
- 1) Raise hitch into position.
  - 2) Attach, finger tight, with (3) M12 hex bolts and 1/2" conical toothed washers and (1) M8 hex bolt with a 3/8" conical washer per side.
  - 3) Torque all M12 hardware to 86 ft.-lb. and all M8 hardware to 23 ft.-lb.
- PERIODICALLY CHECK THIS RECEIVER HITCH TO ENSURE THAT ALL FASTENERS ARE TIGHT AND THAT ALL STRUCTURAL COMPONENTS ARE SOUND.**

Curt Manufacturing LLC., warrants this product to be free of defects in material and/or workmanship at the time of retail purchase by the original purchaser. If the product is found to be defective, Curt Manufacturing LLC., may repair or replace the product, at their option, when the product is returned, prepaid, with proof of purchase. Alteration to, misuse of, or improper installation of this product voids the warranty. Curt Manufacturing LLC.'s liability is limited to repair or replacement of products found to be defective, and specifically excludes liability for incidental or consequential loss or damage.