

12234**PONTIAC VIBE / TOYOTA MATRIX****3/18/2011**

GROSS LOAD CAPACITY WHEN USED AS A WEIGHT CARRYING HITCH: 2,000 LBS. TRAILER WEIGHT & 200 LBS. TONGUE WEIGHT.
 DO NOT EXCEED VEHICLE MANUFACTURER'S RECOMMENDED TOWING CAPACITY.

Parts List			
ITEM	QTY	PART NUMBER	DESCRIPTION
1	4	M12-1.25 x 30mm	HEX BOLT
2	4	1/2"	CONICAL TOOTHED WASHER

TOOLS REQUIRED

RATCHET

10" EXTENSION

19mm SOCKET

TORQUE WRENCH

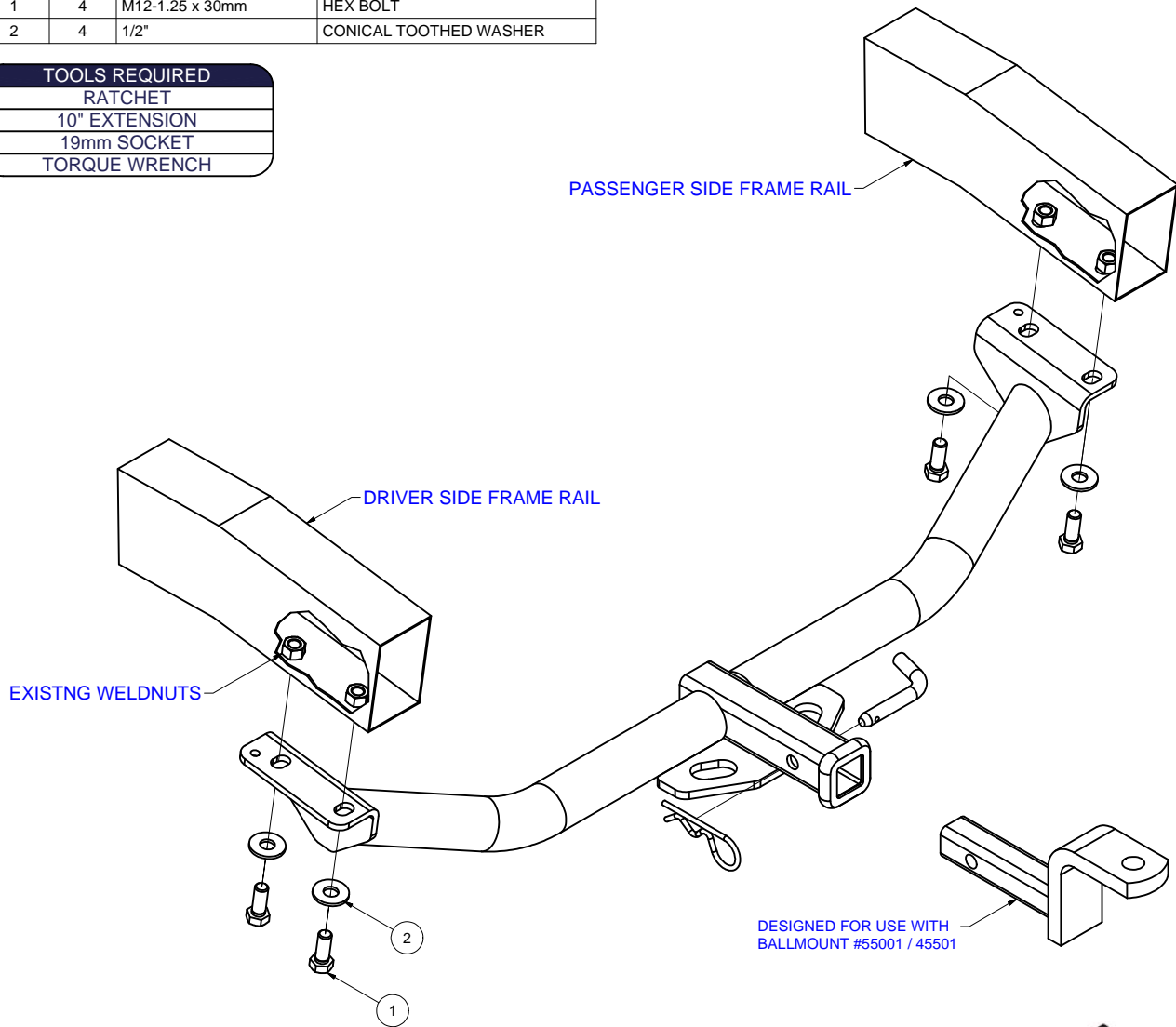
HITCH WEIGHT: 21 LBS.INSTALL TIME: 30 MINUTES

INSTALL NOTES:

- NO DRILLING REQUIRED
- HEAT SHIELD MODIFICATION MAY BE REQUIRED

INSTALLATION STEPS

Note: On 2003 - 2008 Toyota Matrix XRS and XR Sport models there is lower valance that must be trimmed for hitch installation.

1. Raise hitch into position, aligning slots in side plates with existing weldnuts in frame rails.
2. Install hex bolts and conical toothed washers.
3. Torque bolts to 65 lb-ft.

PERIODICALLY CHECK THIS RECEIVER HITCH TO ENSURE THAT ALL FASTENERS ARE TIGHT AND THAT ALL STRUCTURAL COMPONENTS ARE SOUND.

Curt Manufacturing Inc., warrants this product to be free of defects in material and/or workmanship at the time of retail purchase by the original purchaser. If the product is found to be defective, Curt Manufacturing Inc., may repair or replace the product, at their option, when the product is returned, prepaid, with proof of purchase. Alteration to, misuse of, or improper installation of this product voids the warranty. Curt Manufacturing Inc.'s liability is limited to repair or replacement of products found to be defective, and specifically excludes liability for incidental or consequential loss or damage.