

12239

05-CURRENT BUICK ALLURE
97-06 BUICK CENTURY PASSENGER05-CURRENT BUICK LA CROSSE
98-02 OLDSMOBILE INTRIGUE

3/18/2011

GROSS LOAD CAPACITY WHEN USED AS A WEIGHT CARRYING HITCH: 3500 LBS. TRAILER WEIGHT & 350 LBS. TONGUE WEIGHT.

DO NOT EXCEED VEHICLE MANUFACTURER'S RECOMMENDED TOWING CAPACITY.

WARNING: ALL NON-TRAILER LOADS APPLIED TO THIS PRODUCT MUST BE SUPPORTED BY AUXILIARY STABILIZING STRAPS.

** FAILURE TO PROPERLY SUPPORT NON-TRAILER LOADS WILL VOID PRODUCT WARRANTY**

HAVING INSTALLATION QUESTIONS? CALL TECHNICAL SUPPORT AT 1-800-798-0813

Parts List				
ITEM	QTY	PART NUMBER	DESCRIPTION	
1	1	1/2"	FISHWIRE TOOL	
2	4	CM-SP1	.250 x 1.50 x 2.00" SQUARE HOLE SPACER	
3	4	1/2-13 x 1 1/4	CARRIAGE BOLT	
4	4	HFN 1213	HEX FLANGE NUT	
5	4	FW12	FW, 12, ZP	
6	2	1/2"	LOCK WASHER	
7	2	1/2-13 x 1 1/4	HEX BOLT	
8	2	1/2-13	HANDLE NUT	
9	4	CM-SP35	.188 x 1.00 x 2.38" ROUND HOLE SPACER	
10	4	7/16-14	HEX FLANGE NUT	
11	4	7_16 - 14 x 1	HEX BOLT	

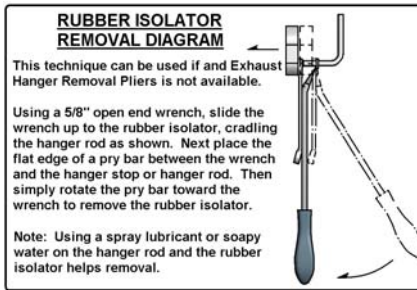
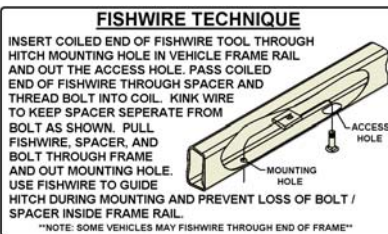
FRONT
↓
REAR

USE THIS HOLE ON CENTURY & INTRIGUE

USE THIS HOLE ON LACROSSE

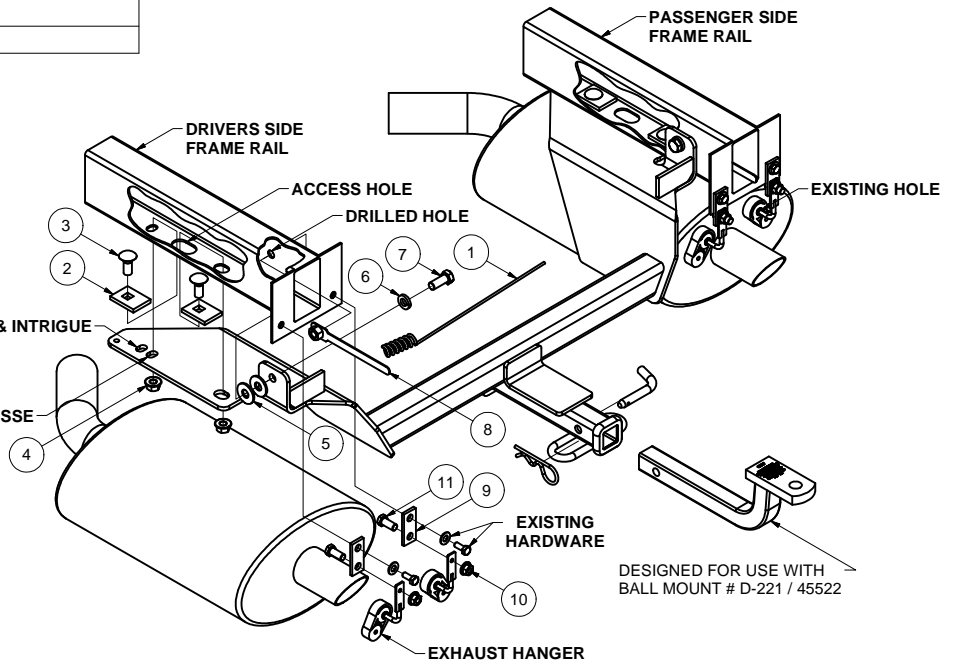

HITCH WEIGHT: 35 LBS.

INSTALL TIME

PROFESSIONAL: 45 MINUTES

NOVICE (DIY): 90 MINUTES

INSTALL NOTES:

- DRILLING REQUIRED
- FISHWIRE FASTENERS
- LOWER EXHAUST
- MAY REQUIRE FASCIA TRIMMING ON BUICK LA CROSSE "SUPER"

INSTALLATION STEPS

- 1) Detach (4) rear rubber exhaust hangers from frame and lower exhaust system.
- 2) Fishwire carriage bolts and spacers through access holes in frame rails, as shown.
- 3) Raise hitch into position and secure with flange nuts, finger tighten.
- 4) Using hitch as a template, drill (2) 1/2" holes in the side of the frame rails.
- 5) Check side to side clearance between hitch and frame. Install 1/2" washers between hitch and frame as necessary to eliminate gap. Insert 1/2" hex bolt and lock washer through side of frame rail and secure with handle nut inserted through end of frame rails.
- 6) Reinstall exhaust hangers removed in step 1. **(Note: For Buick LaCrosse use 7/16" hex bolts, spacers, and flange nuts to lower exhaust system as shown.)**
- 7) Torque all 1/2" fasteners to 75 lb-ft and all 7/16" fasteners to 50 lb-ft.

PERIODICALLY CHECK THIS RECEIVER HITCH TO ENSURE THAT ALL FASTENERS ARE TIGHT AND THAT ALL STRUCTURAL COMPONENTS ARE SOUND.

Curt Manufacturing Inc., warrants this product to be free of defects in material and/or workmanship at the time of retail purchase by the original purchaser. If the product is found to be defective, Curt Manufacturing Inc., may repair or replace the product, at their option, when the product is returned, prepaid, with proof of purchase. Alteration to, misuse of, or improper installation of this product voids the warranty. Curt Manufacturing Inc.'s liability is limited to repair or replacement of products found to be defective, and specifically excludes liability for incidental or consequential loss or damage.

36239