

12240**CHRYSLER 300 LIMITED / 300C
DODGE MAGNUM / SRT8 / CHARGER/ CHALLENGER****3/18/2011****GROSS LOAD CAPACITY WHEN USED AS A WEIGHT CARRYING HITCH: 3500 LBS. TRAILER WEIGHT & 350 LBS. TONGUE WEIGHT.**

DO NOT EXCEED VEHICLE MANUFACTURER'S RECOMMENDED TOWING CAPACITY.

WARNING: ALL NON-TRAILER LOADS APPLIED TO THIS PRODUCT MUST BE SUPPORTED BY AUXILIARY STABILIZING STRAPS.

** FAILURE TO PROPERLY SUPPORT NON-TRAILER LOADS WILL VOID PRODUCT WARRANTY**

HAVING INSTALLATION QUESTIONS? CALL TECHNICAL SUPPORT AT 1-800-798-0813

Parts List			
ITEM	QTY	PART NUMBER	DESCRIPTION
1	1	1/2"	FISHWIRE TOOL
2	3	1/2-13 x 1 3/4	CARRIAGE BOLT
3	3	CM-SP40	.188 x 1.00 x 3.00" SQUARE HOLE SPACER
4	3	HFN 1213	HEX FLANGE NUT
5	3	M12-1.75 x 40mm	HEX BOLT
6	3	1/2"	CONICAL TOOTHED WASHER

FISHWIRE TECHNIQUE

INSERT COILED END OF FISHWIRE TOOL THROUGH HITCH MOUNTING HOLE IN VEHICLE FRAME RAIL AND OUT THE ACCESS HOLE. PASS COILED END OF FISHWIRE THROUGH SPACER AND THREAD BOLT INTO COIL. KINK WIRE TO KEEP SPACER SEPERATE FROM BOLT AS SHOWN. PULL FISHWIRE, SPACER, AND BOLT THROUGH FRAME AND OUT MOUNTING HOLE. USE FISHWIRE TO GUIDE HITCH DURING MOUNTING AND PREVENT LOSS OF BOLT / SPACER INSIDE FRAME RAIL.

NOTE: SOME VEHICLES MAY FISHWIRE THROUGH END OF FRAME

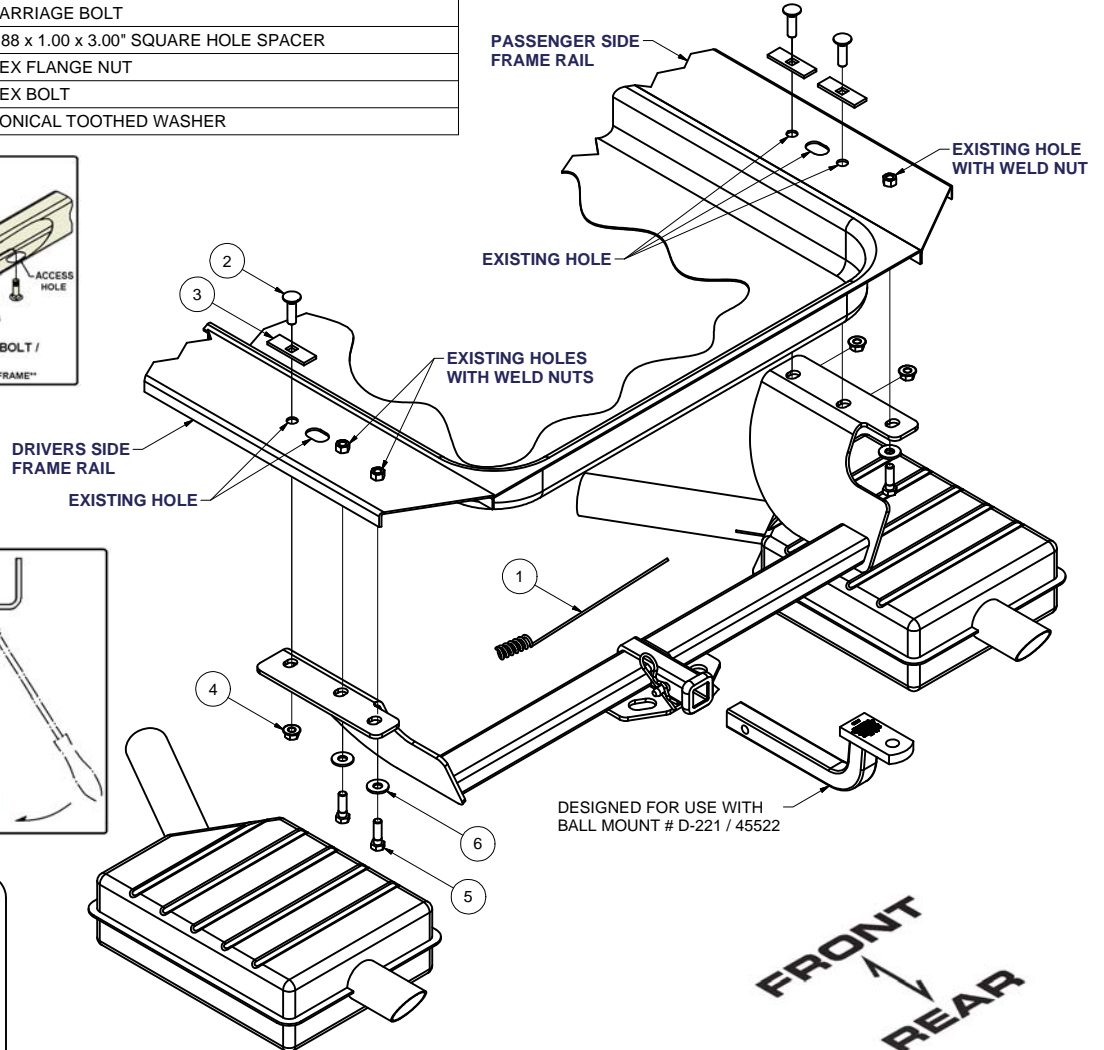
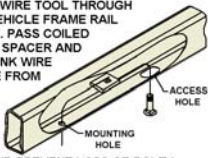
**RUBBER ISOLATOR REMOVAL DIAGRAM**

This technique can be used if and Exhaust Hanger Removal Pliers is not available.

Using a 5/8" open end wrench, slide the wrench up to the rubber isolator, cradling the hanger rod as shown. Next place the flat edge of a pry bar between the wrench and the hanger stop or hanger rod. Then simply rotate the pry bar toward the wrench to remove the rubber isolator.

Note: Using a spray lubricant or soapy water on the hanger rod and the rubber isolator helps removal.

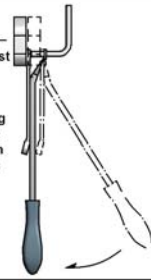

HITCH WEIGHT: 30 LBS.

INSTALL TIME

PROFESSIONAL: 40 MINUTES

NOVICE (DIY): 80 MINUTES

INSTALL NOTES:

NO DRILLING REQUIRED

FISHWIRE FASTENERS

INSTALLATION STEPS

- 1) Lower exhaust by removing the (2) hangers and (1) rubber mount on the 300 limited.
(Note the 300C and Dodge Magnum will have (4) hangers and (2) rubber mounts for dual exhaust.)
- 2) Fishwire 1/2" carriage bolts and spacer blocks through existing holes in the frame as shown.
- 3) Slide hitch over muffler(s) and into position over the 1/2" carriage bolts. Secure with flange nuts, finger tight only.
- 4) Install 12mm hex bolts and conical washers in remaining holes, finger tighten.
- 5) Torque all 1/2" fasteners to 75 lb-ft, torque all 12mm fasteners to 60 lb-ft.
- 6) Reinstall exhaust hangers removed in step (1).

PERIODICALLY CHECK THIS RECEIVER HITCH TO ENSURE THAT ALL FASTENERS ARE TIGHT AND THAT ALL STRUCTURAL COMPONENTS ARE SOUND.

Curt Manufacturing Inc., warrants this product to be free of defects in material and/or workmanship at the time of retail purchase by the original purchaser. If the product is found to be defective, Curt Manufacturing Inc., may repair or replace the product, at their option, when the product is returned, prepaid, with proof of purchase. Alteration to, misuse of, or improper installation of this product voids the warranty. Curt Manufacturing Inc.'s liability is limited to repair or replacement of products found to be defective, and specifically excludes liability for incidental or consequential loss or damage.