

12253

2000-2006 LINCOLN LS

1/4/2013

GROSS LOAD CAPACITY WHEN USED AS A WEIGHT CARRYING HITCH: 3500 LBS. TRAILER WEIGHT & 300 LBS. TONGUE WEIGHT.

\*\*\*DO NOT EXCEED VEHICLE MANUFACTURER'S RECOMMENDED TOWING CAPACITY.\*\*\*

WARNING: ALL NON-TRAILER LOADS APPLIED TO THIS PRODUCT MUST BE SUPPORTED BY AUXILIARY STABILIZING STRAPS.

\*\* FAILURE TO PROPERLY SUPPORT NON-TRAILER LOADS WILL VOID PRODUCT WARRANTY\*\*

HAVING INSTALLATION QUESTIONS? CALL TECHNICAL SUPPORT AT 1-800-798-0813

Parts List			
ITEM	QTY	PART NUMBER	DESCRIPTION
1	4	7/16-14	HEX FLANGE NUT
2	4	CM-SP11	.250 x 1.00 x 2.50" SQUARE HOLE SPACER
3	4	7/16-14 x 1 1/2	CARRIAGE BOLT

**FISHWIRE TECHNIQUE**

INSERT COILED END OF FISHWIRE TOOL THROUGH HITCH MOUNTING HOLE IN VEHICLE FRAME RAIL AND OUT THE ACCESS HOLE. PASS COILED END OF FISHWIRE THROUGH SPACER AND THREAD BOLT INTO COIL. KINK WIRE TO KEEP SPACER SEPERATE FROM BOLT AS SHOWN. PULL FISHWIRE, SPACER, AND BOLT THROUGH FRAME AND OUT MOUNTING HOLE. USE FISHWIRE TO GUIDE HITCH DURING MOUNTING AND PREVENT LOSS OF BOLT / SPACER INSIDE FRAME RAIL.

\*NOTE: SOME VEHICLES MAY FISHWIRE THROUGH END OF FRAME\*

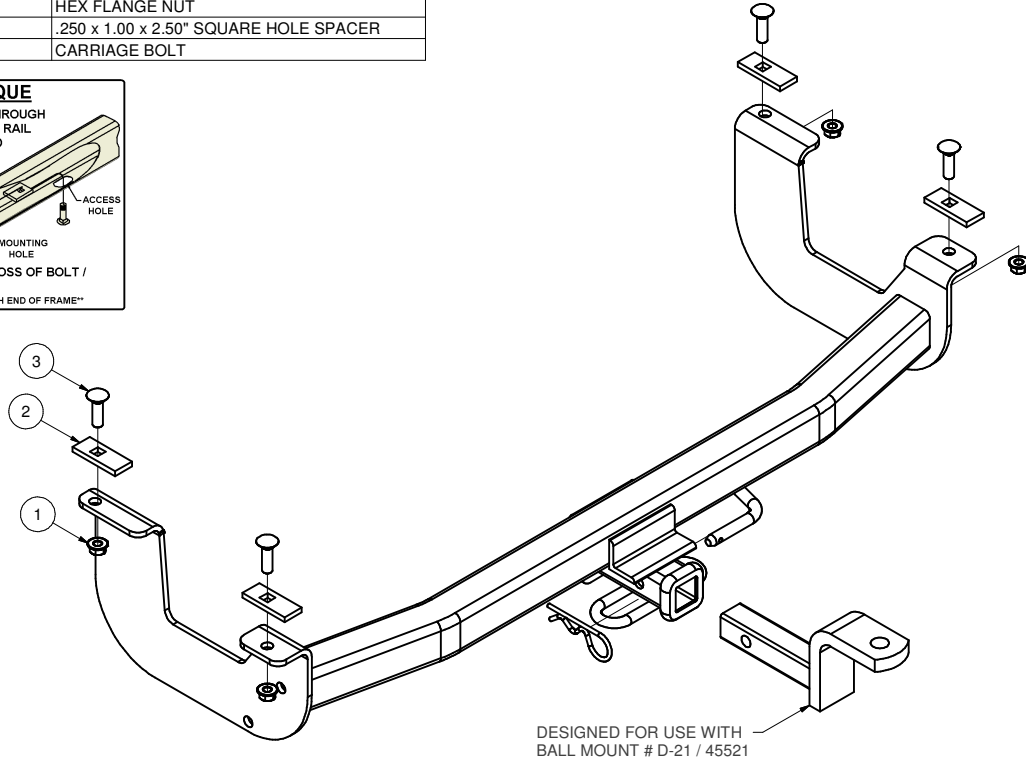

HITCH WEIGHT: 28 LBS.

**INSTALL TIME**

PROFESSIONAL: 30 MINUTES

NOVICE (DIY): 60 MINUTES

**INSTALL NOTES:**

-DRILLING REQUIRED

-FISHWIRE HARDWARE

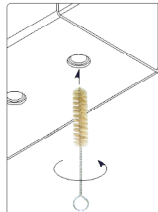

**WELDNUT CLEANING**

To remove debris from weldnuts in frame, spray lubricant or compressed air into hole. For heavy debris, use a small wire brush. (Be careful not to damage threads).

**FRONT**  
↑  
**REAR**

**INSTALLATION STEPS**

- 1) Disconnect the two fascia tabs holding the lower fascia to the trunk pan.
- 2) Fishwire the foreward fasteners in the frame rail.
- 3) Use the nylon washers between the spacers and the aluminum bumper.
- 4) Raise the hitch into position and attach with fasteners toward front of vehicle.
- 5) Using the hitch as a template, drill two 1/2" holes in the bumper.
- 6) Fishwire carriage bolts and spacers thru holes in bumper and install lock washers and nuts.
- 7) Reattach the lower fascia tabs with cable ties provided.
- 8) Torque all 7/16 hardware to 50 ft-lbs

**PERIODICALLY CHECK THIS RECEIVER HITCH TO ENSURE THAT ALL FASTENERS ARE TIGHT AND THAT ALL STRUCTURAL COMPONENTS ARE SOUND.**

Curt Manufacturing Inc., warrants this product to be free of defects in material and/or workmanship at the time of retail purchase by the original purchaser. If the product is found to be defective, Curt Manufacturing Inc., may repair or replace the product, at their option, when the product is returned, prepaid, with proof of purchase. Alteration, misuse of, or improper installation of this product voids the warranty. Curt Manufacturing Inc.'s liability is limited to repair or replacement of products found to be defective, and specifically excludes liability for incidental or consequential loss or damage.