

12264

DODGE GRAND CARAVAN SXT / CHRYSLER TOWN AND COUNTRY TOURING ALL STO & GO MODELS / VOLKSWAGEN ROUTAN S, SE, SEL / RAM CARGO VAN

4/27/2012

GROSS LOAD CAPACITY WHEN USED AS A WEIGHT CARRYING HITCH: 3,500 LBS. TRAILER WEIGHT & 350 LBS. TONGUE WEIGHT.

\*\*\*DO NOT EXCEED VEHICLE MANUFACTURER'S RECOMMENDED TOWING CAPACITY.\*\*\*

WARNING: ALL NON-TRAILER LOADS APPLIED TO THIS PRODUCT MUST BE SUPPORTED BY 18050 STABILIZING STRAPS.

\*\* FAILURE TO PROPERLY SUPPORT NON-TRAILER LOADS WILL VOID PRODUCT WARRANTY\*\*

HAVING INSTALLATION QUESTIONS? CALL TECHNICAL SUPPORT AT 1-800-798-0813

**TOOLS REQUIRED**

- 3/8" DRIVE RATCHET
- 18mm - 3/8 DRIVE SOCKET
- 15mm - 3/8" DRIVE SOCKET
- 13mm - 3/8" DRIVE SOCKET
- TORQUE WRENCH
- SCREW DRIVER / PUNCH

**\*\*CAUTION\*\***

DO NOT PINCH OR CRUSH AC LINES (IF PRESENT) WHEN INSTALLING HITCH

**\*\*\* USE EXISTING VEHICLE HARDWARE \*\*\***

\*\*\* BE SURE LEAVE BOLT ON PASSENGER SIDE TO HOLD BUMPER BEAM IN POSITION \*\*\*

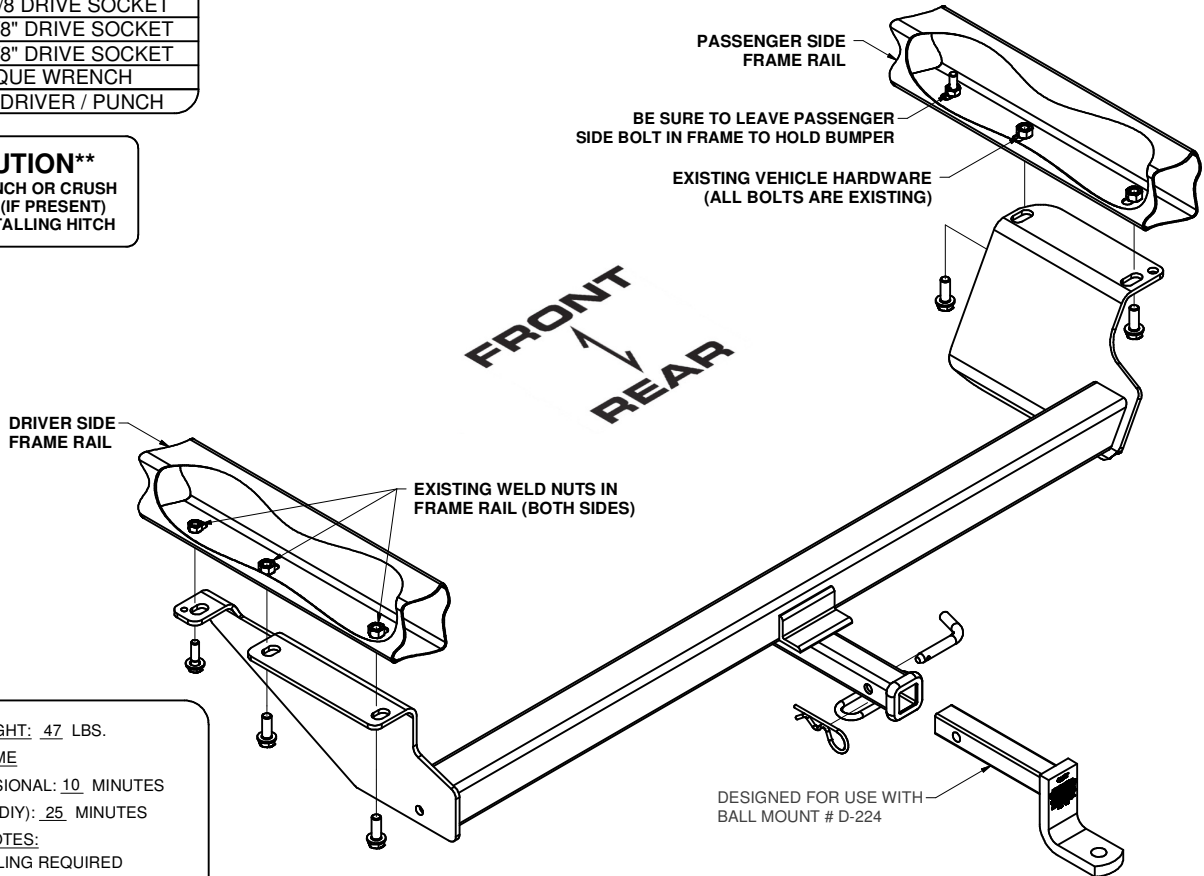

HITCH WEIGHT: 47 LBS.

**INSTALL TIME**

PROFESSIONAL: 10 MINUTES

NOVICE (DIY): 25 MINUTES

**INSTALL NOTES:**

- NO DRILLING REQUIRED
- USE EXISTING FASTENERS
- LOWER EXHAUST

**INSTALLATION STEPS**

- 1) Locate and remove the (2) bolts using a 15mm socket and (3) bolts using a 18mm socket bolts as shown above. Leave (1) 12mm bolt on passenger side of vehicle frame toward the front of vehicle that holds the bumper bracket to vehicle frame. Remove the bolt(s) holding the exhaust and muffler hanger(s). This will allow exhaust to drop down out of the way for hitch installation.
  - 2) Raise hitch into position against the bottom of vehicle frame and align holes in hitch frame brackets with the holes in vehicle frame. Be sure air conditioning (AC) lines are not pinched between hitch and frame rail (if AC lines are present).
  - 3) Mount hitch using existing 10mm and 12mm bolts, may need a punch or screw driver to align holes.
  - 4) Torque all 10mm fasteners to 53 lb-ft, and all 12mm fasteners to 73 lb-ft.
  - 5) Raise the muffler and install the supplied bolt and nut to hanger. Re-install any other exhaust bolts removed earlier in Step 1.
- NOTE:** Rotating exhaust hanger bracket before tightening will add clearance between side bracket and exhaust.

**PERIODICALLY CHECK THIS RECEIVER HITCH TO ENSURE THAT ALL FASTENERS ARE TIGHT AND THAT ALL STRUCTURAL COMPONENTS ARE SOUND.**

Curt Manufacturing Inc., warrants this product to be free of defects in material and/or workmanship at the time of retail purchase by the original purchaser. If the product is found to be defective, Curt Manufacturing Inc., may repair or replace the product, at their option, when the product is returned, prepaid, with proof of purchase. Alteration to, misuse of, or improper installation of this product voids the warranty. Curt Manufacturing Inc.'s liability is limited to repair or replacement of products found to be defective, and specifically excludes liability for incidental or consequential loss or damage.