

12270

# 90-04 SUBARU LEGACY SEDAN, 95-04 OUTBACK

4/11/2011

GROSS LOAD CAPACITY WHEN USED AS A WEIGHT CARRYING HITCH: 3500 LBS. TRAILER WEIGHT & 350 LBS. TONGUE WEIGHT.

\*\*\*DO NOT EXCEED VEHICLE MANUFACTURER'S RECOMMENDED TOWING CAPACITY.\*\*\*

**WARNING: ALL NON-TRAILER LOADS APPLIED TO THIS PRODUCT MUST BE SUPPORTED BY AUXILIARY STABILIZING STRAPS.**

\*\* FAILURE TO PROPERLY SUPPORT NON-TRAILER LOADS WILL VOID PRODUCT WARRANTY\*\*

**HAVING INSTALLATION QUESTIONS? CALL TECHNICAL SUPPORT AT 1-800-798-0813**

Parts List			
ITEM	QTY	PART NUMBER	DESCRIPTION
1	4	HFN 1213	HEX FLANGE NUT
2	2	1/2-13 x 1 3/4"	CARRIAGE BOLT
3	2	CM-SP6	.250 x 1.00 x 3.00" SQUARE HOLE SPACER
4	2	1/2-13 x 2"	HEX BOLT
5	4	CM-SP25	.250 x 1.38 x 1.50" ROUND HOLE SPACER
6	1	1/2"	FISHWIRE TOOL

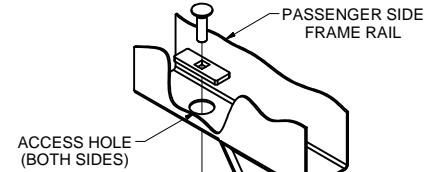
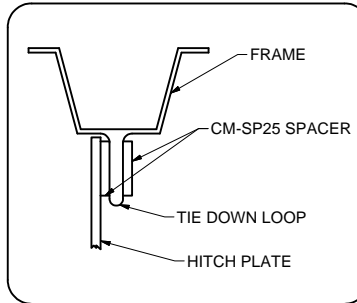

**REVERSE PULL FISHWIRE TECHNIQUE**

ATTACH FISHWIRE TO CARRIAGE BOLT AND SLIDE SPACER ONTO FISHWIRE. PUSH THE BOLT THRU THE HOLE FOLLOWED BY THE SPACER (AS SHOWN). PULL BOLT BACK INTO POSITION, PROTRUDING FROM THE FRAME.

**RUBBER ISOLATOR REMOVAL DIAGRAM**

This technique can be used if and Exhaust Hanger Removal Pliers is not available.

Using a 5/8" open end wrench, slide the wrench up to the rubber isolator, cradling the hanger rod as shown. Next place the flat edge of a pry bar between the wrench and the hanger stop or hanger rod. Then simply rotate the pry bar toward the wrench to remove the rubber isolator.

Note: Using a spray lubricant or soapy water on the hanger rod and the rubber isolator helps removal.

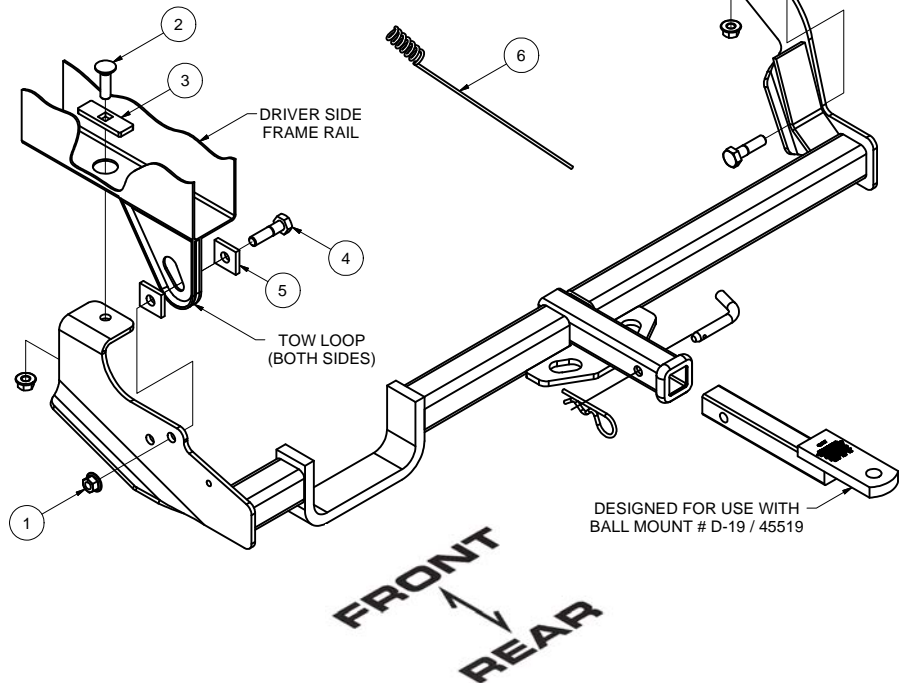

DESIGNED FOR USE WITH BALL MOUNT # D-19 / 45519

FRONT  
↑  
REAR

HITCH WEIGHT: 35 LBS.

INSTALL TIME

PROFESSIONAL: 30 MINUTES

NOVICE (DIY): 60 MINUTES

INSTALL NOTES:

- NO DRILLING REQUIRED

## INSTALLATION STEPS

1. If present, lower vapor canister (black plastic box) attached to the passenger side frame rail, canister will be reattached later in the installation. **Note:** It is not necessary to disconnect vapor hoses.
2. Remove the rear most exhaust hanger and move muffler to one side. (See Rubber Isolator Removal Diagram)
3. Remove the rubber plugs from the bottom of the frame rails. Reverse fishwire 1/2-13 x 1 3/4" carriage bolts and SP6 spacer into frame rails, as shown. (See Reverse Pull Fishwire Technique)
4. Raise hitch into position and check for alignment with tow loop holes. Secure hitch to the carriage bolts with 1/2" flange nuts. **Note:** When raising the hitch into position the driver side plate will be to the outside of the tow loop and the passenger side plate will be to the inside of the tow loop.
5. Align holes in the side plates with the tow loop holes and slide SP25 spacers and 1/2-13 x 2" hex bolts into position, as shown. Secure bolts using 1/2" flange nuts.
6. Torque all 1/2" hardware to 75 ft-lbs.
7. Reattach vapor canister and exhaust hanger lowered earlier in the installation.

PERIODICALLY CHECK THIS RECEIVER HITCH TO ENSURE THAT ALL FASTENERS ARE TIGHT AND THAT ALL STRUCTURAL COMPONENTS ARE SOUND.

Curt Manufacturing Inc., warrants this product to be free of defects in material and/or workmanship at the time of retail purchase by the original purchaser. If the product is found to be defective, Curt Manufacturing Inc., may repair or replace the product, at their option, when the product is returned, prepaid, with proof of purchase. Alteration to, misuse of, or improper installation of this product voids the warranty. Curt Manufacturing Inc.'s liability is limited to repair or replacement of products found to be defective, and specifically excludes liability for incidental or consequential loss or damage.