

12343 / 367343 TOYOTA CAMRY, CAMRY HYBRID (WILL NOT FIT SE) AND LEXUS ES 350

4/25/2011

GROSS LOAD CAPACITY WHEN USED AS A WEIGHT CARRYING HITCH: 3500 LBS. TRAILER WEIGHT & 350 LBS. TONGUE WEIGHT.
DO NOT EXCEED VEHICLE MANUFACTURER'S RECOMMENDED TOWING CAPACITY.

Parts List			
ITEM	QTY	PART NUMBER	DESCRIPTION
1	8	M10 - 1.25 x 30	HEX TAP BOLT
2	8	7/16"	CONICAL TOOTHED WASHER

TOOLS REQUIRED
10, 12, 14 AND 17mm SOCKETS
SWIVEL / KNUCKLE
10" EXTENSION
RATCHET
TORQUE WRENCH
FLAT SCREWDRIVER



TRIM
UNDERBODY PANEL TRIM DIAGRAM

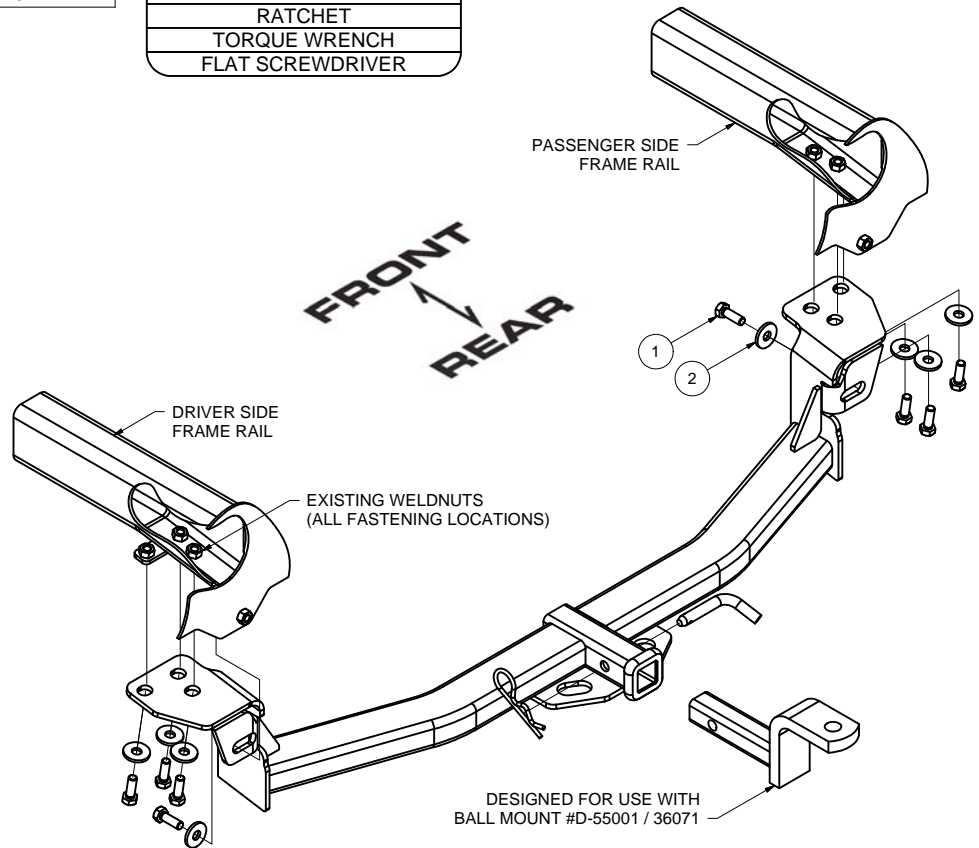

HITCH WEIGHT: 27 LBS.
INSTALL TIME: 45 MINUTES
INSTALL NOTES:
- NO DRILLING REQUIRED
- LOWER EXHAUST
- MAY REQUIRE FASCIA TRIMMING

INSTALLATION STEPS

1. Lower exhaust by removing (3) bolts in rearmost bracket and (2) rubber hangers forward of muffler. Support exhaust while installing hitch.
2. If present, remove the plastic fascia located under the trunk pan and passenger side frame rail. Fascia may be trimmed and fit around hitch or return plastic fascia and fasteners to owner. (See Fascia Trim Detail)
3. Remove driver and / or passenger side tow brackets (3 bolts) if present. Return the brackets and bolts to the customer.
4. Raise hitch into position, loosely install hitch using supplied M10 hex bolts and washers into horizontal holes as shown.
5. Raise exhaust and sandwich the hitch between the frame rail and exhaust hanger bracket. Install remaining (6) M10 hex bolts and washers, securing the hitch and exhaust to the frame rail.
6. Torque all M10 fasteners to 37 lb-ft.
7. If present, trim fascia and reinstall on vehicle. (See Fascia Trim Detail)

PERIODICALLY CHECK THIS RECEIVER HITCH TO ENSURE THAT ALL FASTENERS ARE TIGHT AND THAT ALL STRUCTURAL COMPONENTS ARE SOUND.

Curt Manufacturing Inc., warrants this product to be free of defects in material and/or workmanship at the time of retail purchase by the original purchaser. If the product is found to be defective, Curt Manufacturing Inc., may repair or replace the product, at their option, when the product is returned, prepaid, with proof of purchase. Alteration to, misuse of, or improper installation of this product voids the warranty. Curt Manufacturing Inc.'s liability is limited to repair or replacement of products found to be defective, and specifically excludes liability for incidental or consequential loss or damage.