

13085 / 75055**94-03 FORD WINDSTAR VAN****10/4/2011**

GROSS LOAD CAPACITY WHEN USED AS A WEIGHT CARRYING HITCH: 4000 LBS. TRAILER WEIGHT & 400 LBS. TONGUE WEIGHT.
 GROSS LOAD CAPACITY WHEN USED AS A WEIGHT DISTRIBUTION HITCH: 6000 LBS. TRAILER WEIGHT & 600 LBS. TONGUE WEIGHT

DO NOT EXCEED VEHICLE MANUFACTURER'S RECOMMENDED TOWING CAPACITY.

Parts List			
ITEM	QTY	PART NUMBER	DESCRIPTION
1	1	1/2"	FISHWIRE TOOL
2	6	CM-SP10	.250 x 1.00 x 2.50" SQUARE HOLE SPACER
3	6	1/2-13 x 1 3/4	CARRIAGE BOLT
4	6	HFN 1213	HEX FLANGE NUT

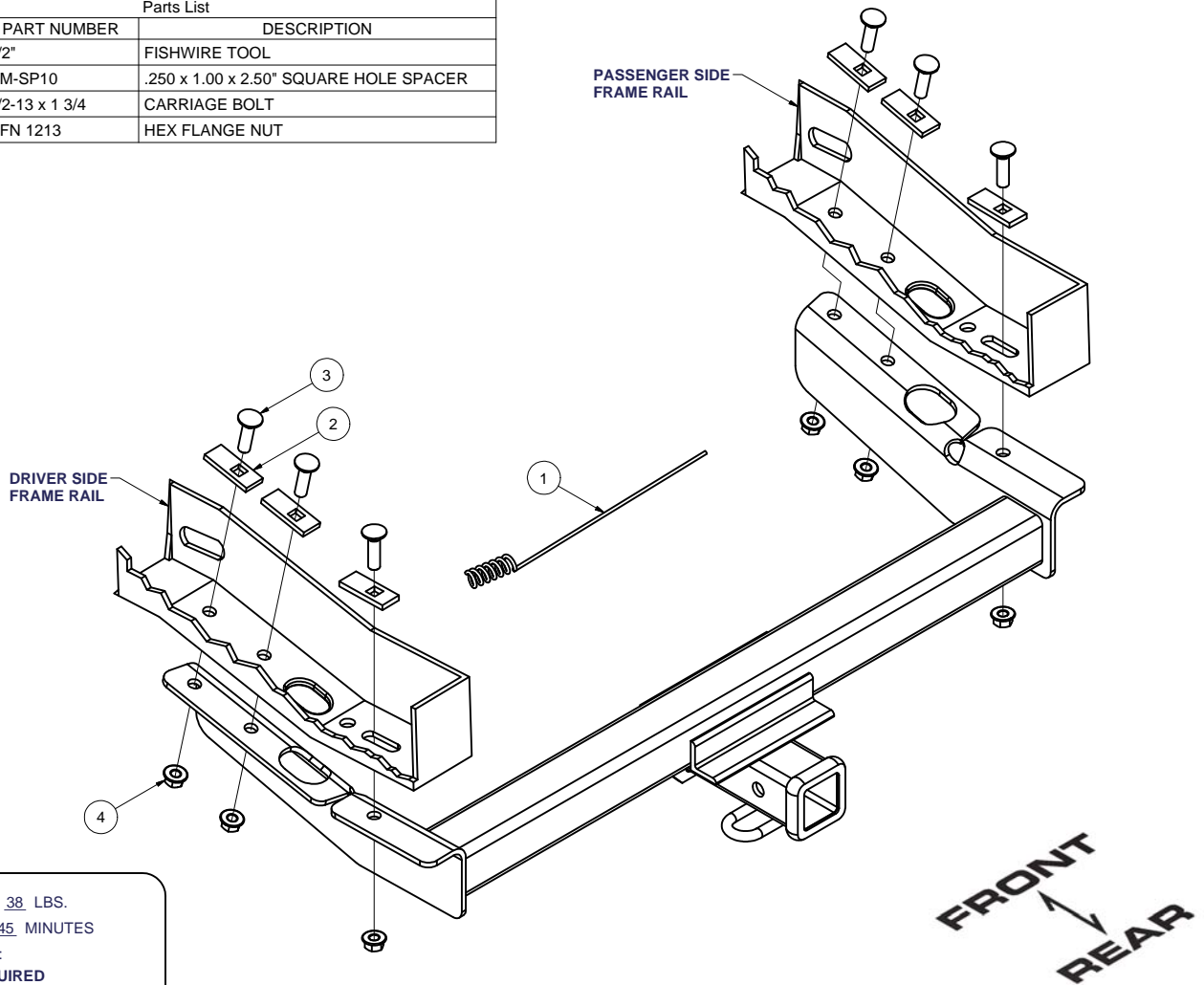

HITCH WEIGHT: 38 LBS.
 INSTALL TIME: 45 MINUTES
 INSTALL NOTES:
 - DRILLING REQUIRED
 - MUST FISHWIRE FASTENERS

INSTALLATION STEPS

- 1) Fishwire a square hole spacer and carriage bolt through the existing frame slot and down to existing rearward attachment slot as shown. (both sides)**
- 2) Raise hitch into position and fasten with 1/2" flange nuts provided.**
- 3) Using the hitch as a template drill two 1/2" holes per side for additional mounting hardware.**
- 4) Fishwire square hole spacers and bolts to the drilled locations.**
- 5) Attach a flange nut to each bolt and torque all fasteners to 75 lb-ft.**

PERIODICALLY CHECK THIS RECEIVER HITCH TO ENSURE THAT ALL FASTENERS ARE TIGHT AND THAT ALL STRUCTURAL COMPONENTS ARE SOUND.

Curt Manufacturing Inc., warrants this product to be free of defects in material and/or workmanship at the time of retail purchase by the original purchaser. If the product is found to be defective, Curt Manufacturing Inc., may repair or replace the product, at their option, when the product is returned, prepaid, with proof of purchase. Alteration to, misuse of, or improper installation of this product voids the warranty. Curt Manufacturing Inc.'s liability is limited to repair or replacement of products found to be defective, and specifically excludes liability for incidental or consequential loss or damage.