

# 13086 / 757202 84-95 TOYOTA PICKUP (EXCEPT T-100 & TACOMA)

11/30/2010

GROSS LOAD CAPACITY WHEN USED AS A WEIGHT CARRYING HITCH: 5,000 LBS. TRAILER WEIGHT & 500 LBS. TONGUE WEIGHT.  
 GROSS LOAD CAPACITY WHEN USED AS A WEIGHT DISTRIBUTION HITCH: 6,000 LBS. TRAILER WEIGHT & 600 LBS. TONGUE WEIGHT  
 \*\*\*DO NOT EXCEED VEHICLE MANUFACTURER'S RECOMMENDED TOWING CAPACITY.\*\*\*

| Parts List |     |               |  |  |
|------------|-----|---------------|--|--|
| ITEM       | QTY | PART NUMBER   | DESCRIPTION                            |  |
| 1          | 4   | CM-SP4        | .250 x 1.50 x 3.00" SQUARE HOLE SPACER |  |
| 2          | 2   | 1/2-13 x 4    | CARRIAGE BOLT                          |  |
| 3          | 12  | HFN 1213      | HEX FLANGE NUT                         |  |
| 4          | 6   | 1/2 - 13 x 2" | CARRIAGE BOLT                          |  |
| 5          | 4   | CM-SP1        | .250 x 1.50 x 2.00" SQUARE HOLE SPACER |  |
| 6          | 4   | 1/2-13 x 2"   | HEX BOLT                               |  |
| 7          | 8   | 7/16-14 x 2   | CARRIAGE BOLT                          |  |
| 8          | 8   | 7/16-14       | HEX FLANGE NUT                         |  |

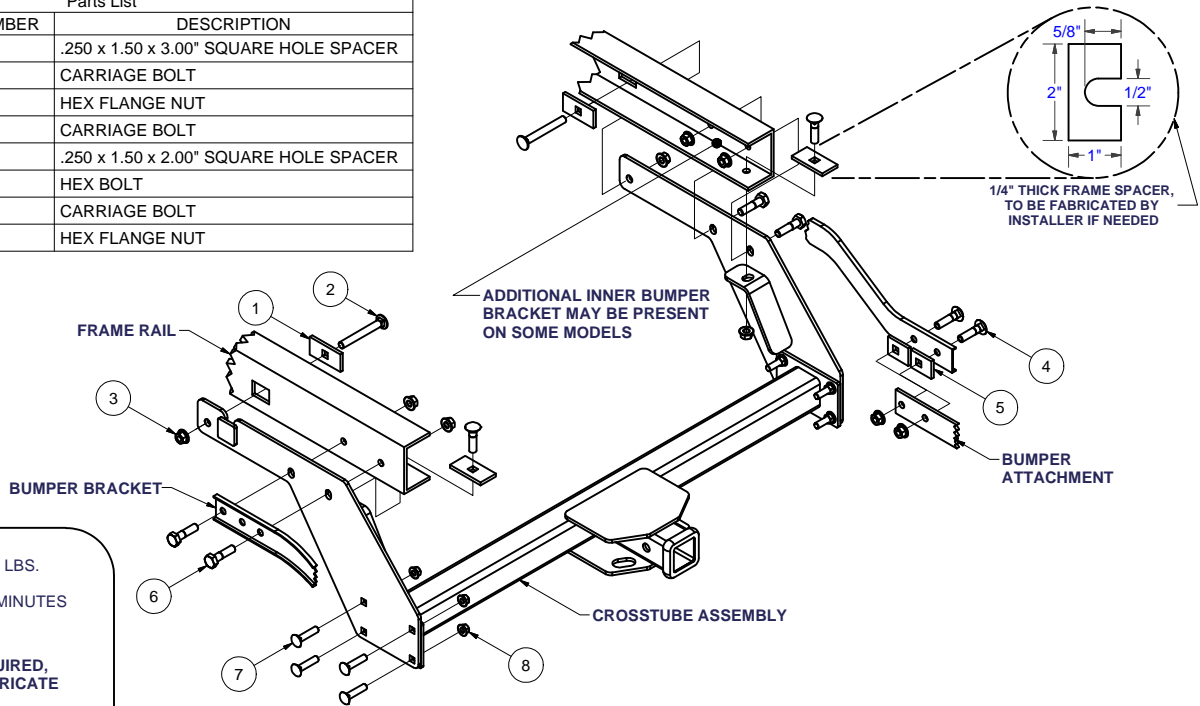

HITCH WEIGHT: 56 LBS.  
 INSTALL TIME: 60 MINUTES  
 INSTALL NOTES:  
 NO DRILLING REQUIRED,  
 MAY NEED TO FABRICATE  
 SPACER

## INSTALLATION STEPS

### VEHICLES WITH BUMPERS

- 1) Remove the bumper from the brackets, remove brackets from frame.
- 2) Remove all but a thin layer of undercoating from the attaching surfaces.
- 3) Position hitch side brackets on the frame, insert 1/2" x 4" carriage bolt, 1/4" x 1 1/2" x 3" spacer, and 1/2" flange nut into forward most holes of the frame, one on each side.
- 4) Loosely install 1/2" x 2" carriage bolt and 1/4" x 3" spacer at the bottom of the frame rail and into side arm support of hitch.
- 5) Position crosstube assembly. Install 7/16" x 2" carriage bolts with 7/16" flange nuts. Torque to 50 lb.-ft.

### 6) VEHICLES WITH BUMPER BRACKETS ON OUTSIDE OF FRAME:

Install bumper brackets so the hitch sides are sandwiched between the frame and the bumper brackets. Install fasteners as shown.

### VEHICLES WITH BUMPER BRACKETS ON INSIDE OF FRAME:

Install bumper brackets in original position with hitch sides positioned on the outside of the frame. Install fasteners as shown.

### VEHICLES WITH BUMPER BRACKETS ON INSIDE AND OUTSIDE OF FRAME.

Reverse inside bumper brackets(left for right/right for left). Install outer bumper brackets so the hitch sides are sandwiched between the frame and the outer bumper brackets. Install fasteners as shown.

**NOTE:** Vehicles with bumper brackets on the inside or inside/outside of the frame may require the fabrication of frame spacers by installer.

- 7) Attach bumper brackets. Install 1/2" x 2" hex bolts and 1/2" flange nuts as shown.

**NOTE:** Vehicles with bumper brackets on the outside of the frame require two 1/4" x 1" x 2" square hole spacers at each attachment. Vehicles with bumper brackets on the inside of frame do not require spacers.

- 8) Torque all 1/2" fasteners to 75 lb.-ft.

### VEHICLES WITHOUT BUMPERS

- 1) Remove all but a thin layer of undercoating from the attaching surfaces, position the hitch side brackets on the frame.
- 2) Position hitch side brackets on the frame.
- 3) Insert 1/2" x 4" carriage bolt, 1/4" x 1 1/2" x 3" spacer, and 1/2" flange nut into forward most holes of the frame, on each side.
- 4) Loosely install 1/2" x 2" carriage bolt, 1/4" x 1 1/2" x 3" spacer at the bottom of the frame rail and into side arm supports of hitch.
- 5) Position crosstube assembly. Install 7/16" x 2" carriage bolts and 7/16" flange nuts. Torque to 50 lb.-ft.
- 6) Install fasteners as shown. Torque 1/2" fasteners to 75 lb.-ft.

PERIODICALLY CHECK THIS RECEIVER HITCH TO ENSURE THAT ALL FASTENERS ARE TIGHT AND THAT ALL STRUCTURAL COMPONENTS ARE SOUND.

Curt Manufacturing Inc., warrants this product to be free of defects in material and/or workmanship at the time of retail purchase by the original purchaser. If the product is found to be defective, Curt Manufacturing Inc., may repair or replace the product, at their option, when the product is returned, prepaid, with proof of purchase. Alteration to, misuse of, or improper installation of this product voids the warranty. Curt Manufacturing Inc.'s liability is limited to repair or replacement of products found to be defective, and specifically excludes liability for incidental or consequential loss or damage.

11/4/2006