



# 13093 INSTALLATION INSTRUCTIONS



Safety glasses should be worn at all times while installing this product.

YEARS: 2011-PRESENT

MAKE: DODGE / CHRYSLER

MODEL: CHARGER / CHALLENGER / 300 / 300S

STYLE: SEDAN / COUPE

**WARNING: NEVER EXCEED YOUR VEHICLE MANUFACTURER'S RECOMMENDED TOWING CAPACITY**







**WEIGHT CARRYING:**  
TRAILER WEIGHT: 3,500 LBS.  
TONGUE WEIGHT: 350 LBS.

**WARNING:**  
WE RECOMMEND THE USE OF 18050 STABILIZING STRAPS FOR ALL NON-TRAILER (WHEEL-LESS) LOADS. PLEASE SEE THE CURT CATALOG OR VISIT US ONLINE AT [WWW.CURTMFG.COM](http://WWW.CURTMFG.COM) FOR FURTHER INFORMATION.

**INSTALLATION TIME: 45 MIN.**

THE INSTALL TIME LISTED IS FOR PROFESSIONAL INSTALLERS. IF YOU ARE HESITANT TO UNDERTAKE THIS TASK ON YOUR OWN, CONTACT AN AUTHORIZED CURT INSTALLER FOR ADDITIONAL ASSISTANCE.





**INSTALLATION REQUIRES:**

 RATCHET	 TORQUE WRENCH	 6" SOCKET EXTENSION
 UNIVERSAL JOINT SOCKET	 13mm 15mm 19mm 3/4" SOCKET	 SAFETY GLASSES

**INSTALLATION TIPS:**

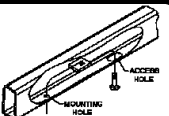
- BEFORE YOU BEGIN INSTALLATION, READ ALL INSTRUCTIONS THOROUGHLY.
- TO EASE INSTALLATION, 2 PEOPLE MAY BE REQUIRED.
- USING PROPER TOOLS WILL GREATLY IMPROVE THE QUALITY OF THE INSTALL AND REDUCE THE TIME REQUIRED.
- NEED HELP OR HAVE SOME QUESTIONS? CALL TECHNICAL SUPPORT AT 800.798.0813

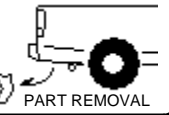
**LEVEL OF DIFFICULTY: MODERATE**

EASY	MODERATE	CHALLENGING
	FISHWIRE HARDWARE	
	REMOVE EXHAUST ISOLATORS	
	REMOVE DRIVER SIDE MUFFLER	
	NO DRILLING REQUIRED	

**VEHICLE PHOTO:**



REPRESENTATIVE PHOTO

**HITCH ILLUSTRATION:**

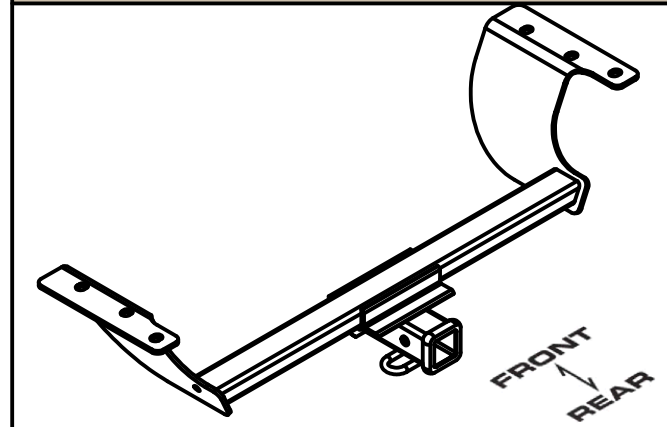

MAKE SURE YOUR HITCH MATCHES

**PERIODICALLY CHECK THIS RECEIVER HITCH TO ENSURE ALL FASTENERS ARE TIGHT AND ALL STRUCTURAL COMPONENTS ARE SOUND**

CURT Manufacturing LLC. warrants this product to be free of defects in material and/or workmanship at the time of retail purchase by the original purchaser. If the product is found to be defective, Curt Manufacturing LLC. may repair or replace the product at their option, when the product is returned, prepaid, with proof of purchase. Alteration to, misuse of, or improper installation of this product voids the warranty. Curt Manufacturing LLC.'s liability is limited to repair or replacement of products found to be defective, and specifically excludes liability for incidental or consequential loss or damage.

For more information log onto [www.curtmfg.com](http://www.curtmfg.com), & for helpful towing tips log onto [www.hitchinfo.com](http://www.hitchinfo.com)

## INSTALLATION WALKTHROUGH:

Parts List			
ITEM	QTY	PART NUMBER	DESCRIPTION
1	3	1_2 FISHWIRE	1/2" FISHWIRE
2	3	M12-1.75 x 40mm	HEX BOLT
3	3	1/2"	CONICAL TOOTHED WASHER
4	3	HFN 1213	HEX FLANGE NUT
5	3	CM-SP40	.188 x 1.00 x 3.00" SQUARE HOLE SPACER
6	3	1/2-13 x 1 3/4	CARRIAGE BOLT

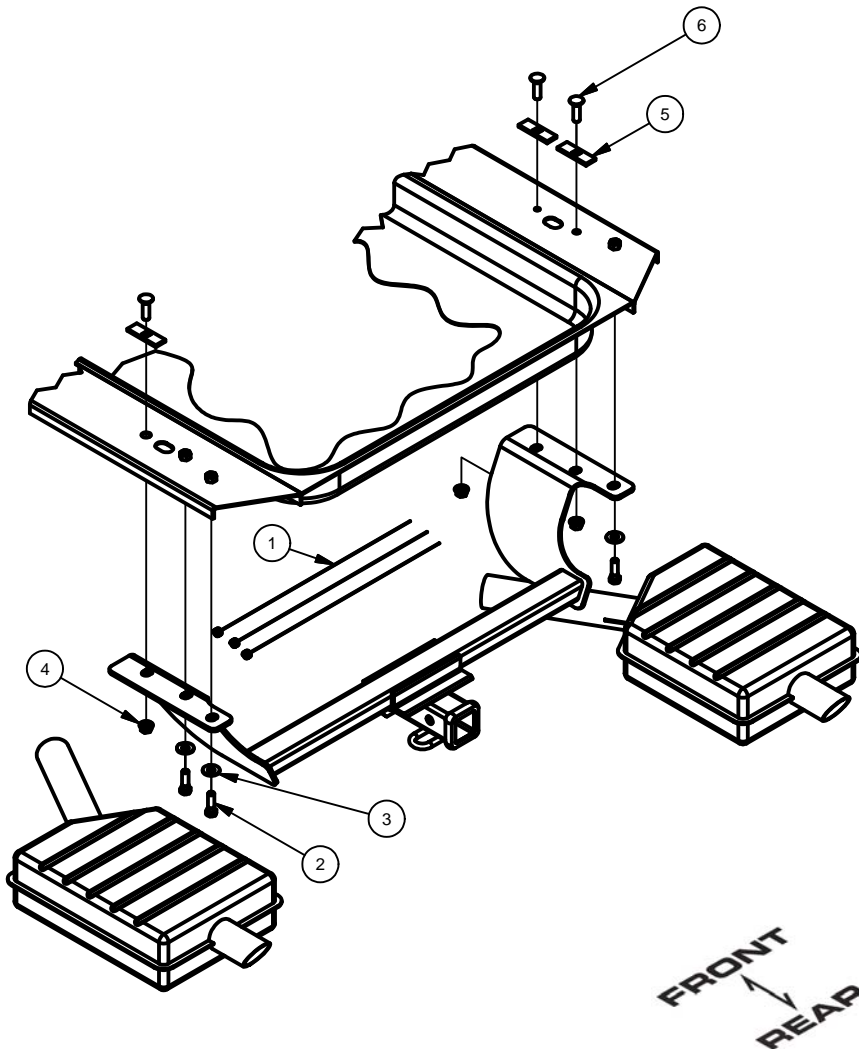

1. Locate and remove (2) exhaust isolators near muffler on driver and passenger side of vehicle. Save bolts for reinstallation.



2. Locate and remove (2) rubber isolators from exhaust pipe.



## INSTALLATION WALKTHROUGH:

3. On V6 models: Locate and remove nut from exhaust clamp that holds the driver side muffler. Save nut for reinstallation.

On V8 models: Locate and remove (2) nuts with springs attaching driver side muffler. Save nuts and springs for reinstallation.

Slide and remove driver side muffler/tube off of remaining exhaust system.



4. Fishwire 1/2" carriage bolts and CM-SP40 spacers through access hole on driver and passenger side frame rail. Pull hardware through existing holes (2 on passenger side and 1 on driver side).



5. Raise hitch into position by placing passenger side of hitch over the passenger side muffler first and then raise the driver side of hitch. Secure hitch to existing weldnuts with supplied M12 hardware and conical toothed washers. Attach 1/2" hex flange nuts onto carriage bolts.



6. Torque 1/2" hardware to 75 lb-ft and M12 hardware to 65 lb-ft.



## INSTALLATION WALKTHROUGH:

7. On V6 Models: Slide driver side muffler/tube back into position against stud on exhaust system. Secure clamp with nut from Step 3.
- On V8 Models: Reattach driver side muffler onto studs with nuts and springs from Step 3.

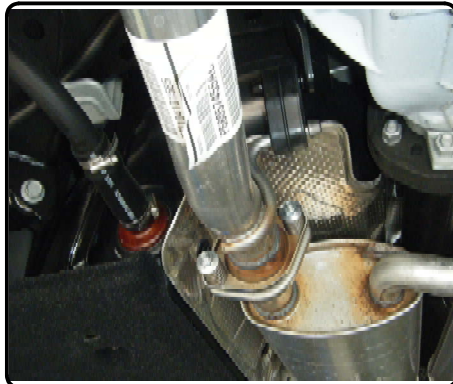

8. Raise exhaust back into position and reattach (2) exhaust isolators. Reinstall (4) exhaust hangers removed in Step 1.



GROSS LOAD CAPACITY WHEN USED AS A WEIGHT CARRYING HITCH: 3,500 LBS. TRAILER WEIGHT & 350 LBS. TONGUE WEIGHT.

\*\*\*DO NOT EXCEED VEHICLE MANUFACTURER'S RECOMMENDED TOWING CAPACITY.\*\*\*

WARNING: ALL NON-TRAILER LOADS APPLIED TO THIS PRODUCT MUST BE SUPPORTED BY 18050 STABILIZING STRAPS.

\*\* FAILURE TO PROPERLY SUPPORT NON-TRAILER LOADS WILL VOID PRODUCT WARRANTY\*\*

HAVING INSTALLATION QUESTIONS? CALL TECHNICAL SUPPORT AT 1-800-798-0813

Parts List			
ITEM	QTY	PART NUMBER	DESCRIPTION
1	3	1_2 FISHWIRE	1/2" FISHWIRE
2	3	M12-1.75 x 40mm	HEX BOLT
3	3	1/2"	CONICAL TOOTHED WASHER
4	3	HFN 1213	HEX FLANGE NUT
5	3	CM-SP40	.188 x 1.00 x 3.00" SQUARE HOLE SPACER
6	3	1/2-13 x 1 3/4	CARRIAGE BOLT

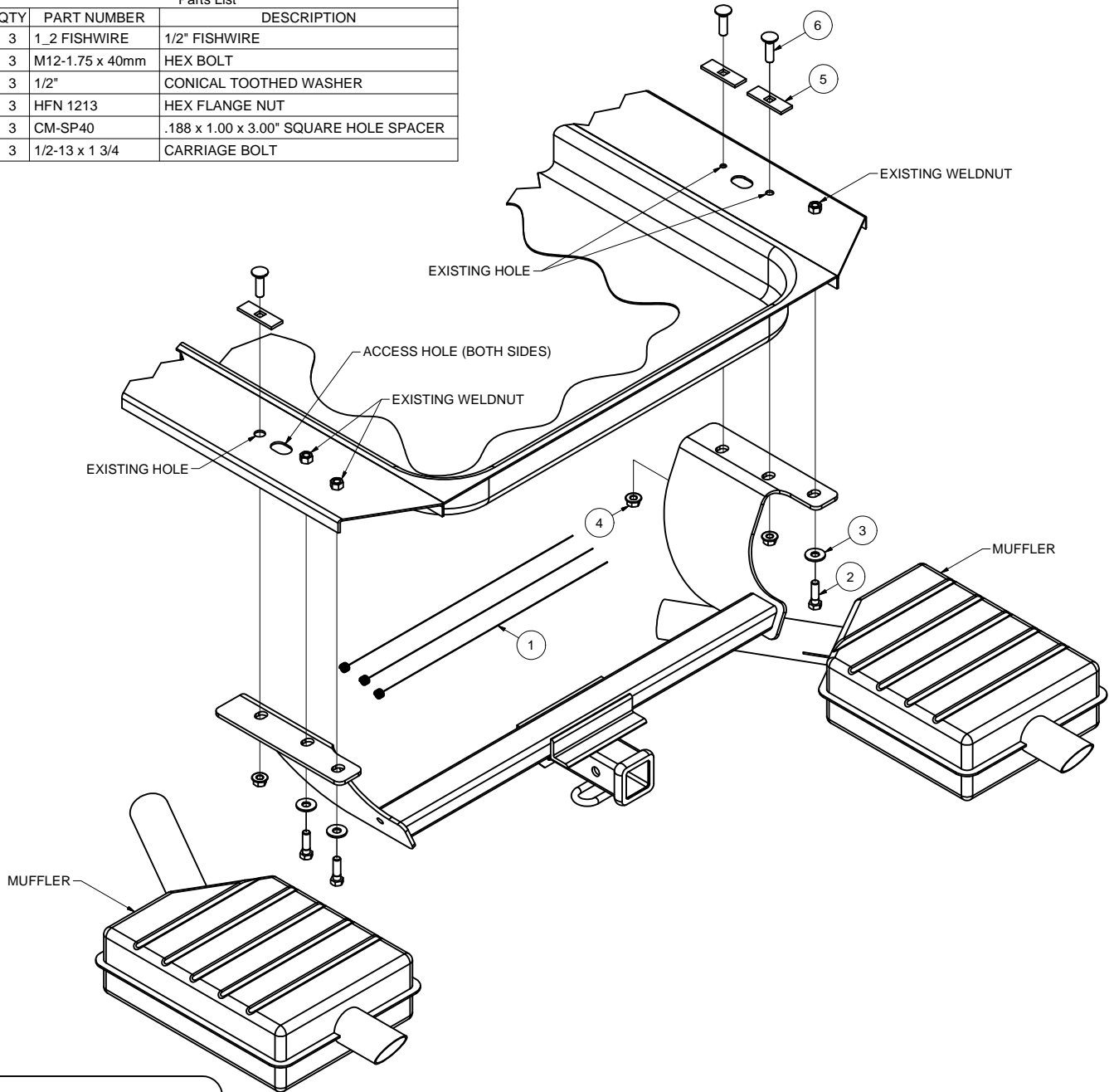

HITCH WEIGHT: 34 LBS.

INSTALL TIME

PROFESSIONAL: 45 MINUTES

NOVICE (DIY): 90 MINUTES

INSTALL NOTES:

- LOWER EXHAUST
- FISHWIRE HARDWARE
- REMOVE DRIVER SIDE MUFFLER
- NO DRILLING REQUIRED



PERIODICALLY CHECK THIS RECEIVER HITCH TO ENSURE THAT ALL FASTENERS ARE TIGHT AND THAT ALL STRUCTURAL COMPONENTS ARE SOUND.

Curt Manufacturing LLC., warrants this product to be free of defects in material and/or workmanship at the time of retail purchase by the original purchaser. If the product is found to be defective, Curt Manufacturing LLC., may repair or replace the product, at their option, when the product is returned, prepaid, with proof of purchase. Alteration to, misuse of, or improper installation of this product voids the warranty. Curt Manufacturing LLC.'s liability is limited to repair or replacement of products found to be defective, and specifically excludes liability for incidental or consequential loss or damage.

HAVING INSTALLATION QUESTIONS? CALL TECHNICAL SUPPORT AT 1-800-798-0813

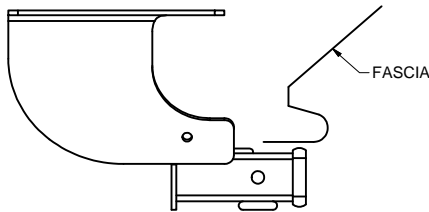
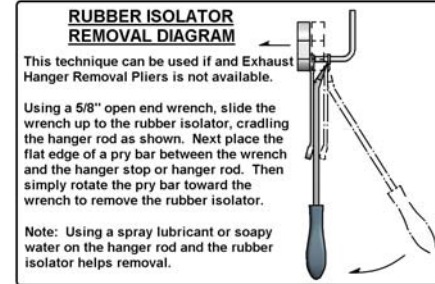
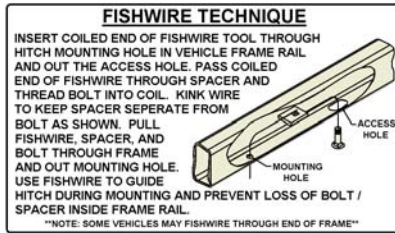

INSTALLED HITCH POSITION

TOOLS REQUIRED
RATCHET
TORQUE WRENCH
6" SOCKET EXTENSION
SOCKET UNIVERSAL JOINT
13mm SOCKET
15mm SOCKET
19mm SOCKET
3/4" SOCKET

## INSTALLATION STEPS

1. Locate and remove (2) exhaust isolators near muffler on driver and passenger side of vehicle. Save bolts for reinstallation.
2. Locate and remove (2) rubber isolators from exhaust pipe. (See RUBBER ISOLATOR REMOVAL DIAGRAM)
3. On V6 models: Locate and remove nut from exhaust clamp that holds the driver side muffler. Save nut for reinstallation.  
On V8 models: Locate and remove (2) nuts with springs attaching driver side muffler. Save nuts and springs for reinstallation.
4. Slide and remove driver side muffler/tube off of remaining exhaust system.
5. Fishwire 1/2" carriage bolts and CM-SP40 spacers through access hole on driver and passenger side frame rail. Pull hardware through existing holes (2 on passenger side and 1 on driver side). (See FISHWIRE TECHNIQUE diagram.)
6. Raise hitch into position by placing passenger side of hitch over the passenger side muffler first and then raise the driver side of hitch.
7. Secure hitch with supplied M12 hardware and conical toothed washers. Attach 1/2" hex flange nuts onto carriage bolts.
8. Torque 1/2" hardware to 110 lb-ft and M12 hardware to 79 lb-ft.
9. On V6 Models: Slide driver side muffler/tube back into position against stud on exhaust system. Secure clamp with nut from Step 3.  
On V8 Models: Reattach driver side muffler onto studs with nuts and springs from Step 3.
10. Raise exhaust back into position and reattach (2) exhaust isolators.
11. Reinstall (4) exhaust hangers from Step 1.

**PERIODICALLY CHECK THIS RECEIVER HITCH TO ENSURE THAT ALL FASTENERS ARE TIGHT AND THAT ALL STRUCTURAL COMPONENTS ARE SOUND.**