

13098 / 757200

96-99 ACURA SLX SUV
92-02 ISUZU TROOPER & TROOPER II SUV

10/6/2011

GROSS LOAD CAPACITY WHEN USED AS A WEIGHT CARRYING HITCH: 5,000 LBS. TRAILER WEIGHT & 500 LBS. TONGUE WEIGHT.
GROSS LOAD CAPACITY WHEN USED AS A WEIGHT DISTRIBUTION HITCH: 6,000 LBS. TRAILER WEIGHT & 600 LBS. TONGUE WEIGHT

DO NOT EXCEED VEHICLE MANUFACTURER'S RECOMMENDED TOWING CAPACITY.

Parts List			
ITEM	QTY	PART NUMBER	DESCRIPTION
1	6	FW12	FW, 12, ZP
2	6	M12-1.25 x 30mm	HEX BOLT
3	6	1/2"	LOCK WASHER

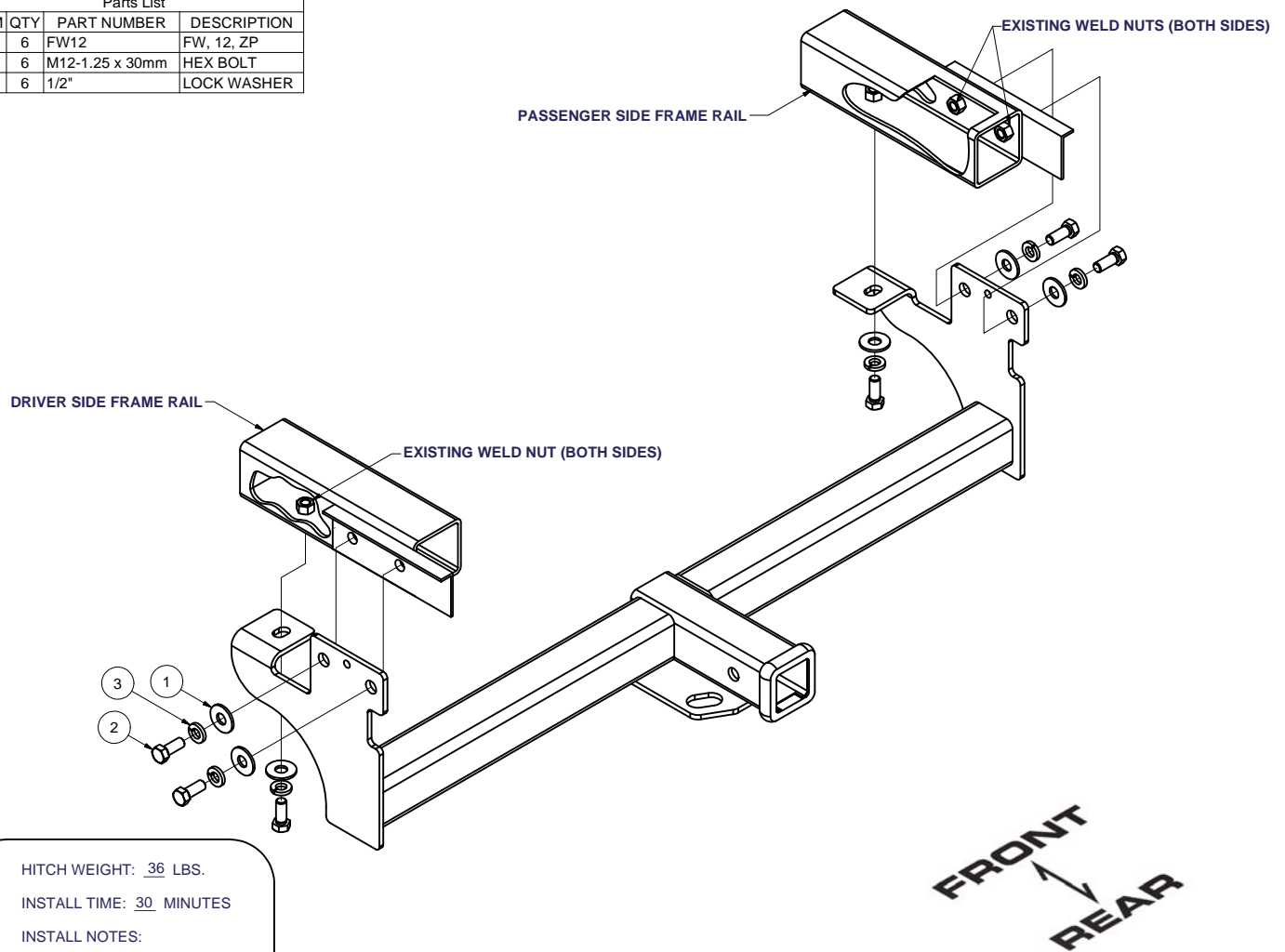

HITCH WEIGHT: 36 LBS.

INSTALL TIME: 30 MINUTES

INSTALL NOTES:

NO DRILL
REMOVE TOW HOOK

INSTALLATION STEPS

1) Remove tow hook from the metal bracket welded to the bottom surface of the frame on passenger side. Return bolts and tow hook to vehicle owner for reinstallation.

Note: do not remove the metal bracket

2) Position hitch on vehicle, and mount to frame rails using fasteners provided.

3) Remove 12 mm bolts from frame and return to owner, Mount hitch to existing 12 mm holes in frame sides where bumper brackets attach to the frame and to existing 12 mm holes in bottom of frame rail. Hitch side plates mount to the outside of bumper brackets; bumper brackets are not disturbed.

4) Torque all 12 mm fasteners to 68 lb.-ft.

PERIODICALLY CHECK THIS RECEIVER HITCH TO ENSURE THAT ALL FASTENERS ARE TIGHT AND THAT ALL STRUCTURAL COMPONENTS ARE SOUND.

Curt Manufacturing Inc., warrants this product to be free of defects in material and/or workmanship at the time of retail purchase by the original purchaser. If the product is found to be defective, Curt Manufacturing Inc., may repair or replace the product, at their option, when the product is returned, prepaid, with proof of purchase. Alteration to, misuse of, or improper installation of this product voids the warranty. Curt Manufacturing Inc.'s liability is limited to repair or replacement of products found to be defective, and specifically excludes liability for incidental or consequential loss or damage.

10/25/2006