



Safety glasses should be worn at all times while installing this product.

YEARS: 09-PRESENT

MAKE: AUDI

MODEL: Q5

STYLE: SUV

WARNING: NEVER EXCEED YOUR VEHICLE MANUFACTURER'S RECOMMENDED TOWING CAPACITY

WEIGHT CARRYING:
 TRAILER WEIGHT: 5000 LBS.
 TONGUE WEIGHT: 750 LBS.

WARNING:
 WE RECOMMEND THE USE OF 18050 STABILIZING STRAPS FOR ALL NON-TRAILER (WHEEL-LESS) LOADS. PLEASE SEE THE CURT CATALOG OR VISIT US ONLINE AT WWW.CURTMFG.COM FOR FURTHER INFORMATION.

INSTALLATION TIME: 30-60 MIN.
 THE INSTALL TIME LISTED IS FOR PROFESSIONAL /NOVICE INSTALLERS. IF YOU ARE HESITANT TO UNDERTAKE THIS TASK ON YOUR OWN, CONTACT AN AUTHORIZED CURT INSTALLER FOR ADDITIONAL ASSISTANCE.

INSTALLATION TIPS:

- BEFORE YOU BEGIN INSTALLATION, READ ALL INSTRUCTIONS THOROUGHLY.
- TO EASE INSTALLATION, 2 PEOPLE MAY BE REQUIRED.
- USING PROPER TOOLS WILL GREATLY IMPROVE THE QUALITY OF THE INSTALL AND REDUCE THE TIME REQUIRED.
- NEED HELP OR HAVE SOME QUESTIONS? CALL TECHNICAL SUPPORT AT 800.798.0813



INSTALLATION REQUIRES:

SAFETY GLASSES	T-20 TORXBIT SOCKET	SOCKET 3/4" 9/16" 13mm
RATCHET	TORQUE WRENCH	

LEVEL OF DIFFICULTY: MODERATE

EASY	MODERATE	CHALLENGING
	BUMPER REMOVAL REQUIRED	
	LOWER EXHAUST HANGER	
	NO DRILLING REQUIRED	
	SILICONE / SEALANT ADVISED	

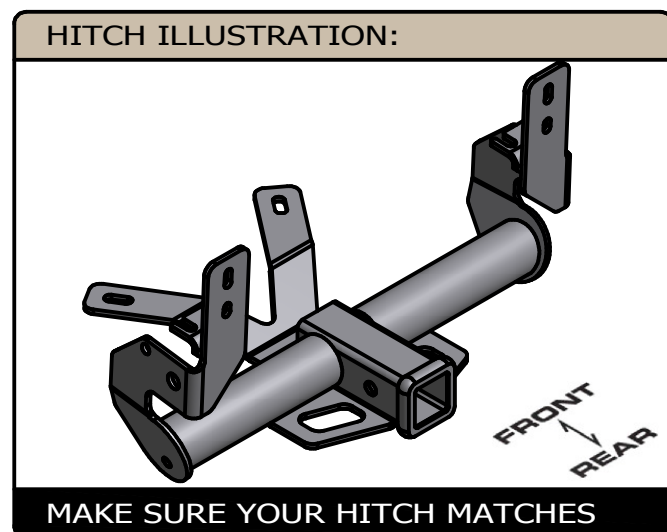

PERIODICALLY CHECK THIS RECEIVER HITCH TO ENSURE ALL FASTENERS ARE TIGHT AND ALL STRUCTURAL COMPONENTS ARE SOUND

CURT Manufacturing LLC. warrants this product to be free of defects in material and/or workmanship at the time of retail purchase by the original purchaser. If the product is found to be defective, Curt Manufacturing LLC. may repair or replace the product at their option, when the product is returned, prepaid, with proof of purchase. Alteration to, misuse of, or improper installation of this product voids the warranty. Curt Manufacturing LLC.'s liability is limited to repair or replacement of products found to be defective, and specifically excludes liability for incidental or consequential loss or damage.

For more information log onto www.curtmfg.com, & for helpful towing tips log onto www.hitchinfo.com

INSTALLATION WALKTHROUGH:

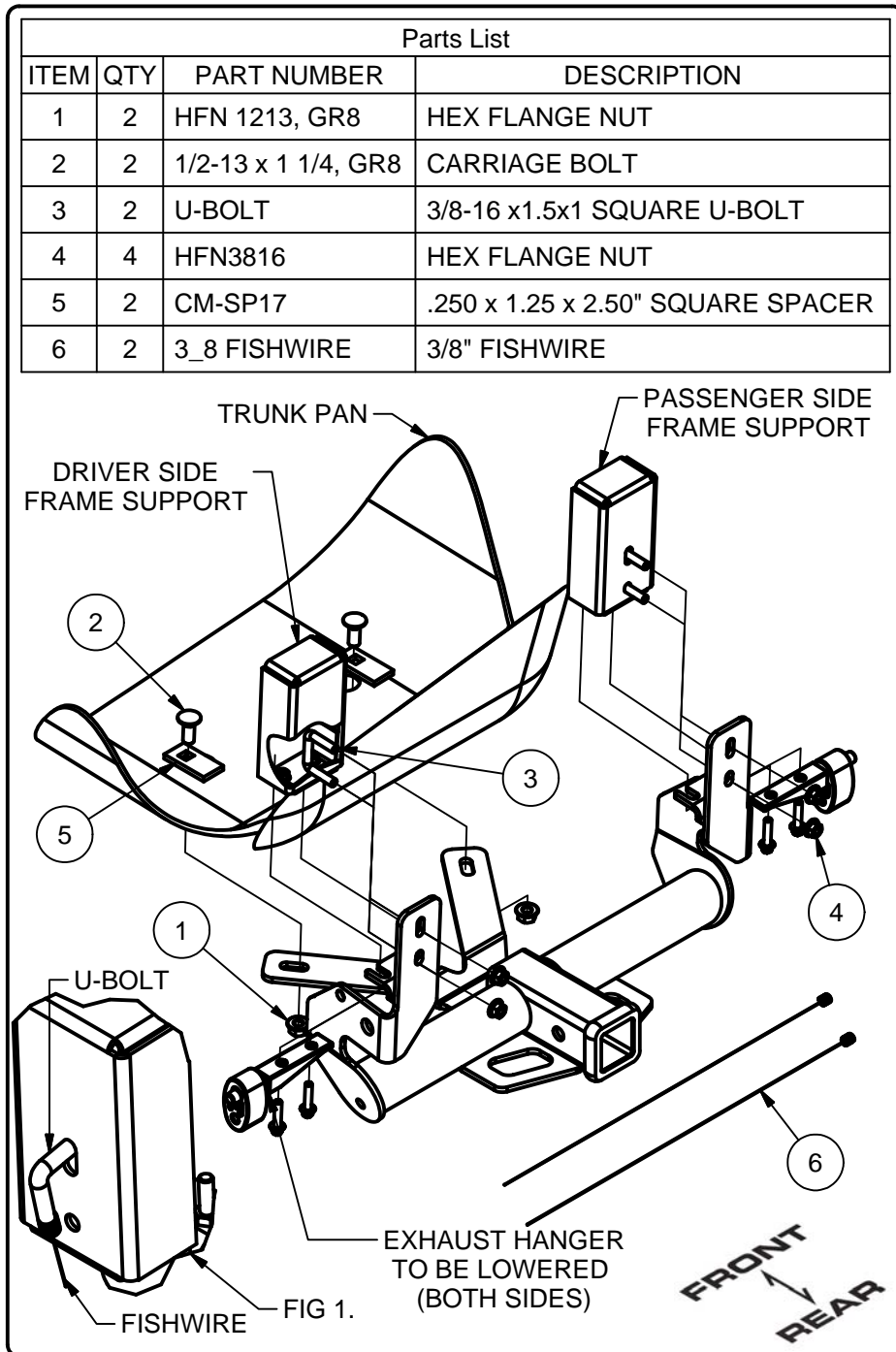

1. Remove the bumper fascia by removing (4) T-20 Torx bit screws (2) from the trunk (1) from each wheel well, and disconnect 1 snap tab on each side from the bumper to the support strap.



2. Remove lower bumper fascia by lightly pulling along the snap groove, which spans the length of the bumper and disconnect (4) sensor plugs.

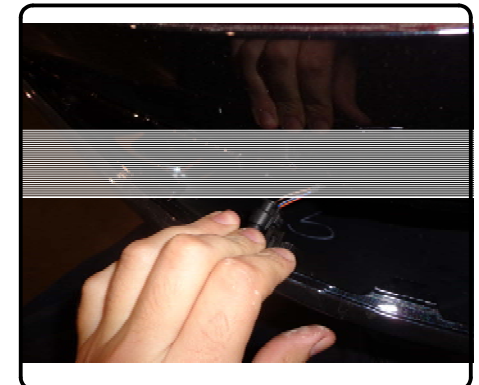

INSTALLATION WALKTHROUGH:

3. Lower the exhaust hanger from each side of the vehicle frame support by removing (2) 8mm bolts from each exhaust hanger bracket. Cut around the (2) trunk pan plugs and return to customer.



4. Insert the 1/2" carriage bolt and spacer into the trunk pan holes. Apply caulk/sealant to the area between the trunk pan hole and hitch. Raise hitch into position and lightly secure with 1/2" hardware.

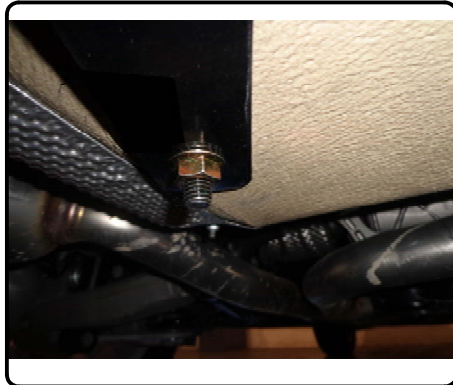
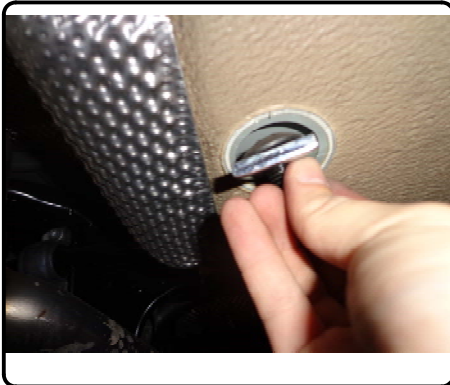

5. Install the u-bolts in the frame rail support as shown in Fig 1. Resecure the exhaust bracket each side, clamping the hitch mounting strap between the frame support and the hanger bracket by replacing 8mm bolts removed in step 3.

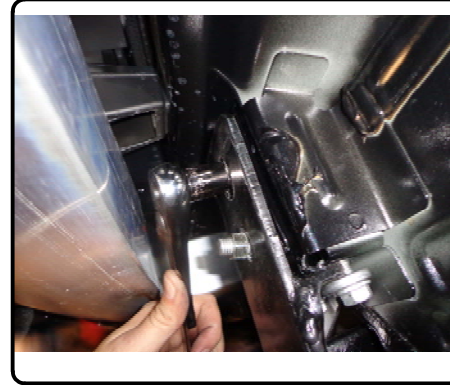

6. In sequence, torque 1/2" hardware to 110 lb-ft, 8mm bolts to 17 lb-ft, and 3/8 u-bolt to 16 lb-ft. Reinstall lower bumper fascia by following steps 1-2 in reverse. Installation complete.

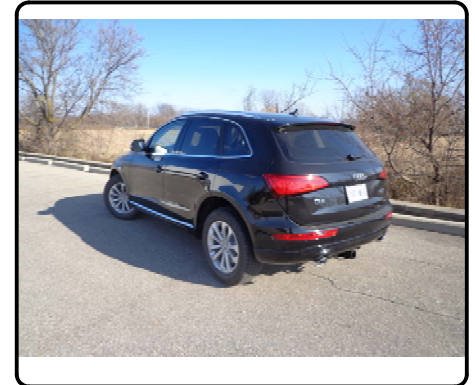

GROSS LOAD CAPACITY WHEN USED AS A WEIGHT CARRYING HITCH: 5000 LBS. TRAILER WEIGHT & 750 LBS. TONGUE WEIGHT.

DO NOT EXCEED VEHICLE MANUFACTURER'S RECOMMENDED TOWING CAPACITY.

WARNING: ALL NON-TRAILER LOADS APPLIED TO THIS PRODUCT MUST BE SUPPORTED BY 18050 STABILIZING STRAPS.

** FAILURE TO PROPERLY SUPPORT NON-TRAILER LOADS WILL VOID PRODUCT WARRANTY**

HAVING INSTALLATION QUESTIONS? CALL TECHNICAL SUPPORT AT 1-800-798-0813

Parts List			
ITE	QT	PART NUMBER	DESCRIPTION
1	2	HFN 1213, GR8	HEX FLANGE NUT
2	2	1/2-13 x 1 1/4, GR8	CARRIAGE BOLT
3	2	U-BOLT	3/8-16 x1.5x1 SQUARE U-BOLT
4	4	HFN3816	HEX FLANGE NUT
5	2	CM-SP17	.250 x 1.25 x 2.50" SQUARE HOLE SPACER
6	2	3_8 FISHWIRE	3/8" FISHWIRE

TOOLS REQUIRED
T-20 TORX BIT
3/4" SOCKET
9/16" SOCKET
13mm SOCKET
RATCHET
TORQUE WRENCH

RUBBER ISOLATOR REMOVAL DIAGRAM

This technique can be used if an Exhaust Hanger Removal Pliers is not available.

Using a 5/8" open end wrench, slide the wrench up to the rubber isolator, cradling the hanger rod as shown. Next place the flat edge of a pry bar between the wrench and the hanger stop or hanger rod. Then simply rotate the pry bar toward the wrench to remove the rubber isolator.

Note: Using a spray lubricant or soapy water on the hanger rod and the rubber isolator helps removal.

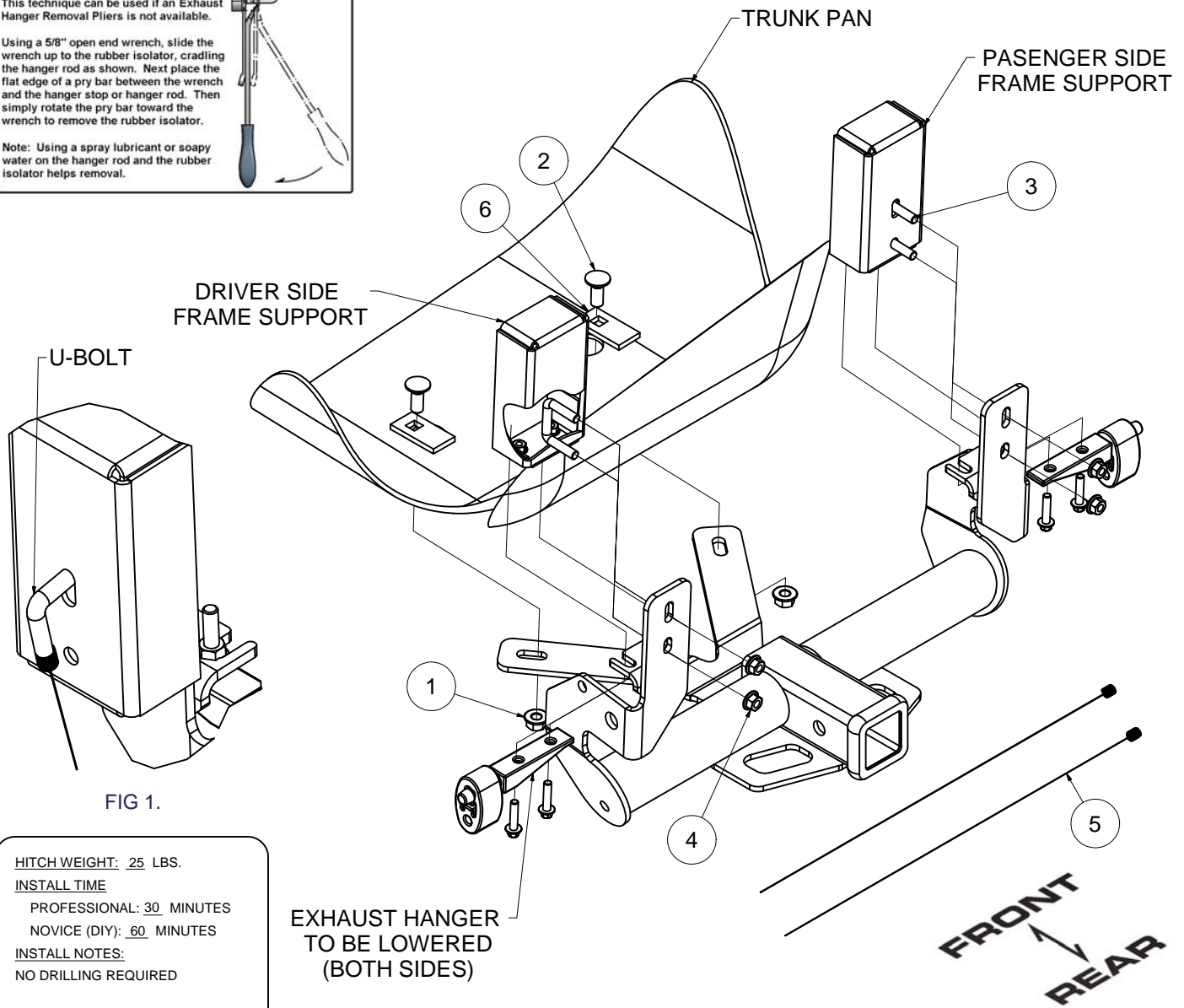

FIG 1.

HITCH WEIGHT: 25 LBS.
INSTALL TIME
 PROFESSIONAL: 30 MINUTES
 NOVICE (DIY): 60 MINUTES
INSTALL NOTES:
 NO DRILLING REQUIRED

EXHAUST HANGER TO BE LOWERED (BOTH SIDES)

PERIODICALLY CHECK THIS RECEIVER HITCH TO ENSURE THAT ALL FASTENERS ARE TIGHT AND THAT ALL STRUCTURAL COMPONENTS ARE SOUND.

Curt Manufacturing LLC., warrants this product to be free of defects in material and/or workmanship at the time of retail purchase by the original purchaser. If the product is found to be defective, Curt Manufacturing LLC., may repair or replace the product, at their option, when the product is returned, prepaid, with proof of purchase. Alteration to, misuse of, or improper installation of this product voids the warranty. Curt Manufacturing LLC.'s liability is limited to repair or replacement of products found to be defective, and specifically excludes liability for incidental or consequential loss or damage.

INSTALLATION STEPS

1. Remove the bumper fascia by removing (4) T-20 Torx bit screws (2) from the trunk (1) from each wheel well, and disconnect 1 snap tab on each side from the bumper to the support strap.
2. Remove lower bumper fascia by lightly pulling along the snap groove, which spans the length of the bumper and disconnect (4) sensor plugs.
3. Lower the exhaust hanger from each side of the vehicle frame support by removing (2) 8mm bolts from each exhaust hanger bracket. Cut around the (2) trunk pan plugs and return to customer.
4. Insert the 1/2" carriage bolt and spacer into the trunk pan holes. Apply caulk/sealant to the area between the trunk pan hole and hitch. Raise hitch into position and lightly secure with 1/2" hardware.
5. Install the u-bolts in the frame rail support as shown in Fig 1. Resecure the exhaust bracket each side, clamping the hitch mounting strap between the frame support and the hanger bracket by replacing 8mm bolts removed in step 3.
6. In sequence, torque 1/2" hardware to 110 lb-ft, 8mm bolts to 17 lb-ft, and 3/8 u-bolt to 16 lb-ft.
7. Reinstall lower bumper fascia by following steps 1-2 in reverse.
8. Installation complete.

PERIODICALLY CHECK THIS RECEIVER HITCH TO ENSURE THAT ALL FASTENERS ARE TIGHT AND THAT ALL STRUCTURAL COMPONENTS ARE SOUND.