

13145 87-04 DODGE DAKOTA PICKUP (2 & 4 WD)(2 & 4 DR)

10/10/2011

GROSS LOAD CAPACITY WHEN USED AS A WEIGHT CARRYING HITCH: 5,000 LBS. TRAILER WEIGHT & 500 LBS. TONGUE WEIGHT.
GROSS LOAD CAPACITY WHEN USED AS A WEIGHT DISTRIBUTION HITCH: 6,000 LBS. TRAILER WEIGHT & 600 LBS. TONGUE WEIGHT

DO NOT EXCEED VEHICLE MANUFACTURER'S RECOMMENDED TOWING CAPACITY.

Parts List			
ITEM	QTY	PART NUMBER	DESCRIPTION
1	4	HFN 1213	HEX FLANGE NUT
2	2	7/16-14	HEX FLANGE NUT
3	4	1/2-13 x 1 3/4	CARRIAGE BOLT
4	4	CM-SP1	.250 x 1.50 x 2.00" SQUARE HOLE SPACER
5	2	7/16-14 x 1 1/2	HEX BOLT

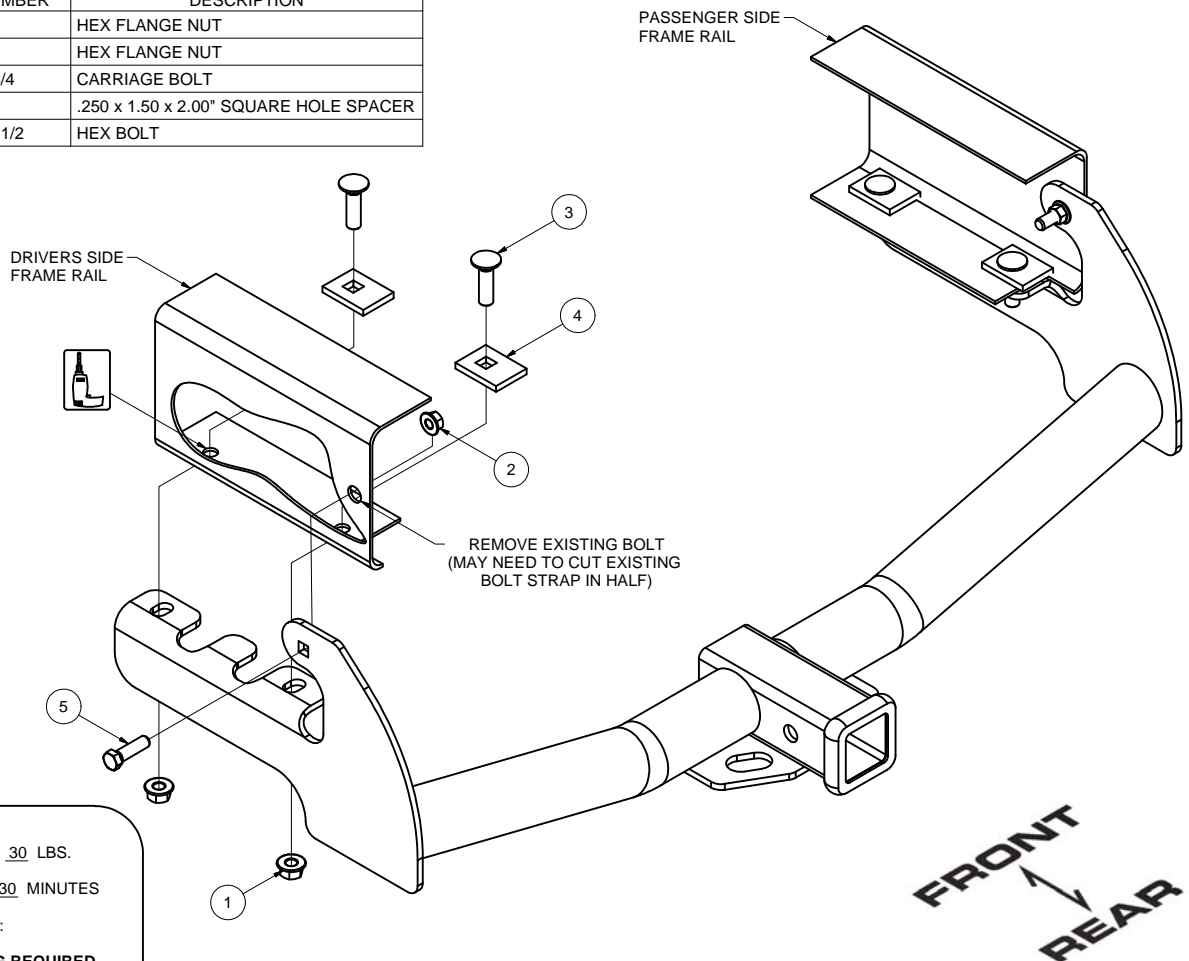

HITCH WEIGHT: 30 LBS.

INSTALL TIME: 30 MINUTES

INSTALL NOTES:

DRILLING REQUIRED

INSTALLATION STEPS

- 1) **Remove rearmost bolt** at the end of the frame on both sides.
NOTE: The rearmost bolts on some models are connected with a plate. Remove and cut the plate midway between the bolts. Discard the rearmost and reinstall the other.
- 2) **Position the hitch** on vehicle and install 7/16" fasteners.
- 3) **95 and earlier:** using the side bracket of the receiver as a template, drill two holes into bottom of frame rail with a 1/2 " bit. Repeat of other side.
87-96 models: Using the side bracket of the receiver as a template, drill forward attachment hole into bottom of frame rail with a 1/2 " bit. Repeat of other side.
97-Current models: align hitch with existing holes.
- 4) **Install remaining 1/2" fasteners** as shown.
- 5) Torque all 7/16" hardware to 50 ft-lbs and all 1/2" hardware to 75 ft-lbs.
- 6) **Note:** Exhaust hanger may need to be repositioned.

PERIODICALLY CHECK THIS RECEIVER HITCH TO ENSURE THAT ALL FASTENERS ARE TIGHT AND THAT ALL STRUCTURAL COMPONENTS ARE SOUND.

Curt Manufacturing Inc., warrants this product to be free of defects in material and/or workmanship at the time of retail purchase by the original purchaser. If the product is found to be defective, Curt Manufacturing Inc., may repair or replace the product, at their option, when the product is returned, prepaid, with proof of purchase. Alteration to, misuse of, or improper installation of this product voids the warranty. Curt Manufacturing Inc.'s liability is limited to repair or replacement of products found to be defective, and specifically excludes liability for incidental or consequential loss or damage.