

13154**ACURA RDX****10/11/2011****GROSS LOAD CAPACITY WHEN USED AS A WEIGHT CARRYING HITCH: 4,000 LBS. TRAILER WEIGHT & 400 LBS. TONGUE WEIGHT.**

DO NOT EXCEED VEHICLE MANUFACTURER'S RECOMMENDED TOWING CAPACITY.

WARNING: ALL NON-TRAILER LOADS APPLIED TO THIS PRODUCT MUST BE SUPPORTED BY 18050 STABILIZING STRAPS.

** FAILURE TO PROPERLY SUPPORT NON-TRAILER LOADS WILL VOID PRODUCT WARRANTY**

HAVING INSTALLATION QUESTIONS? CALL TECHNICAL SUPPORT AT 1-800-798-0813

Parts List			
ITEM	QTY	PART NUMBER	DESCRIPTION
1	2	M12 - 1.25 x 40 HEX	HEX BOLT
2	2	1/2 - 13 x 1 1/2	HEX BOLT
3	4	1/2"	CONICAL TOOTHED WASHER
4	2	1/2-13	HANDLE NUT

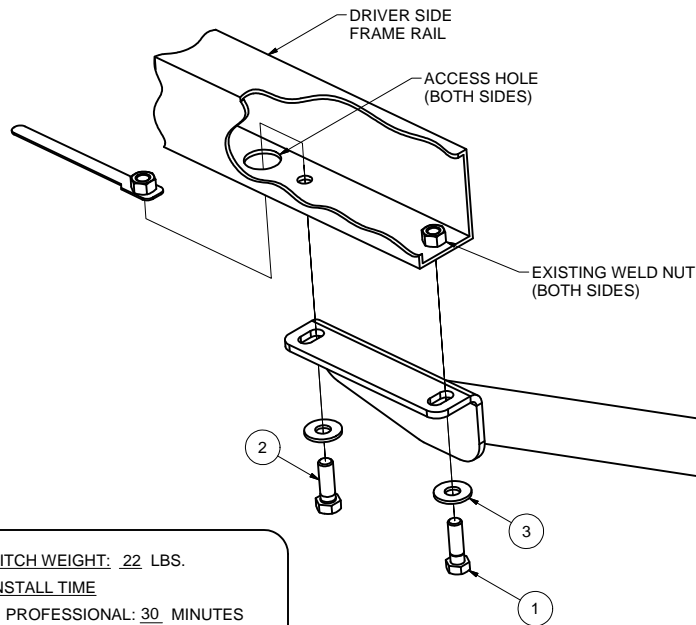
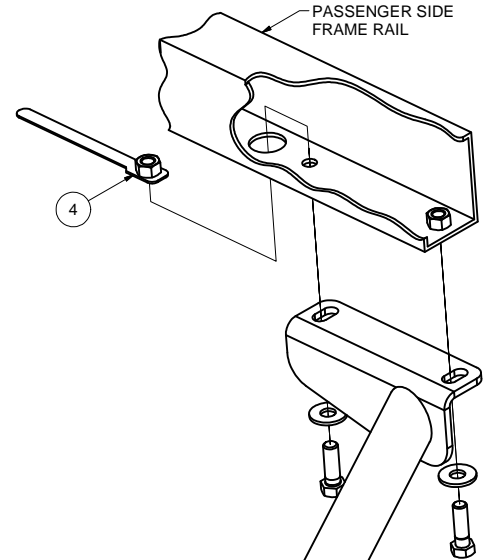
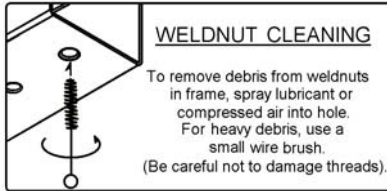
**HITCH WEIGHT: 22 LBS.****INSTALL TIME**

PROFESSIONAL: 30 MINUTES

NOVICE (DIY): 60 MINUTES

INSTALL NOTES:

-NO DRILLING REQUIRED

FRONT
↑
REAR**INSTALLATION STEPS:**

1. Raise hitch into position so the slots in the hitch are aligned with the two existing weldnuts in the vehicle frame. Loosely secure with M12 bolts and 1/2" conical toothed washers.
2. Bend the 1/2-13 handle nut tab and insert it into the access hole in the vehicle frame. Center the handle nut over the open bolt hole in frame. Use 1/2-13 hex bolts and 1/2" conical toothed washers and insert hardware through hitch plate and vehicle frame into the handle nut and tighten.
3. Torque all 1/2" hardware to 75 ft-lbs and all M12 hardware to 72 ft-lbs.

PERIODICALLY CHECK THIS RECEIVER HITCH TO ENSURE THAT ALL FASTENERS ARE TIGHT AND THAT ALL STRUCTURAL COMPONENTS ARE SOUND.

Curt Manufacturing Inc., warrants this product to be free of defects in material and/or workmanship at the time of retail purchase by the original purchaser. If the product is found to be defective, Curt Manufacturing Inc., may repair or replace the product, at their option, when the product is returned, prepaid, with proof of purchase. Alteration to, misuse of, or improper installation of this product voids the warranty. Curt Manufacturing Inc.'s liability is limited to repair or replacement of products found to be defective, and specifically excludes liability for incidental or consequential loss or damage.