



Safety glasses should be worn at all times while installing this product.

YEARS: 2015

MAKE: CHEVROLET/GMC

MODEL: COLORADO/CANYON

STYLE: PICK-UP

WARNING: NEVER EXCEED YOUR VEHICLE MANUFACTURER'S RECOMMENDED TOWING CAPACITY

WEIGHT CARRYING:
 TRAILER WEIGHT: 8,000 LBS.
 TONGUE WEIGHT: 800 LBS.

WEIGHT DISTRIBUTION:
 TRAILER WEIGHT: 10,000 LBS.
 TONGUE WEIGHT: 1,000 LBS.

PRO INSTALL TIME: 30 MIN.
NOVICE INSTALL TIME: 60 MIN.

IF YOU ARE HESITANT TO UNDERTAKE THIS TASK ON YOUR OWN, CONTACT AN AUTHORIZED CURT INSTALLER FOR ADDITIONAL ASSISTANCE.

INSTALLATION TIPS:

- BEFORE YOU BEGIN INSTALLATION, READ ALL INSTRUCTIONS THOROUGHLY.
- TO EASE INSTALLATION, 2 PEOPLE MAY BE REQUIRED.
- USING PROPER TOOLS WILL GREATLY IMPROVE THE QUALITY OF THE INSTALL AND REDUCE THE TIME REQUIRED.
- NEED HELP OR HAVE SOME QUESTIONS? CALL TECHNICAL SUPPORT AT 800.798.0813



INSTALLATION REQUIRES:

SAFETY GLASSES	RATCHET	13mm 21mm SOCKET
9" SOCKET EXTENSION	JACK STANDS	SPRAY LUBRICANT
WIRE PIPE BRUSH	TORQUE WRENCH	

LEVEL OF DIFFICULTY: MODERATE

EASY	MODERATE	CHALLENGING
	TEMPORARILY LOWER SPARE TIRE	
	REMOVE FACTORY CROSSMEMBER/HITCH	
	CLEAN WELDNUTS AS NEEDED	
	NO DRILLING REQUIRED	

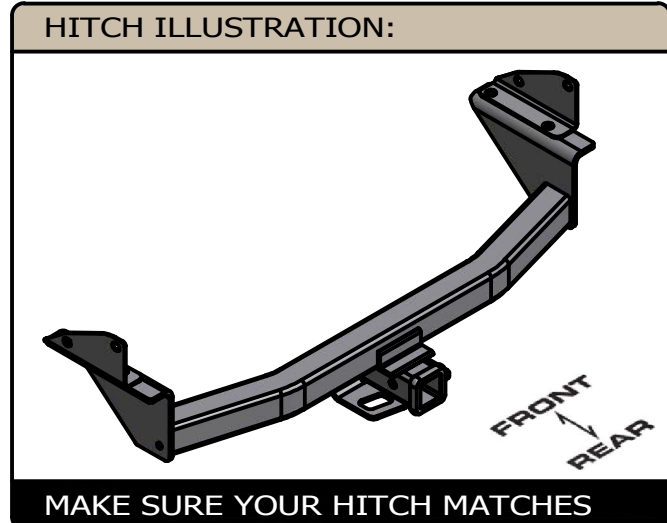

SCAN FOR MORE INFO

PERIODICALLY CHECK THIS RECEIVER HITCH TO ENSURE ALL FASTENERS ARE TIGHT AND ALL STRUCTURAL COMPONENTS ARE SOUND
 CURT Manufacturing LLC. warrants this product to be free of defects in material and/or workmanship at the time of retail purchase by the original purchaser. If the product is found to be defective, CURT Manufacturing LLC. may repair or replace the product at their option, when the product is returned, prepaid, with proof of purchase. Alteration to, misuse of, or improper installation of this product voids the warranty. CURT Manufacturing LLC.'s liability is limited to repair or replacement of products found to be defective, and specifically excludes liability for incidental or consequential loss or damage. For more information log onto www.curtmfg.com, & for helpful towing tips log onto www.hitchinfo.com

INSTALLATION WALKTHROUGH:

NOTE: REUSE FACTORY MOUNTING HARDWARE

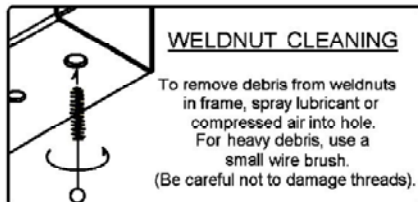
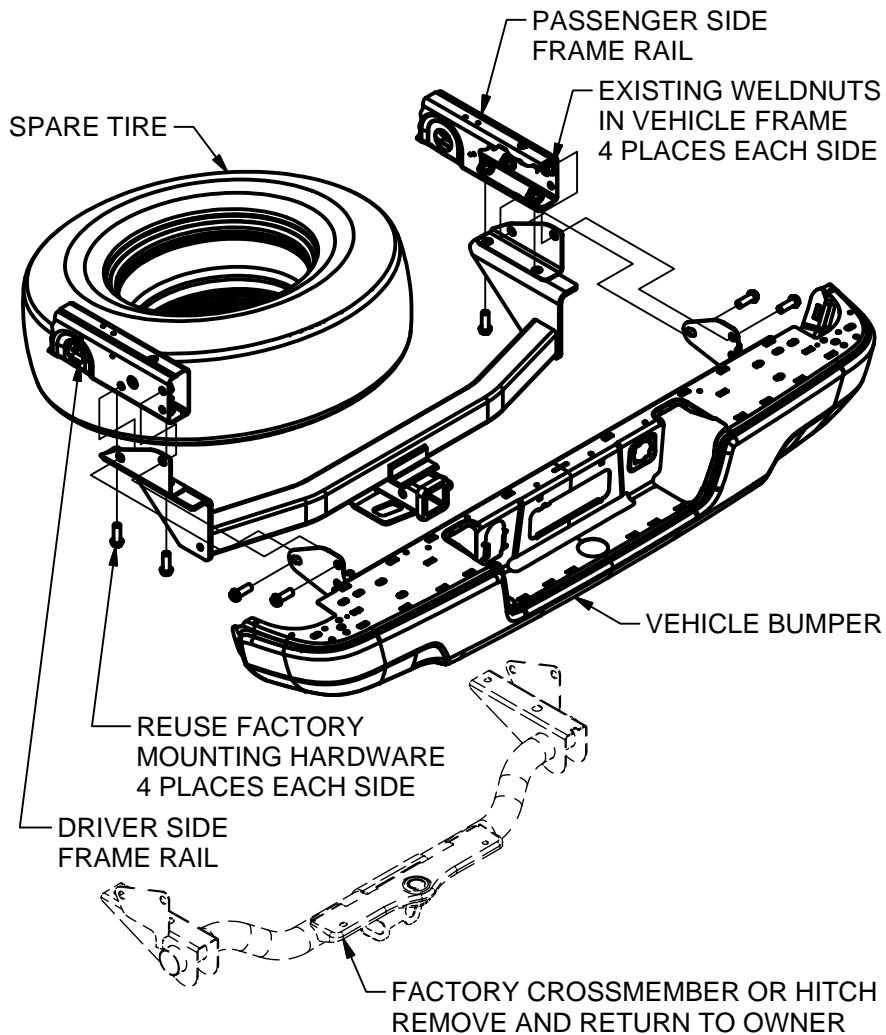

FRONT
↓
REAR

- 1.) Lower spare tire using the vehicle service tools located in the cab of the truck. Remove the center bracket by removing (4) bolts with a 13mm socket. Return bracket and hardware to customer and raise spare tire back into position.

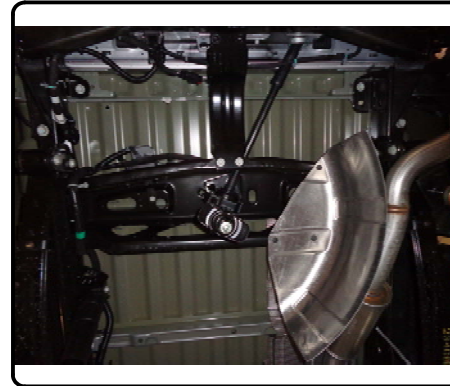

- 2.) Remove (4) bolts securing the factory crossmember or hitch to the frame rail with a 21mm socket. Set hardware aside for reuse during CURT hitch installation. Note: The bumper shares the same mounting points and should be supported from underneath.

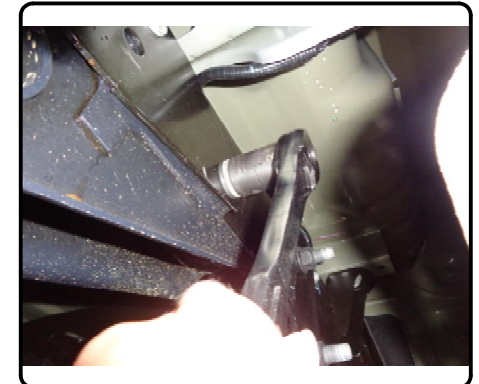
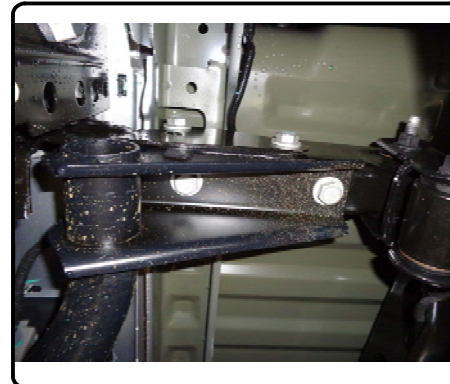

INSTALLATION WALKTHROUGH:

3.) Check to be sure that all wiring clears and slowly pull factory crossmember or hitch downward and remove from vehicle. Clean weldnuts as needed with lubricant and brush. Replace with CURT hitch, which will mount in the space between the frame and the bumper mounting plates.



4.) Using the existing mounting hardware, attach the bottom mounting bolts (2 places each side) and loosely secure so that bumper placement adjustments can be made. Adjust bumper position to align with side mounting holes and secure remaining (4) bolts with a 21mm socket.



5.) Torque all M14 bolts to 100 ft-lbs.

Installation complete



13176

CHEVROLET COLORADO & GMC CANYON

10/16/2014

GROSS LOAD CAPACITY WHEN USED AS A WEIGHT CARRYING HITCH: 8,000 LBS. TRAILER WEIGHT & 800 LBS. TONGUE WEIGHT.
GROSS LOAD CAPACITY WHEN USED AS A WEIGHT DISTRIBUTION HITCH: 10,000 LBS. TRAILER WEIGHT & 1,000 LBS. TONGUE WEIGHT

DO NOT EXCEED VEHICLE MANUFACTURER'S RECOMMENDED TOWING CAPACITY.

HAVING INSTALLATION QUESTIONS? CALL TECHNICAL SUPPORT AT 1-800-798-0813

NOTE: REUSE FACTORY MOUNTING HARDWARE

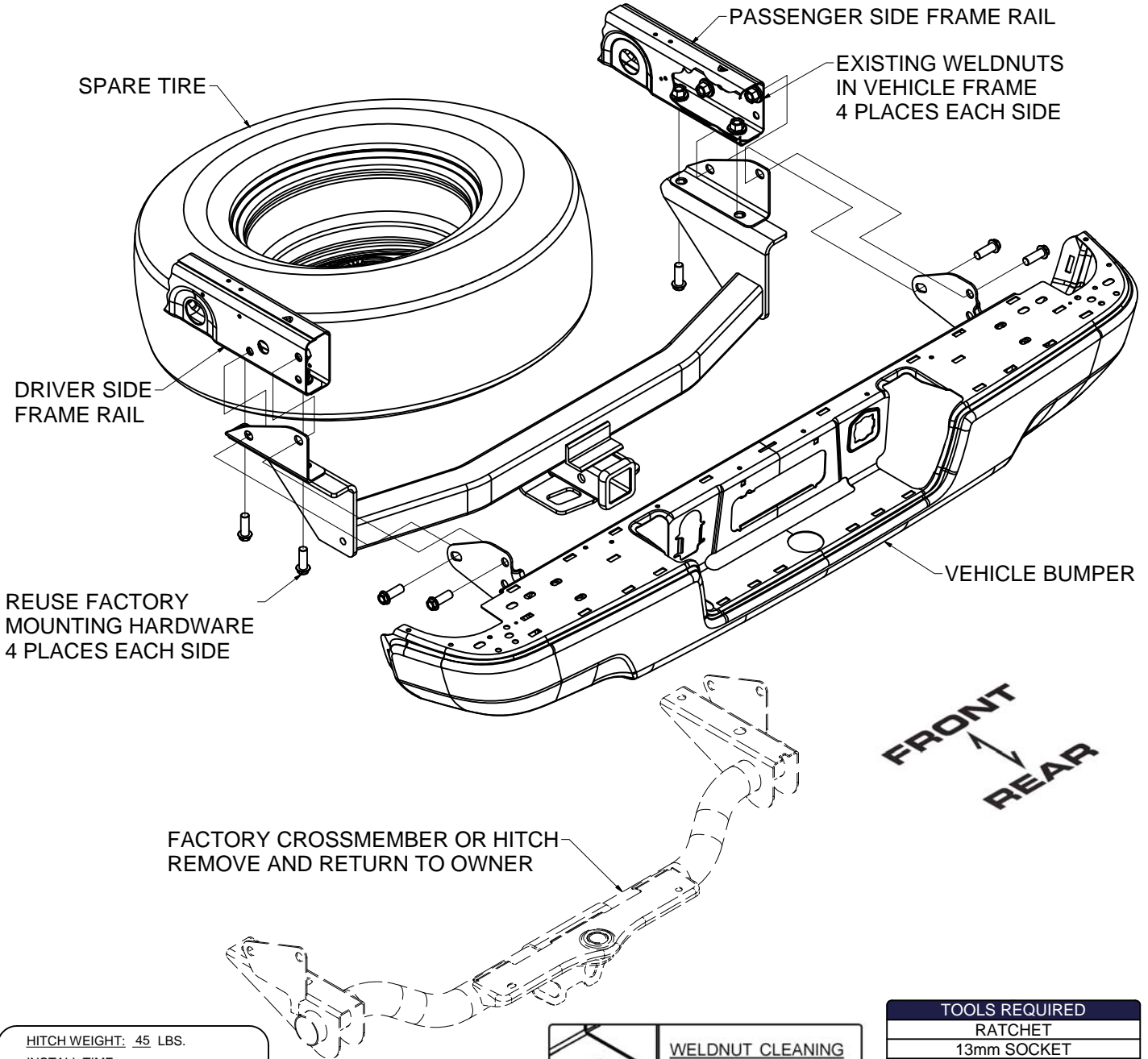

HITCH WEIGHT: 45 LBS.
INSTALL TIME
 PROFESSIONAL: 30 MINUTES
 NOVICE (DIY): 60 MINUTES
INSTALL NOTES:
 -LOWER SPARE TIRE
 -REMOVE FACTORY COMPONENTS
 -WELDNUT CLEANING
 -NO DRILLING REQUIRED

WELDNUT CLEANING

To remove debris from weldnuts in frame, spray lubricant or compressed air into hole. For heavy debris, use a small wire brush. (Be careful not to damage threads).

TOOLS REQUIRED
RATCHET
13mm SOCKET
21mm SOCKET
9" EXTENSION
JACK STANDS
SPRAY LUBRICANT
WIRE PIPE BRUSH
TORQUE WRENCH



Scan for more information

PERIODICALLY CHECK THIS RECEIVER HITCH TO ENSURE THAT ALL FASTENERS ARE TIGHT AND THAT ALL STRUCTURAL COMPONENTS ARE SOUND.

CURT Manufacturing LLC., warrants this product to be free of defects in material and/or workmanship at the time of retail purchase by the original purchaser. If the product is found to be defective, CURT Manufacturing LLC., may repair or replace the product, at their option, when the product is returned, prepaid, with proof of purchase. Alteration to, misuse of, or improper installation of this product voids the warranty. CURT Manufacturing LLC.'s liability is limited to repair or replacement of products found to be defective, and specifically excludes liability for incidental or consequential loss or damage.

INSTALLATION STEPS

- 1.) Lower spare tire using the vehicle service tools located in the cab of the truck. Remove the center bracket by removing (4) bolts with a 13mm socket. Return bracket and hardware to customer and raise spare tire back into position.
- 2.) Remove (4) bolts securing the factory crossmember or hitch to the frame rail with a 21mm socket. Set hardware aside for reuse during CURT installation.

Note: The bumper shares the same mounting points and should be supported from underneath.
- 3.) Check to be sure that all wiring clears and slowly pull factory crossmember or hitch downward and remove from vehicle. Clean weldnuts as needed with lubricant and brush. Replace with CURT hitch, which will mount in the space between the frame and the bumper mounting plates.
- 4.) Using the existing mounting hardware, attach the bottom mounting bolts (2 places each side) and loosely secure so that bumper placement adjustments can be made. Adjust bumper position to align with side mounting holes and secure remaining (4) bolts with a 21mm socket.
- 5.) Torque all M14 bolts to 100 ft-lbs.

Installation Complete

PERIODICALLY CHECK THIS RECEIVER HITCH TO ENSURE THAT ALL FASTENERS ARE TIGHT AND THAT ALL STRUCTURAL COMPONENTS ARE SOUND.