



13182 INSTALLATION INSTRUCTIONS

! Safety glasses should be worn at all times while installing this product.

YEARS: 2011-CURRENT

MAKE: DODGE, JEEP

MODEL: DURANGO, GRAND CHEROKEE

STYLE: SUV

WARNING: NEVER EXCEED YOUR VEHICLE MANUFACTURER'S RECOMMENDED TOWING CAPACITY

WEIGHT CARRYING:
TRAILER WEIGHT: 5,000 LBS.
TONGUE WEIGHT: 500 LBS.

WEIGHT DISTRIBUTION:
TRAILER WEIGHT: 7,500 LBS.
TONGUE WEIGHT: 750 LBS.

INSTALLATION TIME: 10 MIN.

THE INSTALL TIME LISTED IS FOR PROFESSIONAL INSTALLERS. IF YOU ARE HESITANT TO UNDERTAKE THIS TASK ON YOUR OWN, CONTACT AN AUTHORIZED CURT INSTALLER FOR ADDITIONAL ASSISTANCE.



INSTALLATION TIPS:

1. BEFORE YOU BEGIN INSTALLATION, READ ALL INSTRUCTIONS THOROUGHLY.
2. TO EASE INSTALLATION, 2 PEOPLE MAY BE REQUIRED.
3. USING PROPER TOOLS WILL GREATLY IMPROVE THE QUALITY OF THE INSTALL AND REDUCE THE TIME REQUIRED.
4. NEED HELP OR HAVE SOME QUESTIONS? CALL TECHNICAL SUPPORT AT 800.798.0813

INSTALLATION REQUIRES:

 RATCHET	 21mm SOCKET	 TORQUE WRENCH
 UTILITY KNIFE	 SAFETY GLASSES	

LEVEL OF DIFFICULTY: EASY

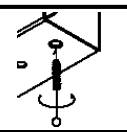
EASY	MODERATE	CHALLENGING
	NO DRILLING REQUIRED	
	TRIMMING OF EXCESS CAULK MAY BE REQUIRED	
	WELDNUT CLEANING MAY BE REQUIRED	

VEHICLE PHOTO:



REPRESENTATIVE PHOTO

HITCH ILLUSTRATION:

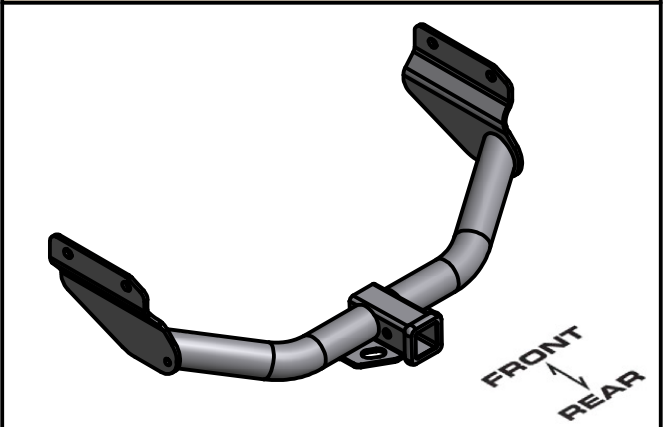

MAKE SURE YOUR HITCH MATCHES

PERIODICALLY CHECK THIS RECEIVER HITCH TO ENSURE ALL FASTENERS ARE TIGHT AND ALL STRUCTURAL COMPONENTS ARE SOUND

CURT Manufacturing LLC. warrants this product to be free of defects in material and/or workmanship at the time of retail purchase by the original purchaser. If the product is found to be defective, Curt Manufacturing LLC. may repair or replace the product at their option, when the product is returned, prepaid, with proof of purchase. Alteration to, misuse of, or improper installation of this product voids the warranty. Curt Manufacturing LLC.'s liability is limited to repair or replacement of products found to be defective, and specifically excludes liability for incidental or consequential loss or damage.

For more information log onto www.curtmfg.com, & for helpful towing tips log onto www.hitchinfo.com

INSTALLATION WALKTHROUGH:

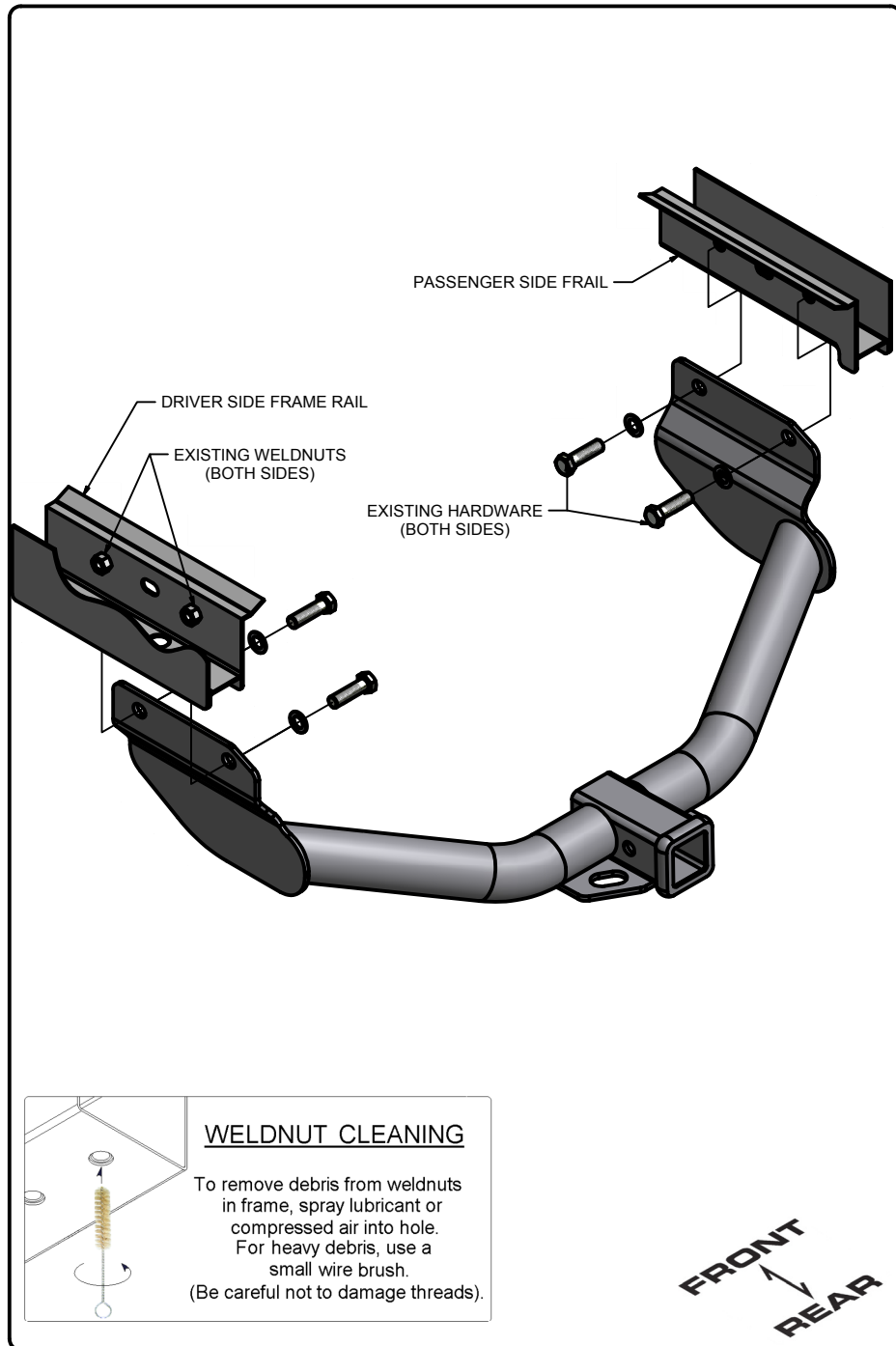

1. Remove (4) existing M14 bolts. These bolts will be used for hitch installation.

Note: If factory tow loop is present you will need to remove it prior to install. Trim excess caulk on vehicle frame rails if it interferes with hitch installation.

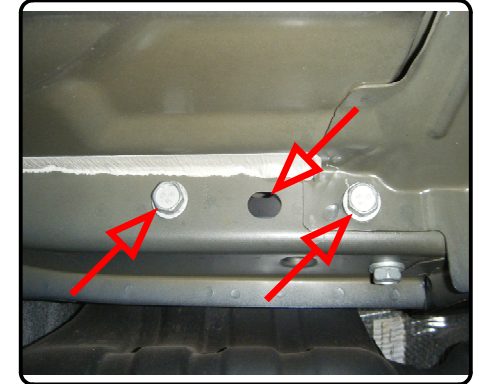

2. Raise hitch into position and reinstall (4) M14 bolts. Torque all M14 hardware to 105 ft-lbs.

Install is complete.

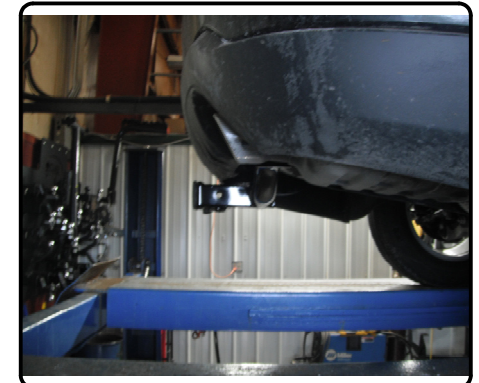

13182

DODGE DURANGO, JEEP GRAND CHEROKEE

10/24/2011

GROSS LOAD CAPACITY WHEN USED AS A WEIGHT CARRYING HITCH: 5,000 LBS. TRAILER WEIGHT & 500 LBS. TONGUE WEIGHT.
GROSS LOAD CAPACITY WHEN USED AS A WEIGHT DISTRIBUTION HITCH: 7,500 LBS. TRAILER WEIGHT & 750 LBS. TONGUE WEIGHT

DO NOT EXCEED VEHICLE MANUFACTURER'S RECOMMENDED TOWING CAPACITY.

HAVING INSTALLATION QUESTIONS? CALL TECHNICAL SUPPORT AT 1-800-798-0813

TOOLS REQUIRED
RATCHET
21mm SOCKET
TORQUE WRENCH
UTILITY KNIFE

INSTALLED HITCH POSITION

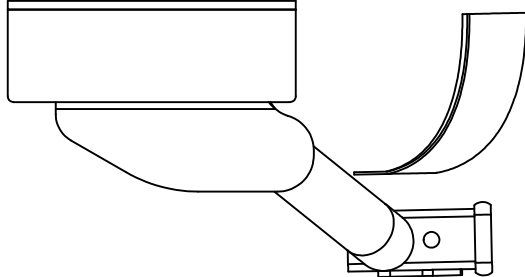

PASSENGER SIDE FRAME RAIL

DRIVER SIDE FRAME RAIL

EXISTING WELDNUTS (BOTH SIDES)

EXISTING HARDWARE (BOTH SIDES)

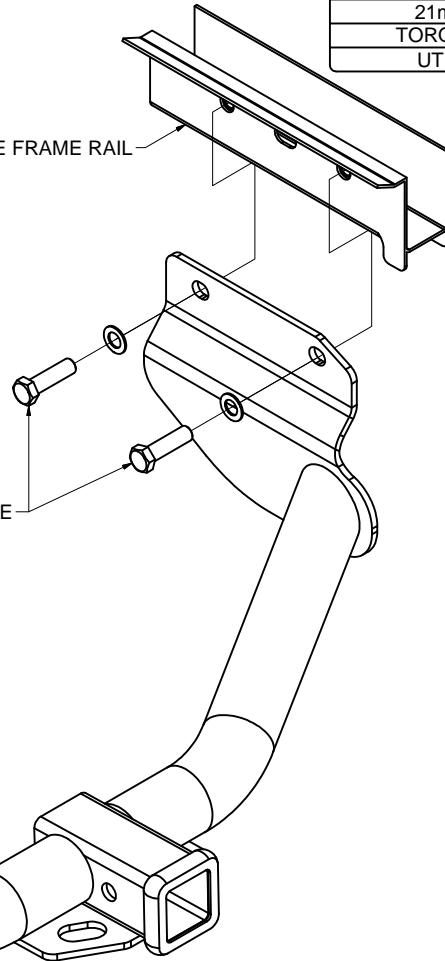
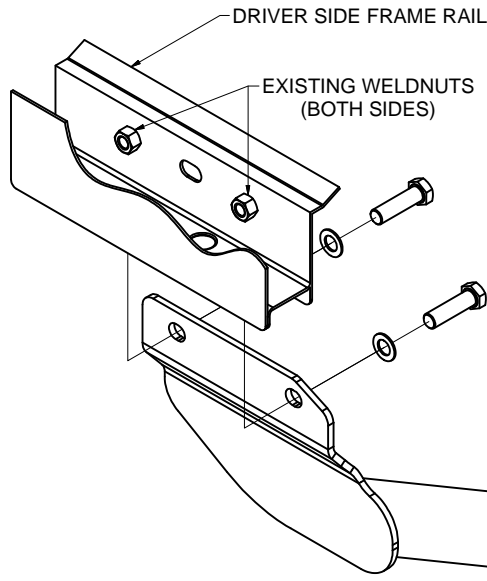

HITCH WEIGHT: 30 LBS.

INSTALL TIME

PROFESSIONAL: 10 MINUTES

NOVICE (DIY): 20 MINUTES

INSTALL NOTES:

- NO DRILLING REQUIRED

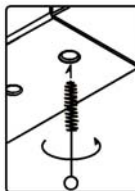

WELDNUT CLEANING

To remove debris from weldnuts in frame, spray lubricant or compressed air into hole. For heavy debris, use a small wire brush. (Be careful not to damage threads.)

FRONT
↑
REAR

INSTALLATION STEPS

Note: If factory tow loop is present you will need to remove it prior to install.

1. Remove (4) existing M14 bolts. These bolts will be used for hitch installation.
2. Raise hitch into position and reinstall (4) M14 bolts. Note: Trim excess caulk on vehicle frame rails if it interferes with hitch installation.
3. Tighten all M14 hardware to 105 ft-lbs.

PERIODICALLY CHECK THIS RECEIVER HITCH TO ENSURE THAT ALL FASTENERS ARE TIGHT AND THAT ALL STRUCTURAL COMPONENTS ARE SOUND.

Curt Manufacturing Inc., warrants this product to be free of defects in material and/or workmanship at the time of retail purchase by the original purchaser. If the product is found to be defective, Curt Manufacturing Inc., may repair or replace the product, at their option, when the product is returned, prepaid, with proof of purchase. Alteration to, misuse of, or improper installation of this product voids the warranty. Curt Manufacturing Inc.'s liability is limited to repair or replacement of products found to be defective, and specifically excludes liability for incidental or consequential loss or damage.