



Safety glasses should be worn at all times while installing this product.

YEARS: 2014

MAKE: MERCEDES-BENZ

MODEL: GL450, GL550 EXCLUDES Active Curve Sys.

STYLE: SUV

WARNING: NEVER EXCEED YOUR VEHICLE MANUFACTURER'S RECOMMENDED TOWING CAPACITY

WEIGHT CARRYING:
 TRAILER WEIGHT: 7,500 LBS.
 TONGUE WEIGHT: 900 LBS.

WEIGHT DISTRIBUTION:
 TRAILER WEIGHT: N/A LBS.
 TONGUE WEIGHT: N/A LBS.

PRO INSTALL TIME: 40 MIN.
NOVICE INSTALL TIME: 80 MIN.

IF YOU ARE HESITANT TO UNDERTAKE THIS TASK ON YOUR OWN, CONTACT AN AUTHORIZED CURT INSTALLER FOR ADDITIONAL ASSISTANCE.

INSTALLATION TIPS:

- BEFORE YOU BEGIN INSTALLATION, READ ALL INSTRUCTIONS THOROUGHLY.
- TO EASE INSTALLATION, 2 PEOPLE MAY BE REQUIRED.
- USING PROPER TOOLS WILL GREATLY IMPROVE THE QUALITY OF THE INSTALL AND REDUCE THE TIME REQUIRED.
- NEED HELP OR HAVE SOME QUESTIONS? CALL TECHNICAL SUPPORT AT 800.798.0813



INSTALLATION REQUIRES:

		8mm 10mm 13mm 3/4"
TORXBIT T-40 SOCKET	6" SOCKET EXTENSION	

LEVEL OF DIFFICULTY: MODERATE

EASY	MODERATE	CHALLENGING
	- NO DRILLING REQUIRED	
	- LOWER EXHAUST	
	- TRIM HEAT SHIELD - TRIM FASCIA TABS	
	- TEMPORARY PART REMOVAL	

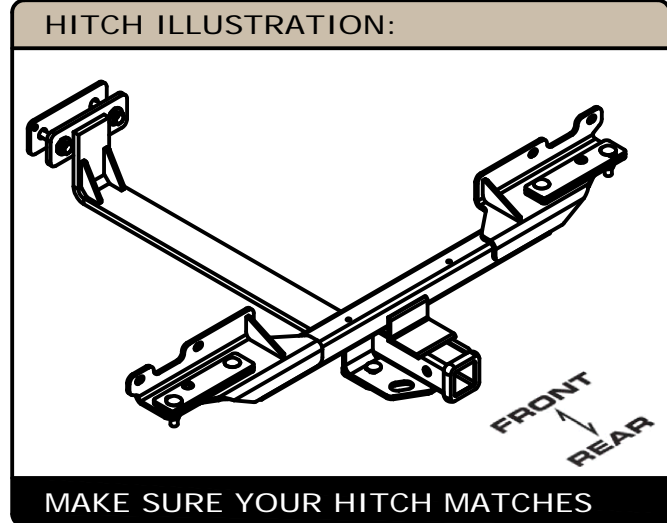

PERIODICALLY CHECK THIS RECEIVER HITCH TO ENSURE ALL FASTENERS ARE TIGHT AND ALL STRUCTURAL COMPONENTS ARE SOUND CURT Manufacturing LLC. warrants this product to be free of defects in material and/or workmanship at the time of retail purchase by the original purchaser. If the product is found to be defective, Curt Manufacturing LLC. may repair or replace the product at their option, when the product is returned, prepaid, with proof of purchase. Alteration to, misuse of, or improper installation of this product voids the warranty. Curt Manufacturing LLC.'s liability is limited to repair or replacement of products found to be defective, and specifically excludes liability for incidental or consequential loss or damage.

For more information log onto www.curtmfg.com, & for helpful towing tips log onto www.hitchinfo.com

INSTALLATION WALKTHROUGH:

Parts List			
ITEM	QTY	PART NUMBER	DESCRIPTION
1	2	1/2	CONICAL TOOTHED WASHER
2	2	1/2-13 x 1	CARRIAGE BOLT
3	4	1/2 - 13 x 2", GR8	CARRIAGE BOLT, GR8
4	2	1/2-13 x 3	HEX BOLT
5	2	11120497	.344" X .813" BLACK NYLON TRIM PANEL RETAINER
6	2	3/8"	CONICAL TOOTHED WASHER
7	6	HFN 1213	HEX FLANGE NUT
8	2	M8 - 1.25 x 30 HEX BOLT	HEX HEAD BOLT

Parts List			
ITEM	QTY	PART NUMBER	DESCRIPTION
A	1	13190-WA	HITCH WELDMENT ASSEMBLY
B	1	13190-MSWA	MOUNTING STRAP WELDMENT ASSEMBLY
C	1	13190-NPA	NUT PLATE ASSEMBLY
D	2	13190-BP	.250" BOLT PLATE
E	2	13190-SP	.250" SPACER PLATE

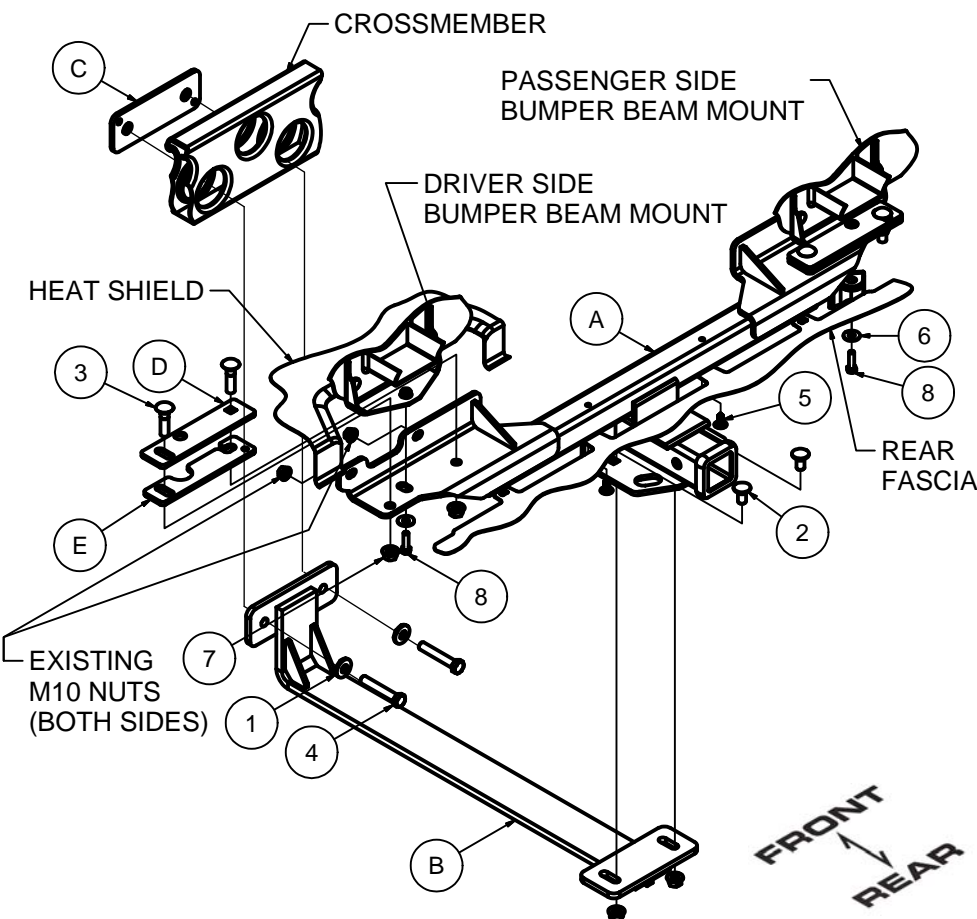

CONICAL TOOTHED WASHER ORIENTATION DIAGRAM

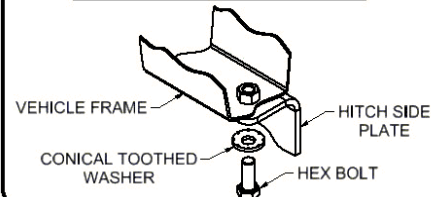

RUBBER ISOLATOR REMOVAL DIAGRAM

This technique can be used if an Exhaust Hanger Removal Pliers is not available.

Using a 5/8" open end wrench, slide the wrench up to the rubber isolator, cradling the hanger rod as shown. Next place the flat edge of a pry bar between the wrench and the hanger stop or hanger rod. Then simply rotate the pry bar toward the wrench to remove the rubber isolator.

Note: Using a spray lubricant or soapy water on the hanger rod and the rubber isolator helps removal.

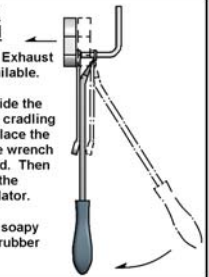

1. Remove the bumper fascia tabs by removing (3) bolts using a 10mm socket to remove center support bracket. Remove exhaust tips using a T-40 Torx bit (2 each side).



INSTALLATION WALKTHROUGH:

2. Lower the exhaust for ease of assembly and heat shield trimming. Remove the rubber isolator (one each side) from the hanger attached to the vehicle. Spray lubricant may assist isolator removal. Support exhaust to prevent damage.



3. Disconnect heat shield bolts for trimming and hardware access. Remove (1) bolt from each side near the frame flange with an 8mm socket.



4. Trimming: Use shears or rotary cut-off wheel
Heat shield: Trim approx. 11" x 6" area as shown following the curvature of the heat shield.
Fascia tab: The outboard tabs on each side of the vehicle will need to be removed.

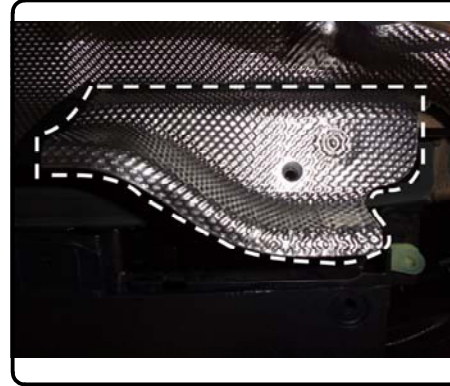

5. Remove the lower (2) nuts securing the bumper beam to the vehicle with a 10mm socket, both sides. Save for reassembly.



INSTALLATION WALKTHROUGH:

6. Raise hitch (A) into position and secure to the bumper beam studs using the vehicle nuts removed in Step (5).

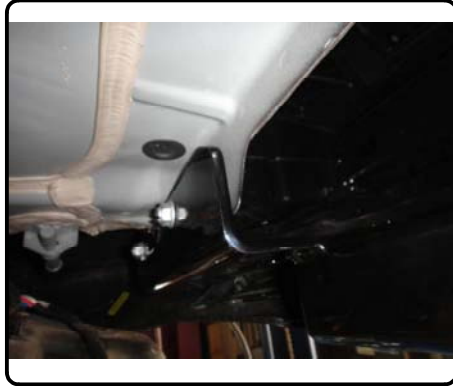

7. Stack bolt plate (D) on spacer plate (E) and run 1/2-13 x 1 1/2" carriage bolts through plate holes. Place plate assembly over the bumper beam tab and align with the holes in the hitch. Secure using 1/2-13 flange nuts, as shown.

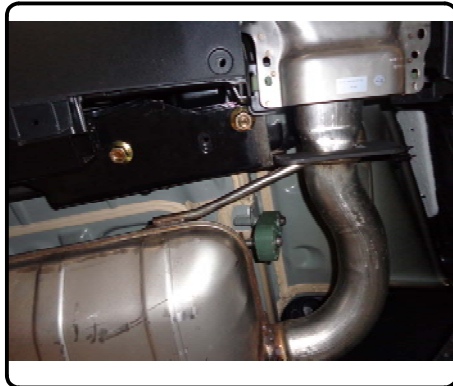

8. Center the holes of the hitch with the bumper beam tab weldnuts and secure with M8 bolts. Torque all M8 fasteners to 25 ft-lbs.
Torque all installed 1/2" fasteners to 110 ft-lbs.

Raise and secure the exhaust lowered in Step (2).



9. Raise mounting strap (B) into position and loosely secure to hitch 1/2-13 x 1" carriage bolts and 1/2-13 hex flange nuts. Raise nut plate (C) into position and secure mounting strap to the cross member using 1/2-13 x 3" hex bolts and 1/2" conical toothed washers.

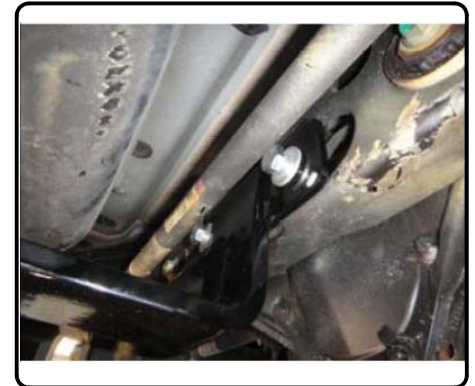

INSTALLATION WALKTHROUGH:

10. Torque all remaining 1/2" hardware to 110 ft-lbs.

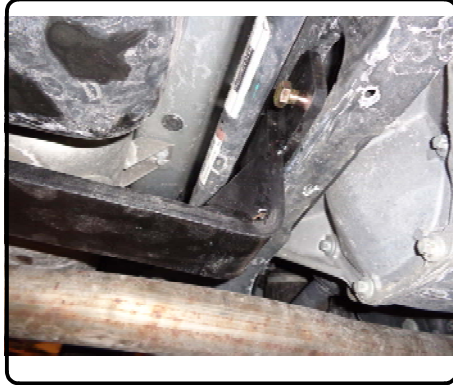
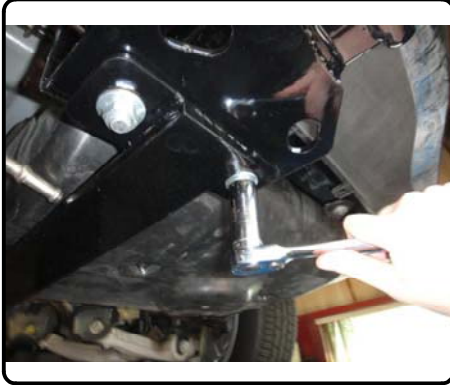

INSTALLATION COMPLETE

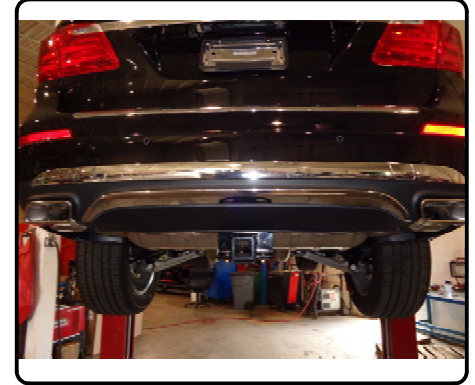
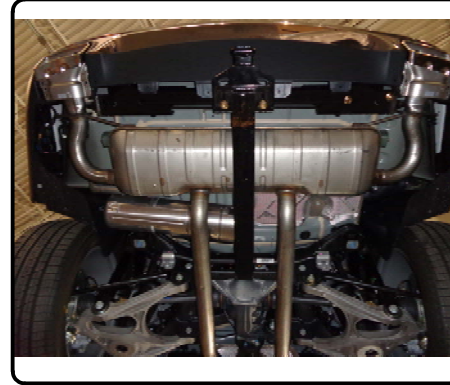

11. Secure the (2) center fascia tabs by pushing the nylon retainer clips into the holes in hitch tube.
Note: Some models may require enlargement of the fascia tab hole for nylon clip.



13190

MERCEDES-BENZ GL450 & GL550

Excluding Active Curve System

7/23/2014

GROSS LOAD CAPACITY WHEN USED AS A WEIGHT CARRYING HITCH: 7,500 LBS. TRAILER WEIGHT & 900 LBS. TONGUE WEIGHT. GROSS LOAD CAPACITY WHEN USED AS A WEIGHT DISTRIBUTION HITCH: N/A LBS. TRAILER WEIGHT & N/A LBS. TONGUE WEIGHT

DO NOT EXCEED VEHICLE MANUFACTURER'S RECOMMENDED TOWING CAPACITY.

HAVING INSTALLATION QUESTIONS? CALL TECHNICAL SUPPORT AT 1-800-798-0813

Hardware List			
ITEM	QTY	PART NUMBER	DESCRIPTION
1	2	1/2	CONICAL TOOTHED WASHER
3	4	1/2 - 13 x 2", GR8	CARRIAGE BOLT, GR8
2	2	1/2-13 x 1	CARRIAGE BOLT
4	2	1/2-13 x 3	HEX BOLT
5	2	11120497	.344" X .813" BLACK NYLON TRIM PANEL RETAINER
6	2	3/8"	CONICAL TOOTHED WASHER
7	6	HFN 1213	HEX FLANGE NUT
8	2	M8 - 1.25 x 30 HEX BOLT	HEX HEAD BOLT

Parts List			
ITEM	QTY	PART NUMBER	DESCRIPTION
A	1	13190-WA	HITCH WELDMENT ASSEMBLY
B	1	13190-MSWA	MOUNTING STRAP WELDMENT ASSEMBLY
C	1	13190-NPA	NUT PLATE ASSEMBLY
D	2	13190-BP	.250" BOLT PLATE
E	2	13190-SP	.250" SPACER PLATE

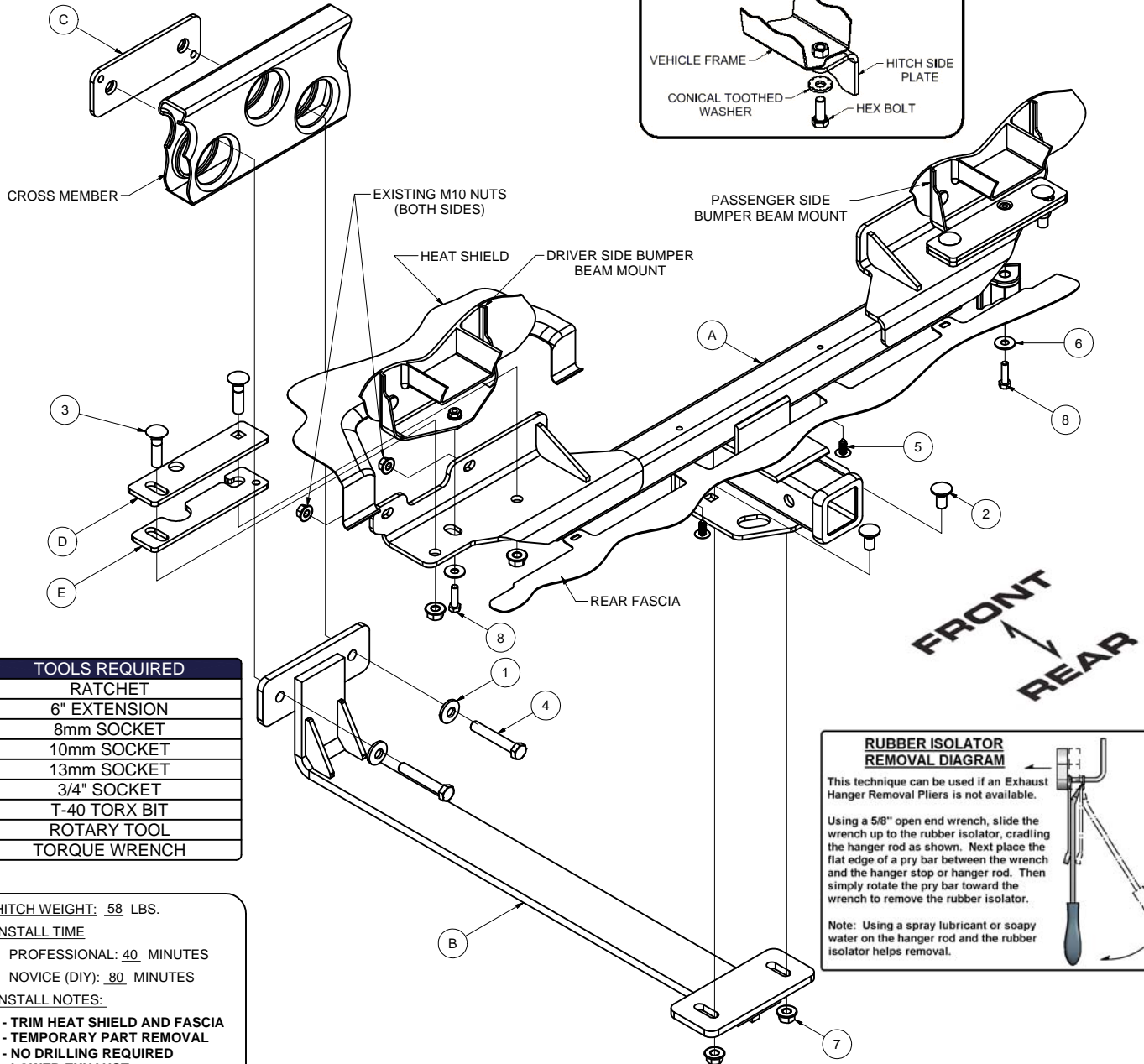
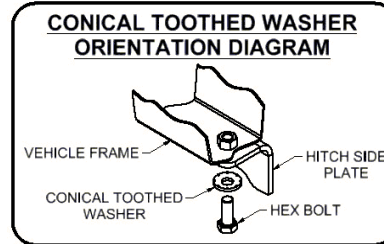

TOOLS REQUIRED
RATCHET
6" EXTENSION
8mm SOCKET
10mm SOCKET
13mm SOCKET
3/4" SOCKET
T-40 TORX BIT
ROTARY TOOL
TORQUE WRENCH

HITCH WEIGHT: 58 LBS.
 INSTALL TIME
 PROFESSIONAL: 40 MINUTES
 NOVICE (DIY): 80 MINUTES
 INSTALL NOTES:
 - TRIM HEAT SHIELD AND FASCIA
 - TEMPORARY PART REMOVAL
 - NO DRILLING REQUIRED
 - LOWER EXHAUST

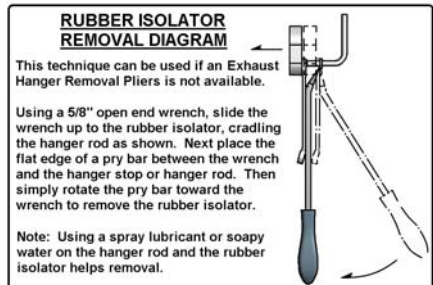

PERIODICALLY CHECK THIS RECEIVER HITCH TO ENSURE THAT ALL FASTENERS ARE TIGHT AND THAT ALL STRUCTURAL COMPONENTS ARE SOUND.



Curt Manufacturing LLC., warrants this product to be free of defects in material and/or workmanship at the time of retail purchase by the original purchaser. If the product is found to be defective, Curt Manufacturing LLC., may repair or replace the product, at their option, when the product is returned, prepaid, with proof of purchase. Alteration to, misuse of, or improper installation of this product voids the warranty. Curt Manufacturing LLC.'s liability is limited to repair or replacement of products found to be defective, and specifically excludes liability for incidental or consequential loss or damage.

13190**MERCEDES-BENZ GL450 & GL550**

Excluding Active Curve System

GROSS LOAD CAPACITY WHEN USED AS A WEIGHT CARRYING HITCH: 7,500 LBS. TRAILER WEIGHT & 900 LBS. TONGUE WEIGHT.
 GROSS LOAD CAPACITY WHEN USED AS A WEIGHT DISTRIBUTION HITCH: N/A LBS. TRAILER WEIGHT & N/A LBS. TONGUE WEIGHT

DO NOT EXCEED VEHICLE MANUFACTURER'S RECOMMENDED TOWING CAPACITY.

HAVING INSTALLATION QUESTIONS? CALL TECHNICAL SUPPORT AT 1-800-798-0813

HEAT SHIELD TRIM

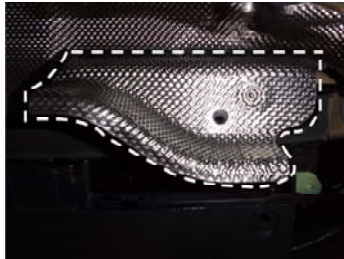

FASCIA TAB TRIM

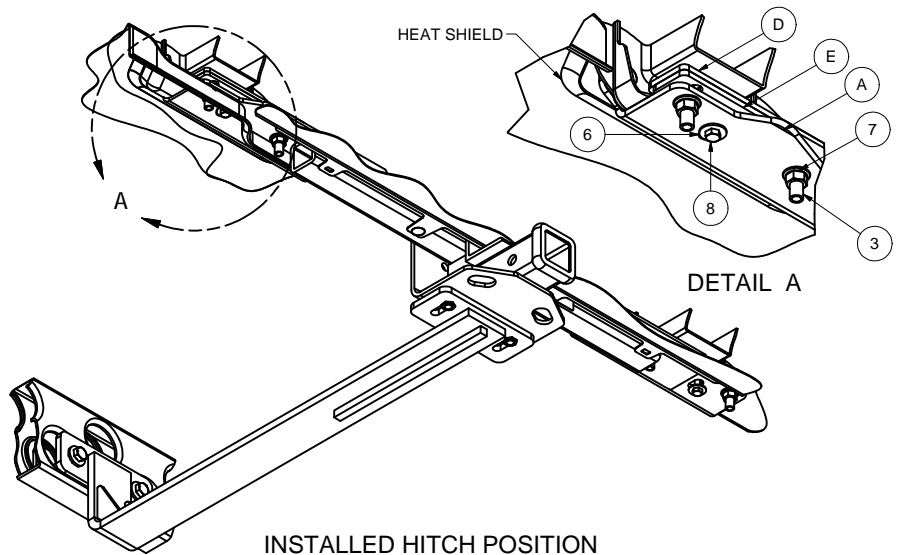

INSTALLATION STEPS

1. Remove the bumper fascia tabs by removing (3) bolts using a 10mm socket to remove center support bracket. Remove exhaust tips using a T-40 Torx bit (2 each side).
 2. Lower the exhaust for ease of assembly and heat shield trimming. Remove the rubber isolator (one each side) from the hanger attached to the vehicle. Spray lubricant may assist isolator removal. Support exhaust to prevent damage.
 3. Disconnect heat shield bolts for trimming and hardware access. Remove (1) bolt from each side near the frame flange with an 8mm socket.
 4. Trimming: Use shears or a rotary cut-off wheel.
Heat shield: Trim approx. 11" x 6" area as shown (Heat Shield Trim Diagram) following the curvature of the heat shield.
Fascia tab: The outboard tabs on each side of the vehicle will need to be removed. (Fascia Tab Trim Diagram)
 5. Remove the lower (2) nuts securing the bumper beam to the vehicle with a 10mm socket, both sides. Save for reassembly.
 6. Raise hitch (A) into position and secure to the bumper beam studs using the vehicle nuts removed in Step (5).
 7. Stack bolt plate (D) on spacer plate (E) and run 1/2-13 x 1 1/2" carriage bolts through plate holes. Place plate assembly over the bumper beam tab and align with the holes in the hitch. Secure using 1/2-13 flange nuts, as shown.
 8. Center the holes of the hitch with the bumper beam tab weldnuts and secure with M8 bolts. Torque all M8 fasteners to 25 ft-lbs. Torque all installed 1/2" fasteners to 110 ft-lbs.
- Raise and secure the exhaust lowered in Step (2).
9. Raise mounting strap (B) into position and loosely secure to hitch 1/2-13 x 1" carriage bolts and 1/2-13 hex flange nuts. Raise nut plate (C) into position and secure mounting strap to the cross member using 1/2-13 x 3" hex bolts and 1/2" conical toothed washers.
 10. Torque all remaining 1/2" hardware to 110 ft-lbs.
 11. Secure the (2) center fascia tabs by pushing the nylon retainer clips into the holes in hitch tube.
Note: Some models may require enlargement of the fascia tab hole for nylon clip.

PERIODICALLY CHECK THIS RECEIVER HITCH TO ENSURE THAT ALL FASTENERS ARE TIGHT AND THAT ALL STRUCTURAL COMPONENTS ARE SOUND.

Curt Manufacturing LLC., warrants this product to be free of defects in material and/or workmanship at the time of retail purchase by the original purchaser. If the product is found to be defective, Curt Manufacturing LLC., may repair or replace the product, at their option, when the product is returned, prepaid, with proof of purchase. Alteration to, misuse of, or improper installation of this product voids the warranty. Curt Manufacturing LLC.'s liability is limited to repair or replacement of products found to be defective, and specifically excludes liability for incidental or consequential loss or damage.