

13198**TOYOTA TUNDRA**

6/29/2009

GROSS LOAD CAPACITY WHEN USED AS A WEIGHT CARRYING HITCH: 6,000 LBS. TRAILER WEIGHT & 600 LBS. TONGUE WEIGHT.
 GROSS LOAD CAPACITY WHEN USED AS A WEIGHT DISTRIBUTION HITCH: 8,000 LBS. TRAILER WEIGHT & 800 LBS. TONGUE WEIGHT

*****DO NOT EXCEED VEHICLE MANUFACTURER'S RECOMMENDED TOWING CAPACITY.*****

Parts List			
ITEM	QTY	PART NUMBER	DESCRIPTION
1	2	1/2-13 x 1 3/4	HEX BOLT
2	2	CM-SP12	.250 x 1.00 x 2.00" SQUARE HOLE SPACER
3	2	HFN 1213	HEX FLANGE NUT
4	4	1/2"	CONICAL TOOTHED WASHER
5	4	M12 - 1.25 x 40 HEX	HEX BOLT
6	4	M14-2 x 40mm LG.	HEX BOLT
7	4	5/8	WASHER
8	4	5_8 LOCK WASHER	HELICAL LOCK WASHER
9	4	M14 - 2 HEX NUT	HEX NUT

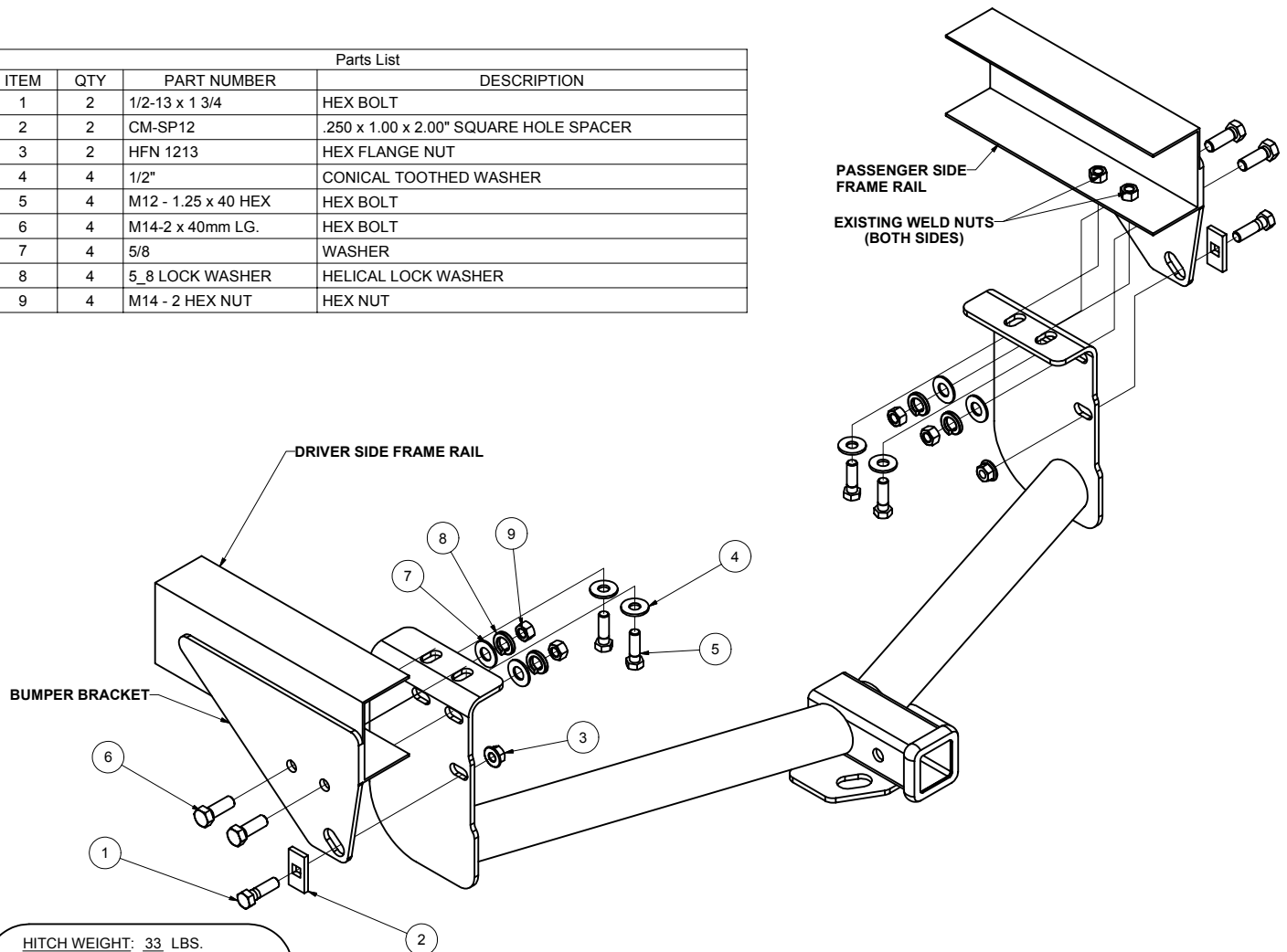

HITCH WEIGHT: 33 LBS.

INSTALL TIME

PROFESSIONAL: 30 MINUTES

NOVICE (DIY): 65 MINUTES

INSTALL NOTES:

- NO DRILLING REQUIRED
- REMOVE EXISTING BRACKET

INSTALLATION STEPS

- 1) Remove existing angle brackets from inside surface of frame rails and bumper brackets. (return brackets and fasteners to vehicle owner)
- 2) Raise hitch into position and install the 12mm bolts with conical tooth washers.
- 3) Install the 14mm fasteners then the 1/2" fasteners as shown above.
- 4) Torque all 1/2" fasteners to 75 lb-ft, all 12mm fasteners to 65 lb-ft, and all 14mm fasteners to 94 lb-ft.

PERIODICALLY CHECK THIS RECEIVER HITCH TO ENSURE THAT ALL FASTENERS ARE TIGHT AND THAT ALL STRUCTURAL COMPONENTS ARE SOUND.

Curt Manufacturing Inc., warrants this product to be free of defects in material and/or workmanship at the time of retail purchase by the original purchaser. If the product is found to be defective, Curt Manufacturing Inc., may repair or replace the product, at their option, when the product is returned, prepaid, with proof of purchase. Alteration to, misuse of, or improper installation of this product voids the warranty. Curt Manufacturing Inc.'s liability is limited to repair or replacement of products found to be defective, and specifically excludes liability for incidental or consequential loss or damage.