

13229 / RRH13229**DODGE DAKOTA & MITSUBISHI RAIDER****6/30/2009**

GROSS LOAD CAPACITY WHEN USED AS A WEIGHT CARRYING HITCH: 5,000 LBS. TRAILER WEIGHT & 500 LBS. TONGUE WEIGHT.
 GROSS LOAD CAPACITY WHEN USED AS A WEIGHT DISTRIBUTION HITCH: 5,500 LBS. TRAILER WEIGHT & 550 LBS. TONGUE WEIGHT

*****DO NOT EXCEED VEHICLE MANUFACTURER'S RECOMMENDED TOWING CAPACITY.*****

HAVING INSTALLATION QUESTIONS? CALL TECHNICAL SUPPORT AT 1-800-798-0813

Parts List			
ITEM	QTY	PART NUMBER	DESCRIPTION
1	1	3 4 - 10 x 2.75 FHSCS	FLAT HEAD SOCKET CAP SCREW, ZP
2	2	1/2-13 x 1 1/4	HEX BOLT
3	2	1/2"	WASHER WIDE
4	2	HFN 1213	HEX FLANGE NUT

TOOLS REQUIRED
RATCHET
TORQUE WRENCH
3/4" SOCKET
3/4" WRENCH
1/2" HEX BIT SOCKET

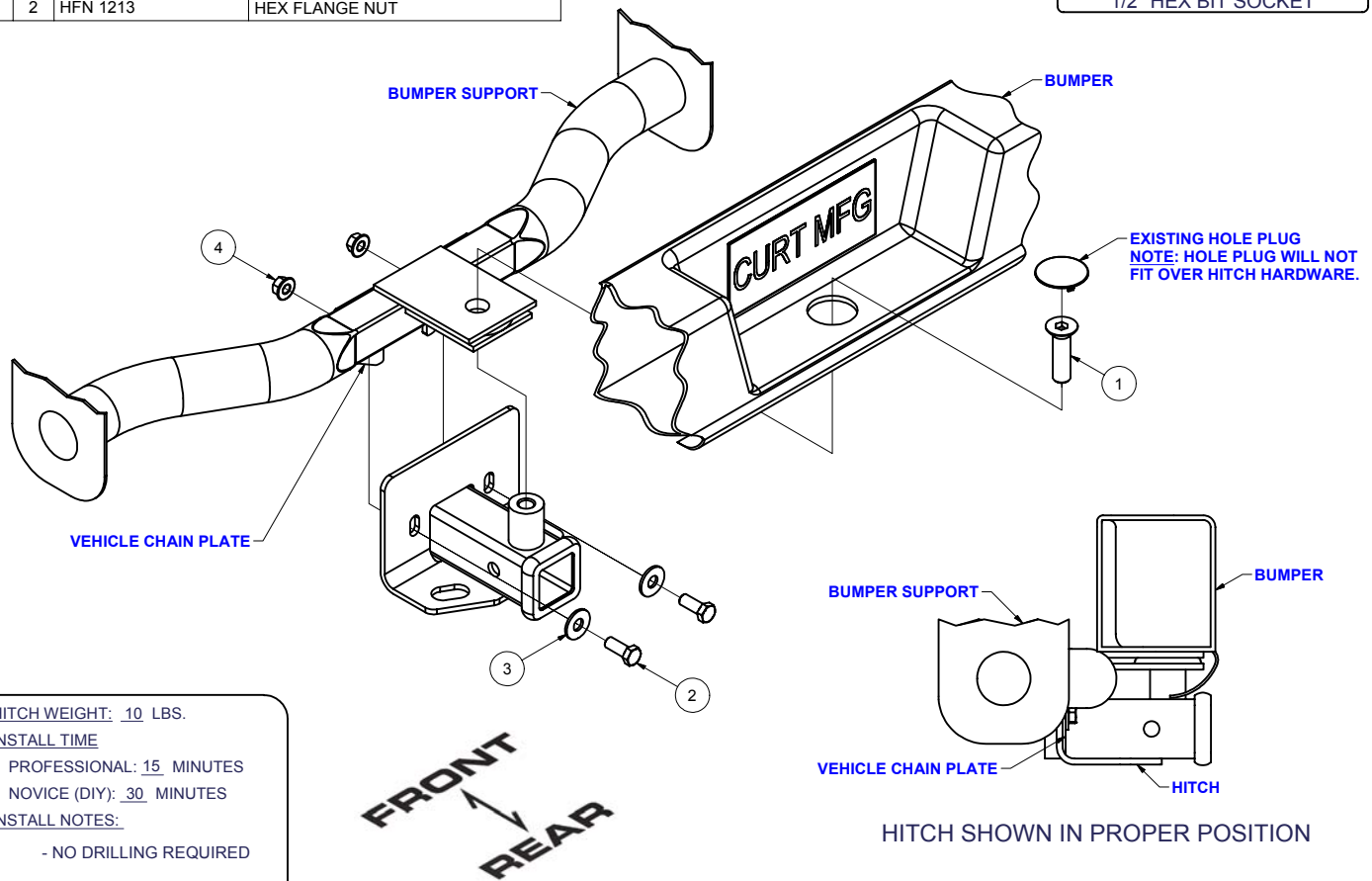

HITCH WEIGHT: 10 LBS.

INSTALL TIME

PROFESSIONAL: 15 MINUTES

NOVICE (DIY): 30 MINUTES

INSTALL NOTES:

- NO DRILLING REQUIRED

INSTALLATION STEPS

1. Remove existing hole plug (if present) on the center of bumper and return to vehicle owner.
2. Raise hitch into position by sliding the hitch chain plate behind the vehicle chain plate. Loosely secure hitch with 3/4-10 X 1 3/4" flat head socket cap screw through the bumper and bumper support and into the threaded hitch spacer. (Bolt will be tightened in Step 4)
3. Install 1/2-13 X 1 1/4" hex bolts and 1/2" washers through the slots in hitch and out the vehicle safety chain plate. Loosely Secure with 1/2" flange nuts. (Bolts will be tightened in Step 5)
4. Torque all 3/4" hardware to 250 ft-lbs.
5. Torque all 1/2" hardware to 75 ft-lbs.

PERIODICALLY CHECK THIS RECEIVER HITCH TO ENSURE THAT ALL FASTENERS ARE TIGHT AND THAT ALL STRUCTURAL COMPONENTS ARE SOUND.

Curt Manufacturing Inc., warrants this product to be free of defects in material and/or workmanship at the time of retail purchase by the original purchaser. If the product is found to be defective, Curt Manufacturing Inc., may repair or replace the product, at their option, when the product is returned, prepaid, with proof of purchase. Alteration to, misuse of, or improper installation of this product voids the warranty. Curt Manufacturing Inc.'s liability is limited to repair or replacement of products found to be defective, and specifically excludes liability for incidental or consequential loss or damage.