

13230**DODGE DAKOTA****6/13/2011**

**GROSS LOAD CAPACITY WHEN USED AS A WEIGHT CARRYING HITCH: 5,000 LBS. TRAILER WEIGHT & 500 LBS. TONGUE WEIGHT.
 GROSS LOAD CAPACITY WHEN USED AS A WEIGHT DISTRIBUTION HITCH: 8,000 LBS. TRAILER WEIGHT & 800 LBS. TONGUE WEIGHT**

*****DO NOT EXCEED VEHICLE MANUFACTURER'S RECOMMENDED TOWING CAPACITY.*****

Parts List			
ITEM	QTY	PART NUMBER	DESCRIPTION
1	1	3_4 - 10 x 3 FHSCS	FLAT HEAD SOCKET CAP SCREW, ZP
2	4	1/2"	WASHER WIDE

TOOLS REQUIRED
21mm SOCKET
1/2" HEX BIT SOCKET
RATCHET
TORQUE WRENCH

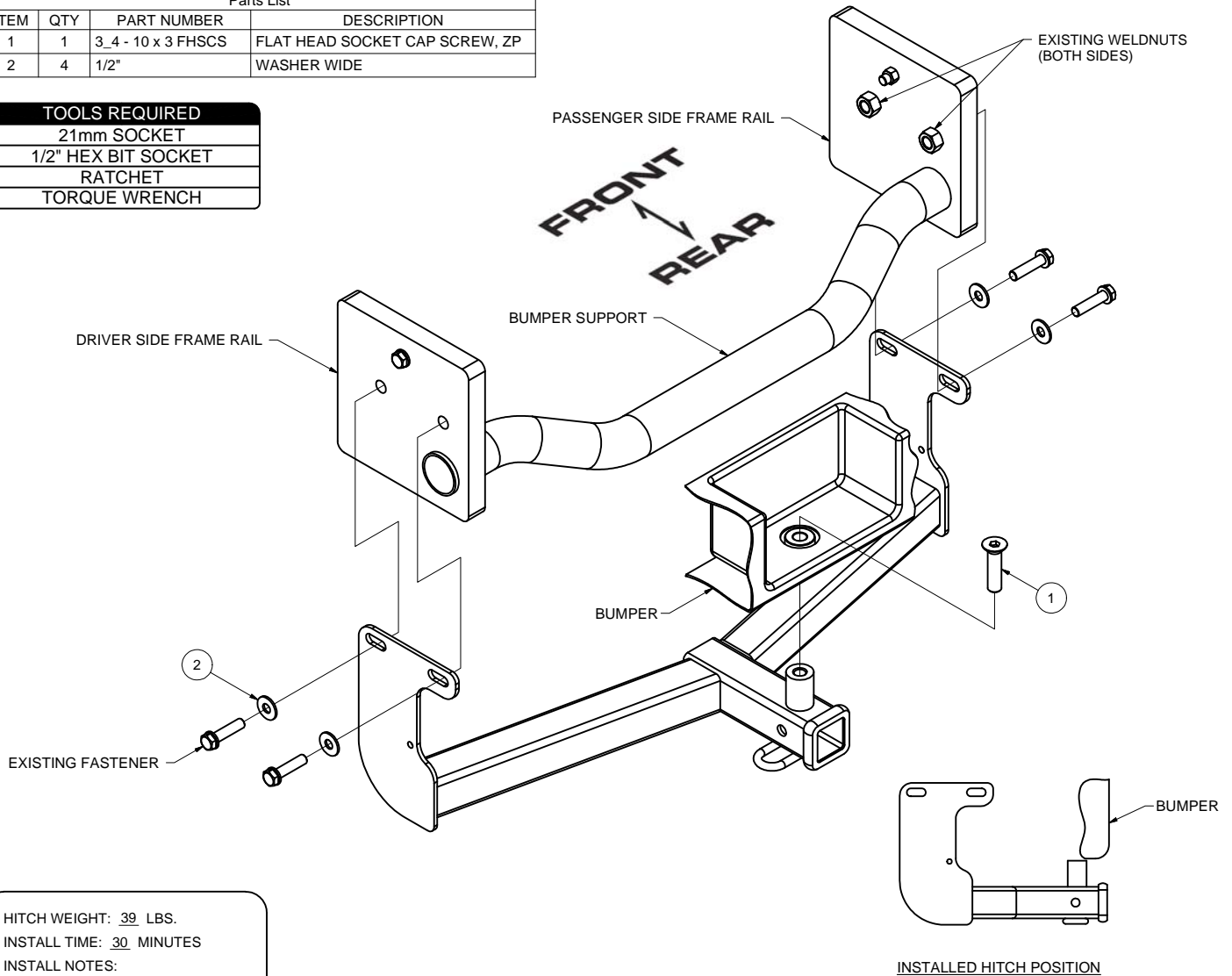

HITCH WEIGHT: 39 LBS.
 INSTALL TIME: 30 MINUTES
 INSTALL NOTES:
 - NO DRILLING REQUIRED

INSTALLATION STEPS

1. Remove the (4) existing M14 flange bolts from the frame, (2) per side, as shown. (Save the bolts for reuse in Step 2.)
2. Raise the hitch into position and reinstall the M14 flange bolts removed in Step 1 with the additional washers provided, as shown. Do not tighten.
3. Install the 3/4" flat head socket cap screw through the center hole in the bumper and into the threaded spacer on the hitch as shown.
4. Tighten the bolts installed in Step 2.
5. Torque all 3/4" fasteners to 250 ft-lbs, and all M14 fasteners to 94 ft-lbs.

PERIODICALLY CHECK THIS RECEIVER HITCH TO ENSURE THAT ALL FASTENERS ARE TIGHT AND THAT ALL STRUCTURAL COMPONENTS ARE SOUND.

Curt Manufacturing Inc., warrants this product to be free of defects in material and/or workmanship at the time of retail purchase by the original purchaser. If the product is found to be defective, Curt Manufacturing Inc., may repair or replace the product, at their option, when the product is returned, prepaid, with proof of purchase. Alteration to, misuse of, or improper installation of this product voids the warranty. Curt Manufacturing Inc.'s liability is limited to repair or replacement of products found to be defective, and specifically excludes liability for incidental or consequential loss or damage.