

13314

97-01 HONDA CRV

3/17/2011

GROSS LOAD CAPACITY WHEN USED AS A WEIGHT CARRYING HITCH: 3500 LBS. TRAILER WEIGHT & 350 LBS. TONGUE WEIGHT.

DO NOT EXCEED VEHICLE MANUFACTURER'S RECOMMENDED TOWING CAPACITY.

WARNING: ALL NON-TRAILER LOADS APPLIED TO THIS PRODUCT MUST BE SUPPORTED BY AUXILIARY STABILIZING STRAPS.

** FAILURE TO PROPERLY SUPPORT NON-TRAILER LOADS WILL VOID PRODUCT WARRANTY**

HAVING INSTALLATION QUESTIONS? CALL TECHNICAL SUPPORT AT 1-800-798-0813

Parts List			
ITEM	QTY	PART NUMBER	DESCRIPTION
1	4	7/16-14	HEX FLANGE NUT
2	4	CM-SP2	.250 x .88 x 2.25" SQUARE HOLE SPACER
3	2	7/16-14 x 1 1/4	CARRIAGE BOLT
4	2	7/16 - 14 x 1 3/4	CARRIAGE BOLT
5	1	CM-438-FW	7/16 " FISHWIRE TOOL
6	1	CM-3805-UBR	3/8-16 x 1.938 x .875" U-BOLT
7	2	HFN3816	HEX FLANGE NUT
31	2	ZSHIP 108	8" x 14" ADHESIVE WRAP (NOT SHOWN)

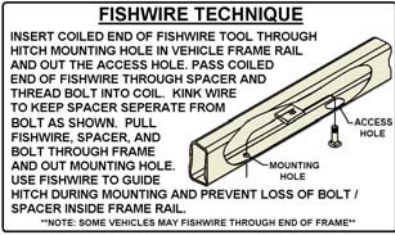
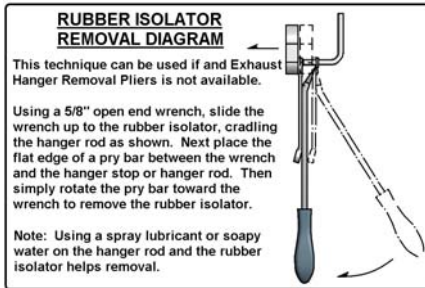
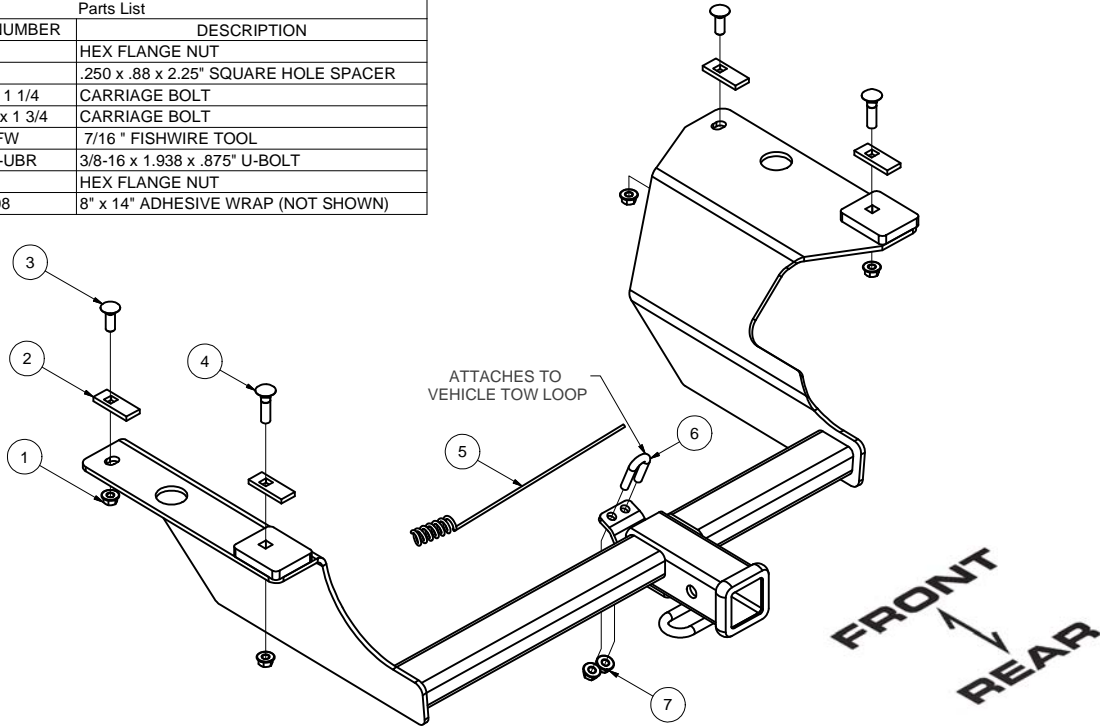

HITCH WEIGHT: 40 LBS.
 INSTALL TIME
 PROFESSIONAL: 45 MINUTES
 NOVICE (DIY): 90 MINUTES
 INSTALL NOTES:
 -DRILLING MAY BE REQUIRED

INSTALLATION STEPS

- 1) LOWER THE EXHAUST SYSTEM BY REMOVING THE TWO REAR EXHAUST HANGERS AND ONE IN FRONT OF THE AXLE.
- 2) AFTER THE EXHAUST HAS BEEN LOWERED FISHWIRE A 7/16" CARRIAGE BOLT AND SPACER THROUGH THE LARGE FRAME HOLE (Enlarge this hole to 1 1/4" if necessary) AND OUT THE SMALL FRONT HOLE IN THE FRAME.
- 3) REMOVE THE FISHWIRE FROM THE FRONT BOLT AND FISHWIRE A CARRIAGE BOLT AND SPACER INTO THE REAR FRAME HOLE. REMOVE THE FISHWIRE INSTALLATION TOOL AND REPEAT THE PROCESS FOR THE DRIVER SIDE FRAME RAIL.
- 4) AFTER ALL HARDWARE HAS BEEN PROPERLY INSTALLED RAISE THE HITCH INTO POSITION AND ATTACH THE 7/16" FLANGE NUTS PROVIDED. TORQUE THE 7/16" HARDWARE TO 50 FT/LBS.
- 5) WHEN THE HITCH IS PROPERLY INSTALLED RE-ATTACH THE THREE EXHAUST HANGERS WHICH WERE PREVIOUSLY REMOVED.

NOTE: MODIFY EXHAUST HANGERS AS NEEDED IF MUFFLER INTERFERES WITH HITCH

PERIODICALLY CHECK THIS RECEIVER HITCH TO ENSURE THAT ALL FASTENERS ARE TIGHT AND THAT ALL STRUCTURAL COMPONENTS ARE SOUND.

Curt Manufacturing Inc., warrants this product to be free of defects in material and/or workmanship at the time of retail purchase by the original purchaser. If the product is found to be defective, Curt Manufacturing Inc., may repair or replace the product, at their option, when the product is returned, prepaid, with proof of purchase. Alteration to, misuse of, or improper installation of this product voids the warranty. Curt Manufacturing Inc.'s liability is limited to repair or replacement of products found to be defective, and specifically excludes liability for incidental or consequential loss or damage.