

13318 / 757350**02-05 MERCEDES G500 (463 CHASSIS)****5/22/2008**

GROSS LOAD CAPACITY WHEN USED AS A WEIGHT CARRYING HITCH: 5,000 LBS. TRAILER WEIGHT & 500 LBS. TONGUE WEIGHT.
*****DO NOT EXCEED VEHICLE MANUFACTURER'S RECOMMENDED TOWING CAPACITY.*****

Parts List			
ITEM	QTY	PART NUMBER	DESCRIPTION
1	4	CM-SP108	2.00 X 0.88 X .125 SPACER
2	8	7/16 LOCK WASHER	HELICAL LOCK WASHER
3	4	7/16-14	HEX NUT
4	4	7/16-14 x 1 1/2	CARRIAGE BOLT
5	4	M10 - 1.5 x 40mm	HEX BOLT
6	4	3/8"	WASHER

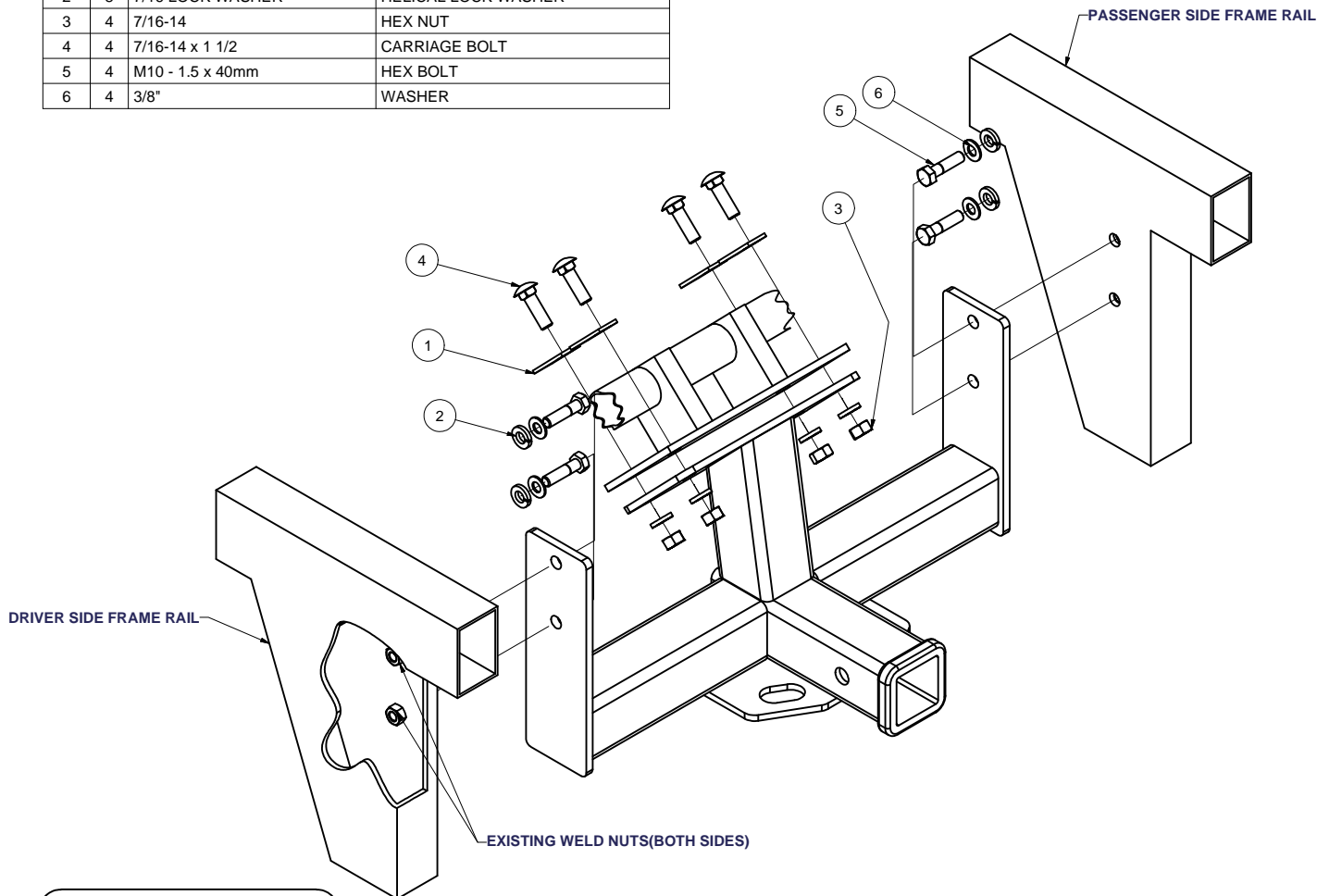

HITCH WEIGHT: 27 LBS.

INSTALL TIME: 20 MINUTES

INSTALL NOTES:

- NO DRILLING REQUIRED

INSTALLATION STEPS

1. Locate the tow loop extensions projecting from the driver and passenger side frame rails, and the angled plate on vehicle center as shown.
2. Use fasteners to mount the hitch as shown.
3. Room to wrench fasteners is limited. Wrenching may be easier from the rear of vehicle.
4. Torque 10mm fasteners to 38 lb-ft.
Torque 7/16" carriage bolts to 50 lb-ft.

PERIODICALLY CHECK THIS RECEIVER HITCH TO ENSURE THAT ALL FASTENERS ARE TIGHT AND THAT ALL STRUCTURAL COMPONENTS ARE SOUND.

Curt Manufacturing Inc., warrants this product to be free of defects in material and/or workmanship at the time of retail purchase by the original purchaser. If the product is found to be defective, Curt Manufacturing Inc., may repair or replace the product, at their option, when the product is returned, prepaid, with proof of purchase. Alteration to, misuse of, or improper installation of this product voids the warranty. Curt Manufacturing Inc.'s liability is limited to repair or replacement of products found to be defective, and specifically excludes liability for incidental or consequential loss or damage.