

13354

ACURA MDX

11/11/11

GROSS LOAD CAPACITY WHEN USED AS A WEIGHT CARRYING HITCH: 4,000 LBS. TRAILER WEIGHT & 400 LBS. TONGUE WEIGHT.
GROSS LOAD CAPACITY WHEN USED AS A WEIGHT DISTRIBUTION HITCH: 5,000 LBS. TRAILER WEIGHT & 500 LBS. TONGUE WEIGHT

DO NOT EXCEED VEHICLE MANUFACTURER'S RECOMMENDED TOWING CAPACITY.

Parts List			
ITEM	QTY	PART NUMBER	DESCRIPTION
1	4	M14 - 1.5 x 35 HEX	HEX BOLT
2	4	9/16" CONICAL WASHER	CONICAL TOOTHED WASHER
3	4	M14 - 1.5 x 40 HEX	HEX FLANGE BOLT

TOOLS REQUIRED	
3/8" DRIVE RATCHET	
22mm - 3/8" DRIVE SOCKET	
10mm - 3/8" DRIVE SOCKET	
TORQUE WRENCH	

PASSENGER SIDE
FRAME RAIL

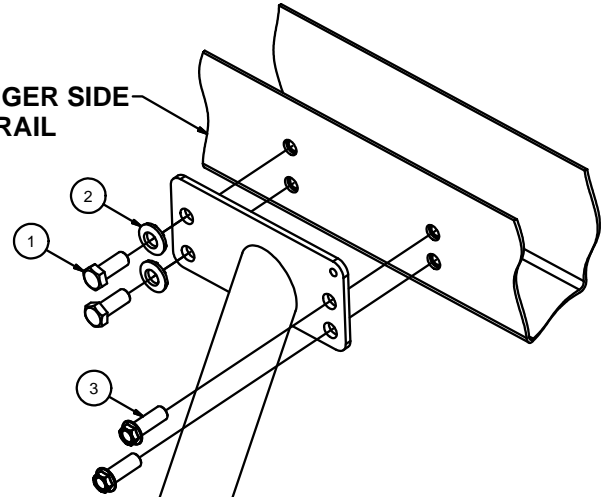

FRONT
↓
REAR

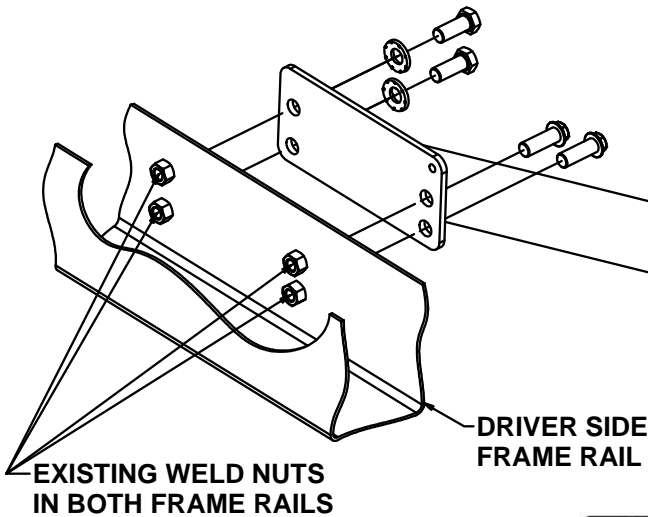

DRIVER SIDE
FRAME RAIL

CONICAL TOOTHED WASHER
ORIENTATION DIAGRAM

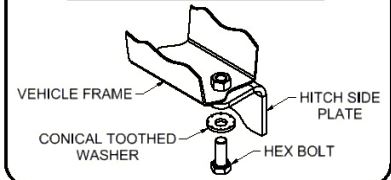

HITCH WEIGHT: 28 LBS.

INSTALL TIME: 30 MINUTES

INSTALL NOTES:

- NO DRILLING REQUIRED
- LOWER SPARE TIRE AND EXHAUST
- REMOVE / RE-INSTALL HEAT SHIELD

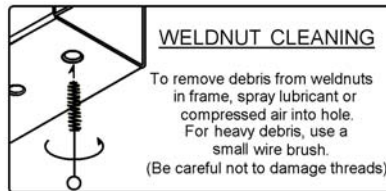

INSTALLATION STEPS

- 1) Remove the muffler hanger to allow the exhaust to drop down. Remove spare tire and muffler heat shield to ease installation.
Note: Retain heat shields and hardware for re-installation.
- 2) Raise hitch into position between frame rails and install fasteners as shown above.
- 3) Torque all 14mm fasteners to 101 lb-ft.
- 4) Re-install heat shield and spare tire (if removed), and re-attach muffler hangers.

PERIODICALLY CHECK THIS RECEIVER HITCH TO ENSURE THAT ALL FASTENERS ARE TIGHT AND THAT ALL STRUCTURAL COMPONENTS ARE SOUND.

Curt Manufacturing Inc., warrants this product to be free of defects in material and/or workmanship at the time of retail purchase by the original purchaser. If the product is found to be defective, Curt Manufacturing Inc., may repair or replace the product, at their option, when the product is returned, prepaid, with proof of purchase. Alteration to, misuse of, or improper installation of this product voids the warranty. Curt Manufacturing Inc.'s liability is limited to repair or replacement of products found to be defective, and specifically excludes liability for incidental or consequential loss or damage.