



13356 INSTALLATION INSTRUCTIONS

! Safety glasses should be worn at all times while installing this product.

YEARS: 2009-CURRENT

MAKE: TOYOTA

MODEL: VENZA

STYLE: CROSSOVER

WARNING: NEVER EXCEED YOUR VEHICLE MANUFACTURER'S RECOMMENDED TOWING CAPACITY

WEIGHT CARRYING:
TRAILER WEIGHT: 3,500 LBS.
TONGUE WEIGHT: 350 LBS.

WEIGHT DISTRIBUTION:
TRAILER WEIGHT: 4,000 LBS.
TONGUE WEIGHT: 400 LBS.







INSTALLATION TIME: 30 MIN.

THE INSTALL TIME LISTED IS FOR PROFESSIONAL INSTALLERS. IF YOU ARE HESITANT TO UNDERTAKE THIS TASK ON YOUR OWN, CONTACT AN AUTHORIZED CURT INSTALLER FOR ADDITIONAL ASSISTANCE.

INSTALLATION TIPS:

- BEFORE YOU BEGIN INSTALLATION, READ ALL INSTRUCTIONS THOROUGHLY.
- TO EASE INSTALLATION, 2 PEOPLE MAY BE REQUIRED.
- USING PROPER TOOLS WILL GREATLY IMPROVE THE QUALITY OF THE INSTALL AND REDUCE THE TIME REQUIRED.
- NEED HELP OR HAVE SOME QUESTIONS? CALL TECHNICAL SUPPORT AT 800.798.0813

INSTALLATION REQUIRES:

 RATCHET	 TORQUE WRENCH	 12" SOCKET EXTENSION
 SWIVEL SOCKET EXTENSION	 12mm 14mm 17mm SOCKET	 14mm DEEP WELL SOCKET
 SAFETY GLASSES		

LEVEL OF DIFFICULTY: EASY

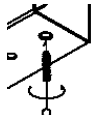
EASY	MODERATE	CHALLENGING
		
	NO DRILL	
		
	WELD NUT CLEANING	

VEHICLE PHOTO:



REPRESENTATIVE PHOTO

HITCH ILLUSTRATION:

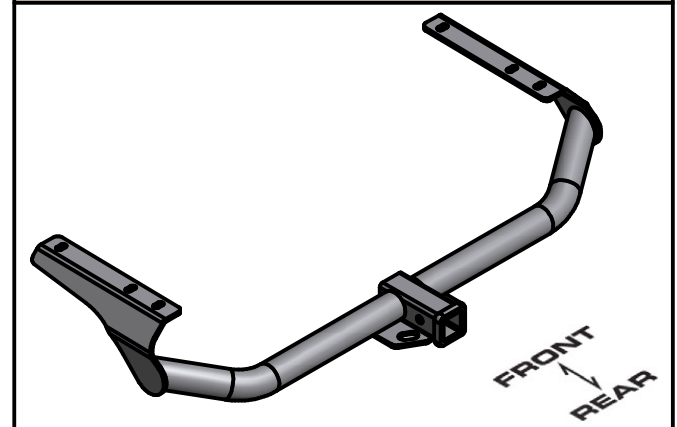

MAKE SURE YOUR HITCH MATCHES

PERIODICALLY CHECK THIS RECEIVER HITCH TO ENSURE ALL FASTENERS ARE TIGHT AND ALL STRUCTURAL COMPONENTS ARE SOUND

CURT Manufacturing LLC. warrants this product to be free of defects in material and/or workmanship at the time of retail purchase by the original purchaser. If the product is found to be defective, Curt Manufacturing LLC. may repair or replace the product at their option, when the product is returned, prepaid, with proof of purchase. Alteration to, misuse of, or improper installation of this product voids the warranty. Curt Manufacturing LLC.'s liability is limited to repair or replacement of products found to be defective, and specifically excludes liability for incidental or consequential loss or damage.

For more information log onto www.curtmfg.com, & for helpful towing tips log onto www.hitchinfo.com

INSTALLATION WALKTHROUGH:

Parts List			
ITEM	QTY	PART NUMBER	DESCRIPTION
1	6	M10 - 1.25 x 40 HEX	HEX BOLT
2	6	3/8"	CONICAL TOOTHED WASHER
3	2	CM-SP50	.250 x 1.00 x 1.50" ROUND HOLE SPACER

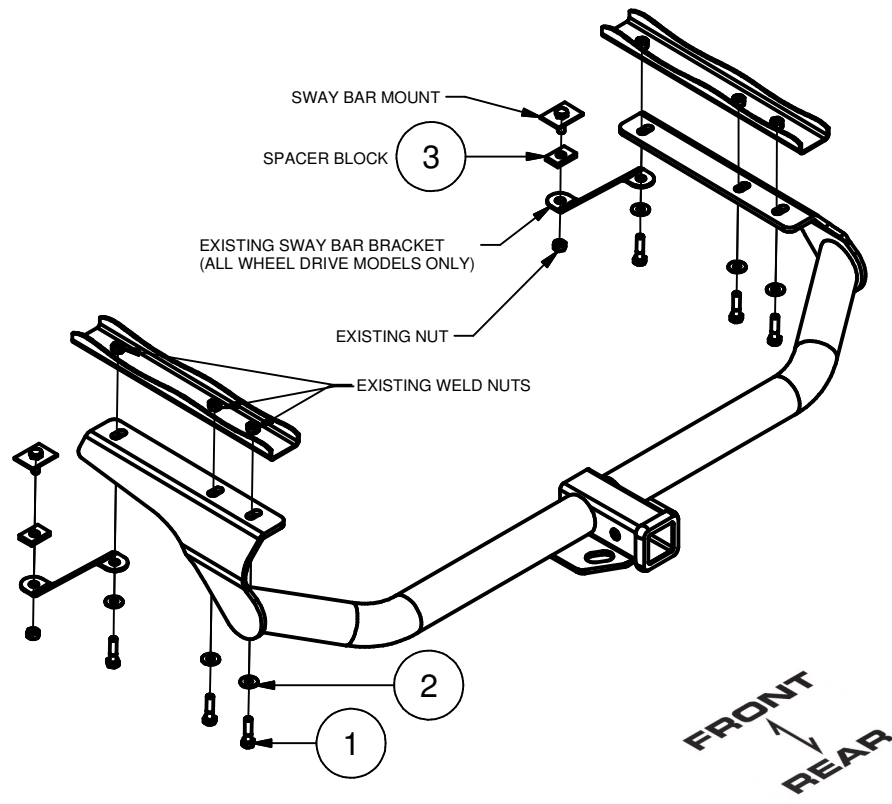

1) If the vehicle is all wheel drive, remove the (2) sway bar brackets. Save the existing nuts for use in step 4.



2) Remove the stickers covering the (4) weld nuts in the frame rail.

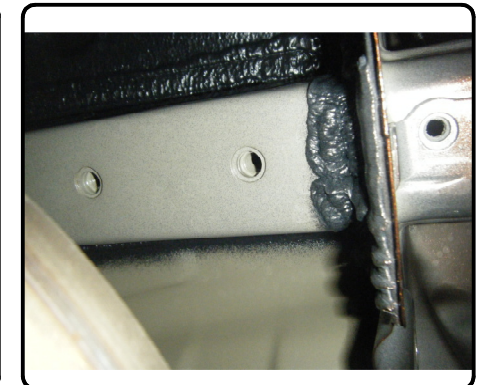

INSTALLATION WALKTHROUGH:

3) Lower the exhaust by removing the (4) hex flange bolts securing the isolator hanger brackets to the frame. Save the bolts for use in step 6.



4) Raise the hitch into position and install (3) 10mm bolts and conical toothed washers per side into the existing weldnuts in the frame. If the vehicle is all wheel drive then reinstall the sway bar brackets using CM-SP50 spacer blocks and the existing nuts on the lower mounts.



5) Torque all M10 hardware to 37 ft-lbs.



6) Raise exhaust into position and secure isolator mounts using the bolts removed in step 3. Install is now complete.

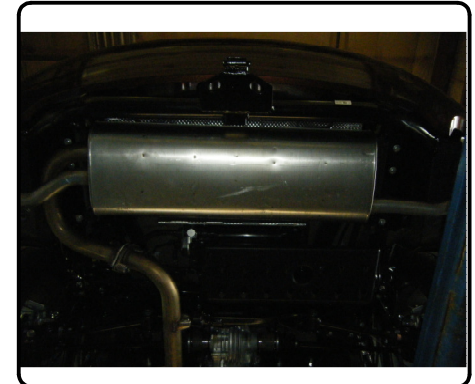

13356**TOYOTA VENZA****1/30/2009**

GROSS LOAD CAPACITY WHEN USED AS A WEIGHT CARRYING HITCH: 3,500 LBS. TRAILER WEIGHT & 350 LBS. TONGUE WEIGHT.
 GROSS LOAD CAPACITY WHEN USED AS A WEIGHT DISTRIBUTION HITCH: 4,000 LBS. TRAILER WEIGHT & 400 LBS. TONGUE WEIGHT
*****DO NOT EXCEED VEHICLE MANUFACTURER'S RECOMMENDED TOWING CAPACITY.*****
 HAVING INSTALLATION QUESTIONS? CALL TECHNICAL SUPPORT AT 1-800-798-0813

Parts List			
ITEM	QTY	PART NUMBER	DESCRIPTION
1	6	M10 - 1.25 x 40 HEX	HEX BOLT
2	6	3/8"	CONICAL TOOTHED WASHER
3	2	CM-SP50	.250 x 1.00 x 1.50" SPACER

TOOLS REQUIRED

12, 14 AND 17 mm SOCKETS
 14mm DEEP SOCKET
 SWIVEL EXTENSION
 12" EXTENSION
 RATCHET
 TORQUE WRENCH

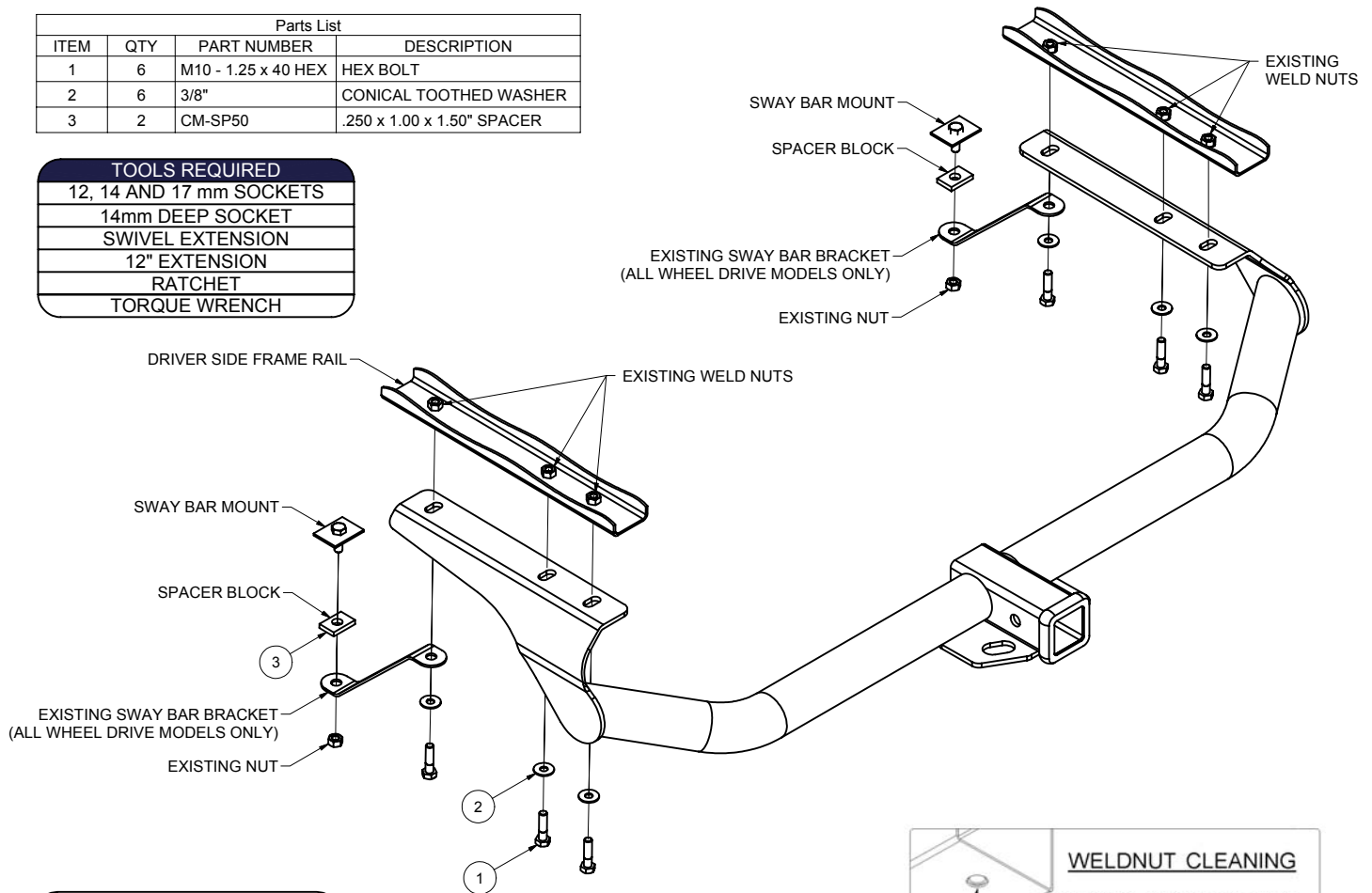
**WELDNUT CLEANING**

To remove debris from weldnuts in frame, spray lubricant or compressed air into hole. For heavy debris, use a small wire brush. (Be careful not to damage threads).

HITCH WEIGHT: 35 LBS.
 INSTALL TIME: 30 MINUTES
 INSTALL NOTES:
 - NO DRILLING REQUIRED
 - LOWER EXHAUST

INSTALLATION STEPS

1. If the vehicle is all wheel drive, remove the (2) sway bar brackets. Save the existing nuts for use in Step 4.
2. Remove the stickers covering the (4) weld nuts in the frame rail.
3. Lower the exhaust by removing the (4) hex flange bolts securing the isolator hanger brackets to the frame. Save the bolts for use in Step 6.
4. Raise the hitch into position and install (3) 10mm bolts and conical toothed washers per side into the existing weldnuts in the vehicle frame as shown. If the vehicle is all wheel drive then reinstall the sway bar brackets using CM-SP50 spacers and the existing nuts on the lower mounts as shown.
5. Torque all M10 hardware to 37 ft-lbs.
6. Raise exhaust into position and secure isolator mounts using the bolts removed in Step 3.

PERIODICALLY CHECK THIS RECEIVER HITCH TO ENSURE THAT ALL FASTENERS ARE TIGHT AND THAT ALL STRUCTURAL COMPONENTS ARE SOUND.

Curt Manufacturing Inc., warrants this product to be free of defects in material and/or workmanship at the time of retail purchase by the original purchaser. If the product is found to be defective, Curt Manufacturing Inc., may repair or replace the product, at their option, when the product is returned, prepaid, with proof of purchase. Alteration to, misuse of, or improper installation of this product voids the warranty. Curt Manufacturing Inc.'s liability is limited to repair or replacement of products found to be defective, and specifically excludes liability for incidental or consequential loss or damage.