

13374

DODGE RAM 1500 WITHOUT OEM HITCH

2/16/2012

PAGE 1 OF 2

GROSS LOAD CAPACITY WHEN USED AS A WEIGHT CARRYING HITCH: 6,000 LBS. TRAILER WEIGHT & 600 LBS. TONGUE WEIGHT.
GROSS LOAD CAPACITY WHEN USED AS A WEIGHT DISTRIBUTION HITCH: 10,000 LBS. TRAILER WEIGHT & 1,000 LBS. TONGUE WEIGHT

***** DO NOT EXCEED VEHICLE MANUFACTURER'S RECOMMENDED TOWING CAPACITY. *****

HAVING INSTALLATION QUESTIONS? CALL TECHNICAL SUPPORT AT 1-800-798-0813

Parts List				
ITEM	QTY	PART NUMBER	DESCRIPTION	
1	2	CM-SP4	.250 x 1.50 x 3.00" SQUARE HOLE SPACER	
2	2	CM-SP40	.188 x 1.00 x 3.00" SQUARE HOLE SPACER	
3	4	HFN 1213	HEX FLANGE NUT	
4	4	1/2-13 x 1 1/2	CARRIAGE BOLT	
5	2	1_2 x 30 FISHWIRE	1/2" x 30" FISHWIRE	

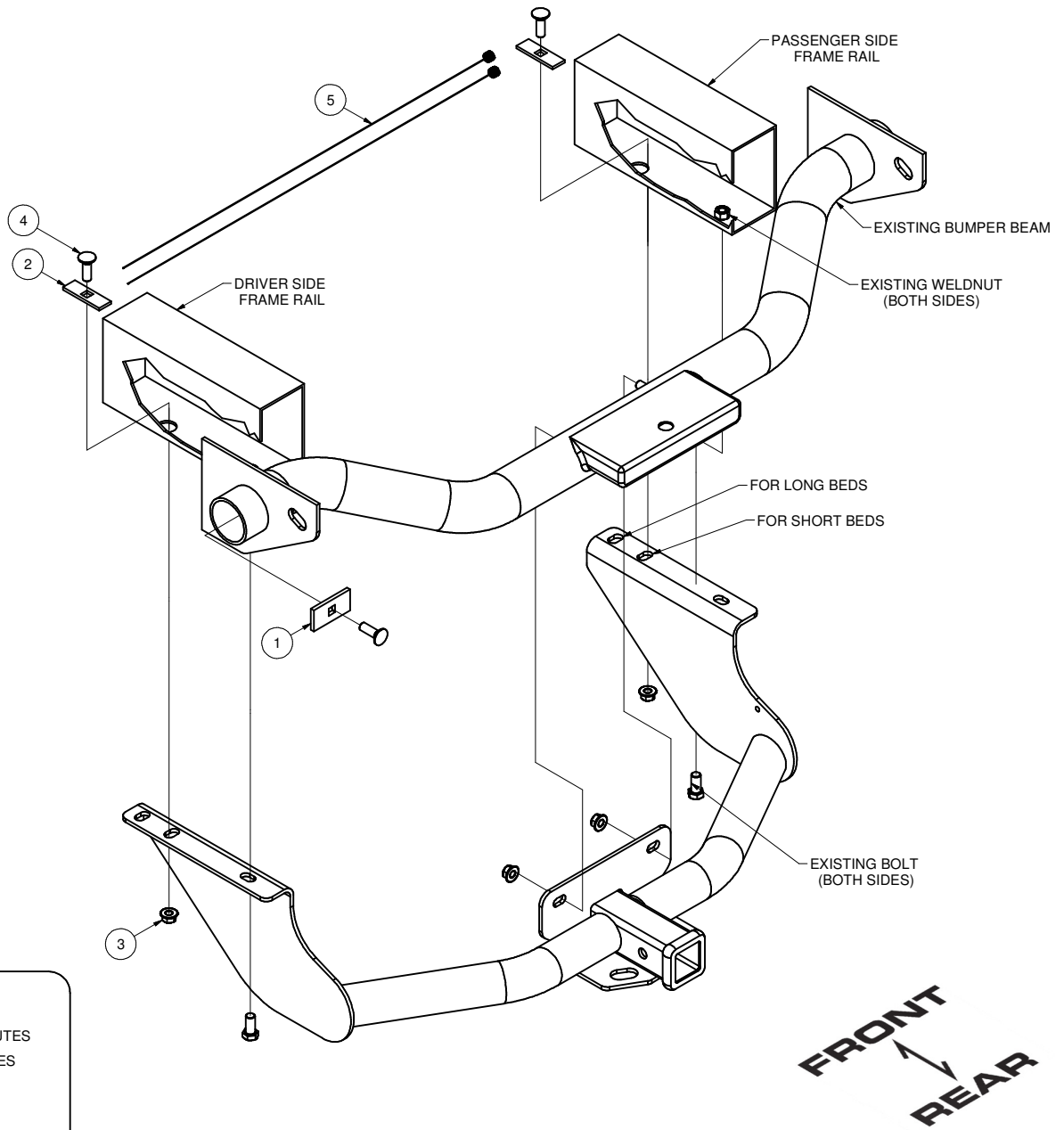

HITCH WEIGHT: 43 LBS.

INSTALL TIME

PROFESSIONAL: 30 MINUTES

NOVICE (DIY): 60 MINUTES

INSTALL NOTES:

- NO DRILLING REQUIRED
- FISHWIRE HARDWARE
- LOWER SPARE TIRE
- REMOVE EXISTING BOLTS

PERIODICALLY CHECK THIS RECEIVER HITCH TO ENSURE THAT ALL FASTENERS ARE TIGHT AND THAT ALL STRUCTURAL COMPONENTS ARE SOUND.

Curt Manufacturing Inc., warrants this product to be free of defects in material and/or workmanship at the time of retail purchase by the original purchaser. If the product is found to be defective, Curt Manufacturing Inc., may repair or replace the product, at their option, when the product is returned, prepaid, with proof of purchase. Alteration to, misuse of, or improper installation of this product voids the warranty. Curt Manufacturing Inc.'s liability is limited to repair or replacement of products found to be defective, and specifically excludes liability for incidental or consequential loss or damage.

GROSS LOAD CAPACITY WHEN USED AS A WEIGHT CARRYING HITCH: 6,000 LBS. TRAILER WEIGHT & 600 LBS. TONGUE WEIGHT.
GROSS LOAD CAPACITY WHEN USED AS A WEIGHT DISTRIBUTION HITCH: 10,000 LBS. TRAILER WEIGHT & 1,000 LBS. TONGUE WEIGHT

***** DO NOT EXCEED VEHICLE MANUFACTURER'S RECOMMENDED TOWING CAPACITY. *****

HAVING INSTALLATION QUESTIONS? CALL TECHNICAL SUPPORT AT 1-800-798-0813

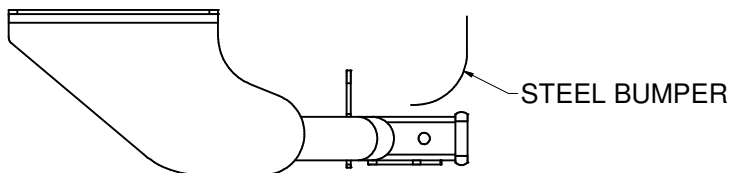
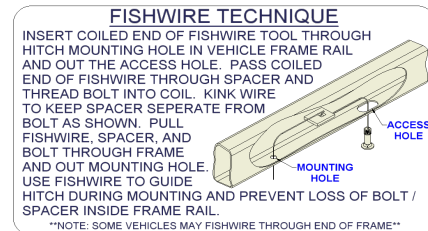
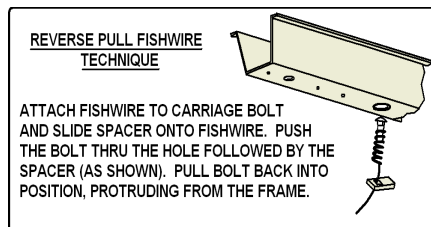
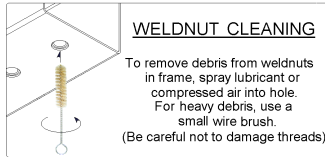

INSTALLED HITCH POSITION

TOOLS REQUIRED
SOCKET WRENCH
TORQUE WRENCH
6" SOCKET EXTENSION
3/4" SOCKET
21mm SOCKET

INSTALLATION STEPS

1. Lower spare tire for ease of installation.
2. Remove existing M14 bolts connecting bumper beam to frame rail on driver and passenger side of vehicle. Save bolts for use in Step 6.
3. Reverse fishwire 1/2-13 x 1 1/2" carriage bolts and CM-SP40 spacers through large round holes in driver and passenger side frame rails of vehicle. (See REVERSE PULL FISHWIRE TECHNIQUE.)
4. Fishwire 1/2-13 x 1 1/2" carriage bolts and CM-SP4 spacers through ends of bumper beam and out slot in front of bumper beam, as shown. (See FISHWIRE TECHNIQUE diagram.)
5. Raise hitch into position and loosely install 1/2-13 hex flange nuts on to 1/2" carriage bolts, as shown.
6. Reinstall bolts removed in Step 2.
7. Torque 1/2" hardware to 75 lb-ft and M14 hardware to 100 lb-ft.
8. Raise spare tire back into position.

PERIODICALLY CHECK THIS RECEIVER HITCH TO ENSURE THAT ALL FASTENERS ARE TIGHT AND THAT ALL STRUCTURAL COMPONENTS ARE SOUND.

Curt Manufacturing Inc., warrants this product to be free of defects in material and/or workmanship at the time of retail purchase by the original purchaser. If the product is found to be defective, Curt Manufacturing Inc., may repair or replace the product, at their option, when the product is returned, prepaid, with proof of purchase. Alteration to, misuse of, or improper installation of this product voids the warranty. Curt Manufacturing Inc.'s liability is limited to repair or replacement of products found to be defective, and specifically excludes liability for incidental or consequential loss or damage.