

13375

DODGE SPRINTER 3500 CARGO VAN w/FACTORY STEP BUMPER 144" WHEEL BASE

6/08/2009

GROSS LOAD CAPACITY WHEN USED AS A WEIGHT CARRYING HITCH: 5,000 LBS. TRAILER WEIGHT & 500 LBS. TONGUE WEIGHT.
GROSS LOAD CAPACITY WHEN USED AS A WEIGHT DISTRIBUTION HITCH: 7,500 LBS. TRAILER WEIGHT & 750 LBS. TONGUE WEIGHT

*****DO NOT EXCEED VEHICLE MANUFACTURER'S RECOMMENDED TOWING CAPACITY.*****

HAVING INSTALLATION QUESTIONS? CALL TECHNICAL SUPPORT AT 1-800-798-0813

Parts List				
ITEM	QTY	PART NUMBER	DESCRIPTION	
1	4	CM-13375-SP	SPACER PLATE .500" A-36 H.R.	
2	8	HFN 1213	HEX FLANGE NUT	
3	2	CM-SP25	.250 x 1.38 x 1.50" ROUND HOLE SPACER	
4	8	FW12	FW, 12, ZP	
5	8	1_2 - 13 x 5 HEX	HEX BOLT	

TOOLS REQUIRED
TORQUE WRENCH
RATCHET
18mm SOCKET
18mm WRENCH
3/4" SOCKET
3/4" WRENCH

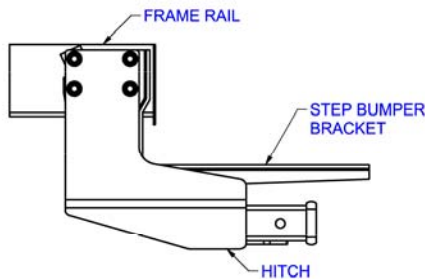

HITCH SHOWN IN PROPER POSITION

HITCH WEIGHT: 41 LBS.

INSTALL TIME

PROFESSIONAL: 30 MINUTES

NOVICE (DIY): 60 MINUTES

INSTALL NOTES:

- NO DRILLING REQUIRED
- LOWER SPARE TIRE

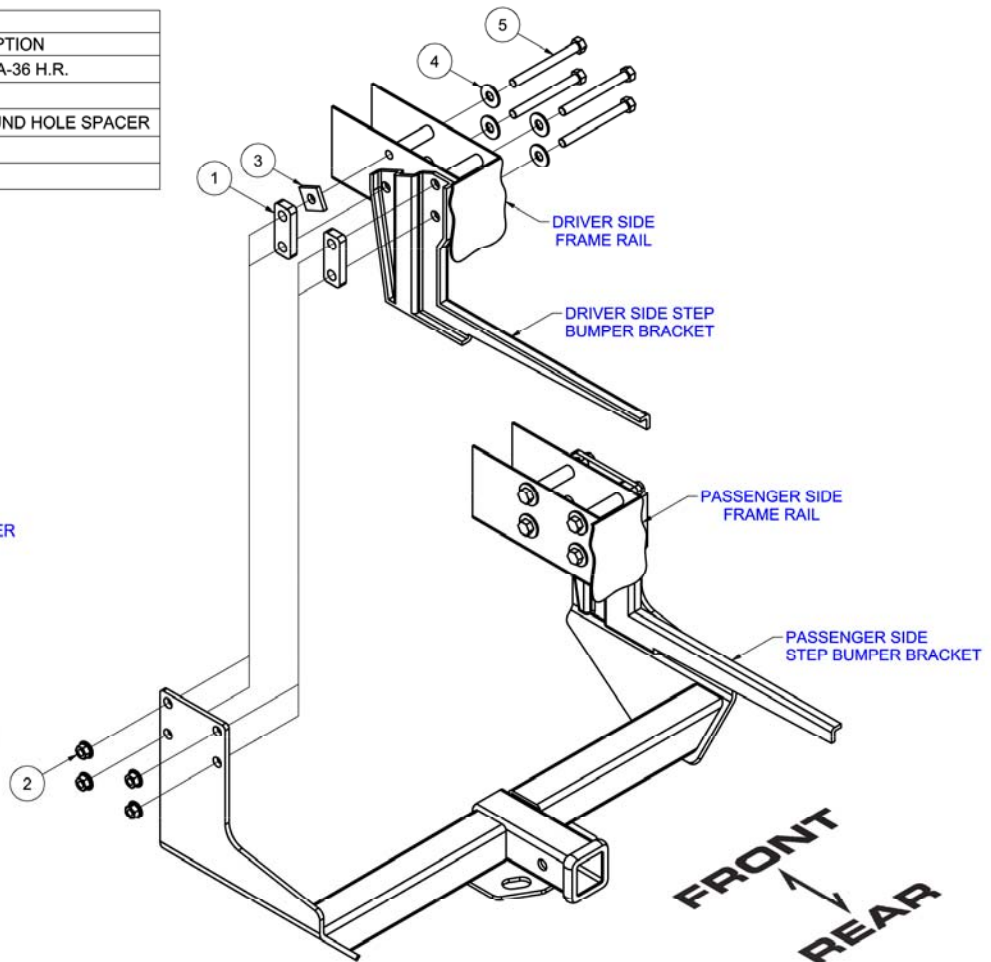

INSTALLATION STEPS

1. Lower spare tire for ease of installation.
2. Remove (6) existing bolts and nuts from bumper mounting brackets and return to owner.
NOTE: Support bumper as necessary to prevent from falling.
3. Install 1/2" X 5" hex head bolts and 1/2" flat washers from the inside of the frame rail through existing holes and out step bumper bracket holes as shown.
4. Install SP25 spacer over the upper forward most bolt, each side. Install (2) 1/2" spacer plates over the bolts on each side of vehicle as shown.
NOTE: For ease of installation push hex bolts back so the threaded portion is flush with the 1/2" spacer plates.
5. Raise hitch into position by sliding the hitch side plates over the outside of the bumper mounting brackets and aligning the holes as shown. Push the remainder of each bolt through the holes in the hitch side plates.
6. Secure hitch into position using 1/2" hex flange nut.
7. Torque all 1/2" hardware to 75 ft-lbs.
8. Reinstall spare tire.

PERIODICALLY CHECK THIS RECEIVER HITCH TO ENSURE THAT ALL FASTENERS ARE TIGHT AND THAT ALL STRUCTURAL COMPONENTS ARE SOUND.

Curt Manufacturing Inc., warrants this product to be free of defects in material and/or workmanship at the time of retail purchase by the original purchaser. If the product is found to be defective, Curt Manufacturing Inc., may repair or replace the product, at their option, when the product is returned, prepaid, with proof of purchase. Alteration to, misuse of, or improper installation of this product voids the warranty. Curt Manufacturing Inc.'s liability is limited to repair or replacement of products found to be defective, and specifically excludes liability for incidental or consequential loss or damage.