

13388

# DODGE / MERCEDES / FREIGHTLINER SPRINTER 2500 & 3500 (ALL WITH STANDARD BUMPER)

5/1/2018

GROSS LOAD CAPACITY WHEN USED AS A WEIGHT CARRYING HITCH: 6,000 LBS. TRAILER WEIGHT & 600 LBS. TONGUE WEIGHT.  
GROSS LOAD CAPACITY WHEN USED AS A WEIGHT DISTRIBUTION HITCH: 10,000 LBS. TRAILER WEIGHT & 1,000 LBS. TONGUE WEIGHT



**WARNING: \*\*\* DO NOT EXCEED VEHICLE MANUFACTURER'S RECOMMENDED TOWING CAPACITY. \*\*\***

FOR MORE INFORMATION LOG ONTO [WWW.CURTMFG.COM](http://WWW.CURTMFG.COM)  
HAVING INSTALLATION QUESTIONS? CALL TECHNICAL SUPPORT AT 1-800-798-0813



Parts List			
ITEM	QTY	PART NUMBER	DESCRIPTION
1	6	7_16 - 14 x 4 1_2 HEX	HEX BOLT
2	6	7/16 WASHER	WASHER
3	6	7/16-14	HEX FLANGE NUT
4	1	CM-500-FW	FISHWIRE TOOL
5	2	CM-SP6	.250 x 1.00 x 3.00" SQUARE HOLE SPACER
6	2	1/2-13 x 1 1/2	CARRIAGE BOLT
7	2	HFN 1213	HEX FLANGE NUT

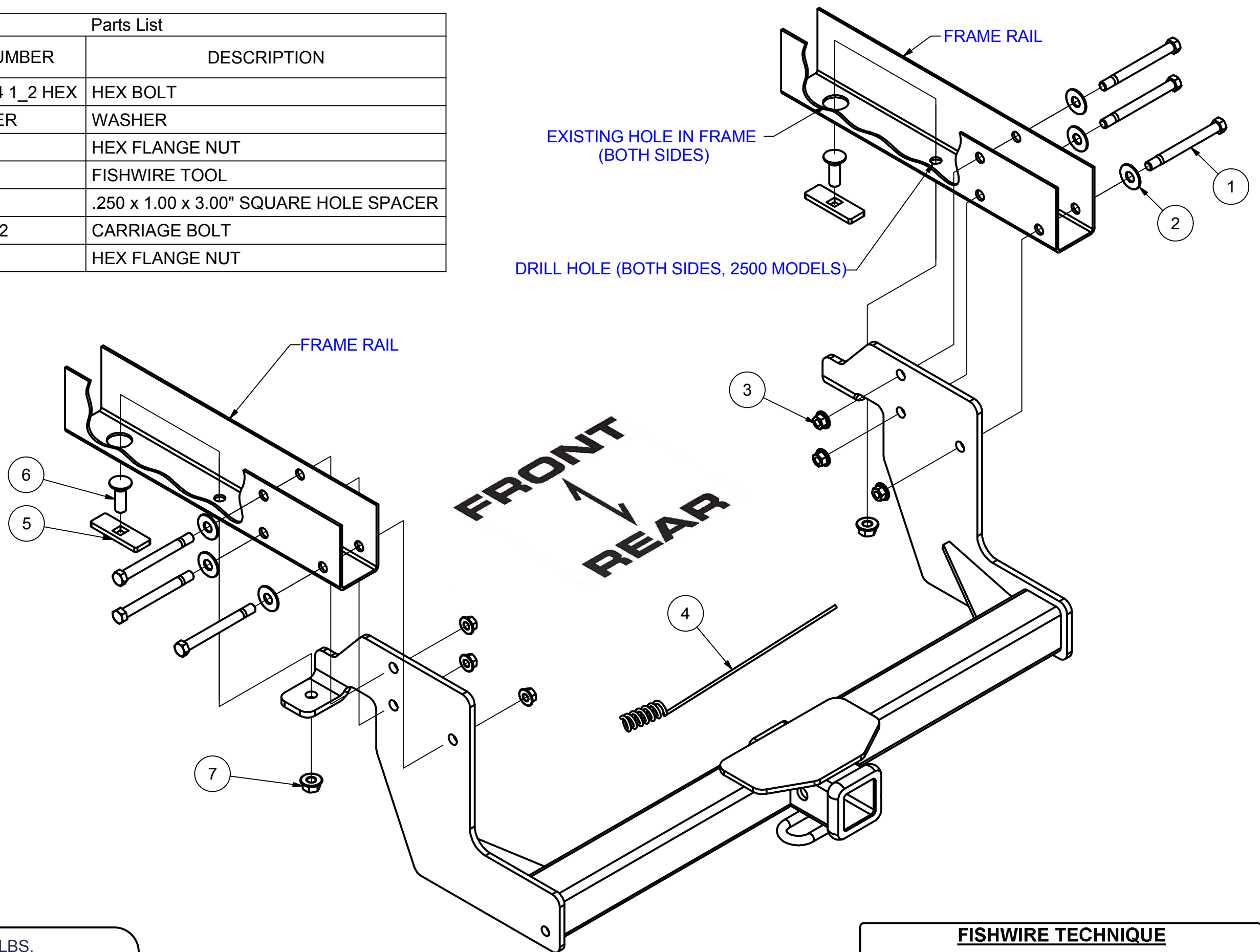

HITCH WEIGHT: 45 LBS.

#### INSTALL TIME

PROFESSIONAL: 30 MINUTES

NOVICE (DIY): 60 MINUTES

#### INSTALL NOTES:

- DRILLING MAY BE REQUIRED
- FISHWIRE HARDWARE

#### REVERSE PULL FISHWIRE TECHNIQUE

ATTACH FISHWIRE TO CARRIAGE BOLT AND SLIDE SPACER ONTO FISHWIRE. PUSH THE BOLT THRU THE HOLE FOLLOWED BY THE SPACER (AS SHOWN). PULL BOLT BACK INTO POSITION, PROTRUDING FROM THE FRAME.

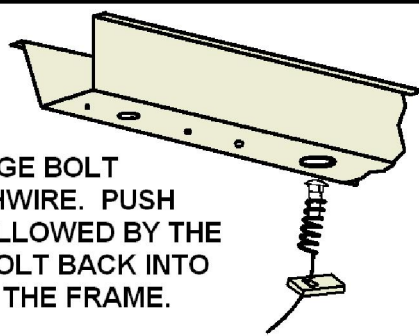

#### FISHWIRE TECHNIQUE

INSERT COILED END OF FISHWIRE TOOL THROUGH HITCH MOUNTING HOLE IN VEHICLE FRAME RAIL AND OUT THE ACCESS HOLE. PASS COILED END OF FISHWIRE THROUGH SPACER AND THREAD BOLT INTO COIL. KINK WIRE TO KEEP SPACER SEPARATE FROM BOLT AS SHOWN. PULL FISHWIRE, SPACER, AND BOLT THROUGH FRAME AND OUT MOUNTING HOLE. USE FISHWIRE TO GUIDE HITCH DURING MOUNTING AND PREVENT LOSS OF BOLT / SPACER INSIDE FRAME RAIL.

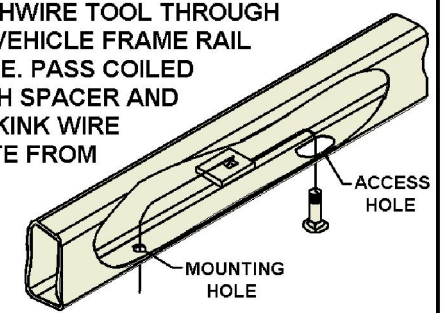

\*NOTE: SOME VEHICLES MAY FISHWIRE THROUGH END OF FRAME\*

## INSTALLATION STEPS

1. Remove bolts and brackets (1 bolt per bracket) or remove tow loop (3 bolts per loop) if equipped.
2. Raise hitch into position, aligning holes. Passenger side must be raised into position first to allow for the extra space needed to fit around exhaust.
- 3a. For 3500 models, secure hitch to frame using 7/16" hardware supplied.
- 3b. For 2500 models, secure hitch to frame using 7/16" hardware supplied. Using hitch as template, drill holes into bottom of frame.
4. Fishwire CM-SP6 spacers and 1/2" carriage bolts through access hole and out drilled hole.
5. Torque all 7/16" hardware to 70 lb-ft. and all 1/2" hardware to 110 lb-ft.



Scan for more information

**PERIODICALLY CHECK THIS RECEIVER HITCH TO ENSURE THAT ALL FASTENERS ARE TIGHT AND THAT ALL STRUCTURAL COMPONENTS ARE SOUND.**

CURT Manufacturing LLC., warrants this product to be free of defects in material and/or workmanship at the time of retail purchase by the original purchaser. If the product is found to be defective, CURT Manufacturing LLC., may repair or replace the product, at their option, when the product is returned, prepaid, with proof of purchase. Alteration to, misuse of, or improper installation of this product voids the warranty. CURT Manufacturing LLC.'s liability is limited to repair or replacement of products found to be defective, and specifically excludes liability for incidental or consequential loss or damage.

This product complies with safety specifications and requirements for connecting devices and towing systems of the state of New York, V.E.S.C.Regulation V-5 and SAE J684.