

13408**97-06 JEEP WRANGLER**

2/17/2012

GROSS LOAD CAPACITY WHEN USED AS A WEIGHT CARRYING HITCH: 4,000 LBS. TRAILER WEIGHT & 400 LBS. TONGUE WEIGHT.

DO NOT EXCEED VEHICLE MANUFACTURER'S RECOMMENDED TOWING CAPACITY.

WARNING: ALL NON-TRAILER LOADS APPLIED TO THIS PRODUCT MUST BE SUPPORTED BY 18050 STABILIZING STRAPS.

** FAILURE TO PROPERLY SUPPORT NON-TRAILER LOADS WILL VOID PRODUCT WARRANTY**

HAVING INSTALLATION QUESTIONS? CALL TECHNICAL SUPPORT AT 1-800-798-0813

Parts List			
ITEM	QTY	PART NUMBER	DESCRIPTION
1	1	1/2"	FISHWIRE TOOL
2	2	HFN 1213	HEX FLANGE NUT
3	2	7/16-14 x 1 3/4	HEX BOLT
4	2	M12 - 1.75 x 50mm	HEX BOLT
5	2	CM-SP10	.250 x 1.00 x 2.50" SQUARE HOLE SPACER
6	2	1/2"	CONICAL TOOTHED WASHER
7	2	1/2-13 x 1 3/4	CARRIAGE BOLT

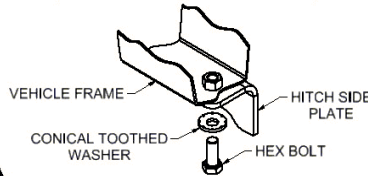
**CONICAL TOOTHED WASHER
ORIENTATION DIAGRAM****TOOLS REQUIRED**

RATCHET
TORQUE WRENCH
9" EXTENSION
18mm SOCKET
19mm SOCKET
5/8" SOCKET
3/4" SOCKET

FISHWIRE TECHNIQUE

INSERT COILED END OF FISHWIRE TOOL THROUGH HITCH MOUNTING HOLE IN VEHICLE FRAME RAIL AND OUT THE ACCESS HOLE. PASS COILED END OF FISHWIRE THROUGH SPACER AND THREAD BOLT INTO COIL. KINK WIRE TO KEEP SPACER SEPERATE FROM BOLT AS SHOWN. PULL FISHWIRE, SPACER, AND BOLT THROUGH FRAME AND OUT MOUNTING HOLE. USE FISHWIRE TO GUIDE HITCH DURING MOUNTING AND PREVENT LOSS OF BOLT / SPACER INSIDE FRAME RAIL.

****NOTE: SOME VEHICLES MAY FISHWIRE THROUGH END OF FRAME****

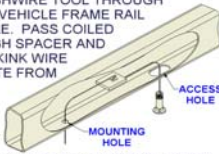
**REVERSE PULL
FISHWIRE TECHNIQUE**

ATTACH FISHWIRE TO CARRIAGE BOLT AND SLIDE SPACER ONTO FISHWIRE. THEN PUSH THE BOLT THRU THE HOLE FOLLOWED BY THE SPACER (AS SHOWN). PULL BOLT BACK INTO POSITION, PROTRUDING FROM THE FRAME.

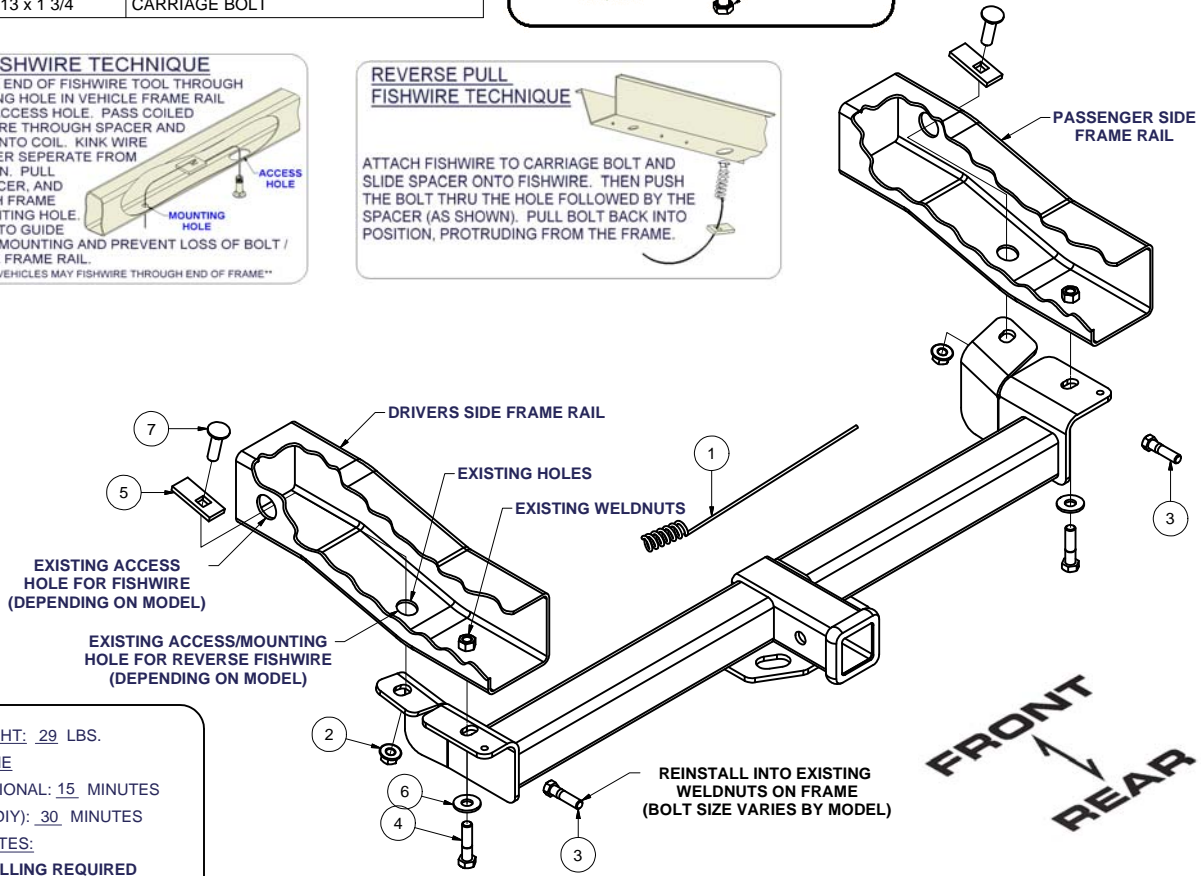
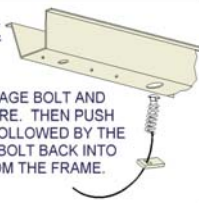
HITCH WEIGHT: 29 LBS.**INSTALL TIME**PROFESSIONAL: 15 MINUTESNOVICE (DIY): 30 MINUTES**INSTALL NOTES:**

- NO DRILLING REQUIRED

INSTALLATION STEPS

1. Remove existing bolt from rear most hole in the vehicle frame. **Note:** These bolts hold bumper in place.
2. Fishwire or reverse fishwire the 1/2" carriage bolts and spacers through access holes and out existing holes in bottom of frame. See Fishwire or Reverse Fishwire Technique.
Note: Access hole locations vary by vehicle.
3. Install remaining fasteners into existing weldnuts, as shown.
Note: Use of the 12mm or 7/16" bolts vary by vehicle.
4. Torque hardware as follows;
7/16" fasteners to 50 lb-ft.
1/2" fasteners to 75 lb-ft.
12mm fasteners to 75 lb-ft.

PERIODICALLY CHECK THIS RECEIVER HITCH TO ENSURE THAT ALL FASTENERS ARE TIGHT AND THAT ALL STRUCTURAL COMPONENTS ARE SOUND.

Curt Manufacturing LLC., warrants this product to be free of defects in material and/or workmanship at the time of retail purchase by the original purchaser. If the product is found to be defective, Curt Manufacturing LLC., may repair or replace the product, at their option, when the product is returned, prepaid, with proof of purchase. Alteration to, misuse of, or improper installation of this product voids the warranty. Curt Manufacturing LLC.'s liability is limited to repair or replacement of products found to be defective, and specifically excludes liability for incidental or consequential loss or damage.