

# 13424 BUICK ENCLAVE, CHEVY TRAVERSE, GMC ACADIA, SATURN OUTLOOK

8/25/2009

GROSS LOAD CAPACITY WHEN USED AS A WEIGHT CARRYING HITCH: 5,000 LBS. TRAILER WEIGHT & 500 LBS. TONGUE WEIGHT.  
 GROSS LOAD CAPACITY WHEN USED AS A WEIGHT DISTRIBUTION HITCH: 6,000 LBS. TRAILER WEIGHT & 600 LBS. TONGUE WEIGHT

**\*\*\*DO NOT EXCEED VEHICLE MANUFACTURER'S RECOMMENDED TOWING CAPACITY.\*\*\***

HAVING INSTALLATION QUESTIONS? CALL TECHNICAL SUPPORT AT 1-800-798-0813

Parts List			
ITEM	QTY	PART NUMBER	DESCRIPTION
1	6	M12-1.75 x 30mm	HEX BOLT
2	6	1/2"	CONICAL TOOTHED WASHER
3	2	1/2-13 x 1 1/4	CARRIAGE BOLT
4	2	CM-SP6	.250 x 1.00 x 3.00" SQ HOLE SPACER
5	2	HFN 1213	HEX FLANGE NUT
6	2	1_2 x 30 FISHWIRE	1/2" x 30" FISHWIRE

TOOLS REQUIRED
19mm SOCKET
10" EXTENSION
RATCHET
TORQUE WRENCH

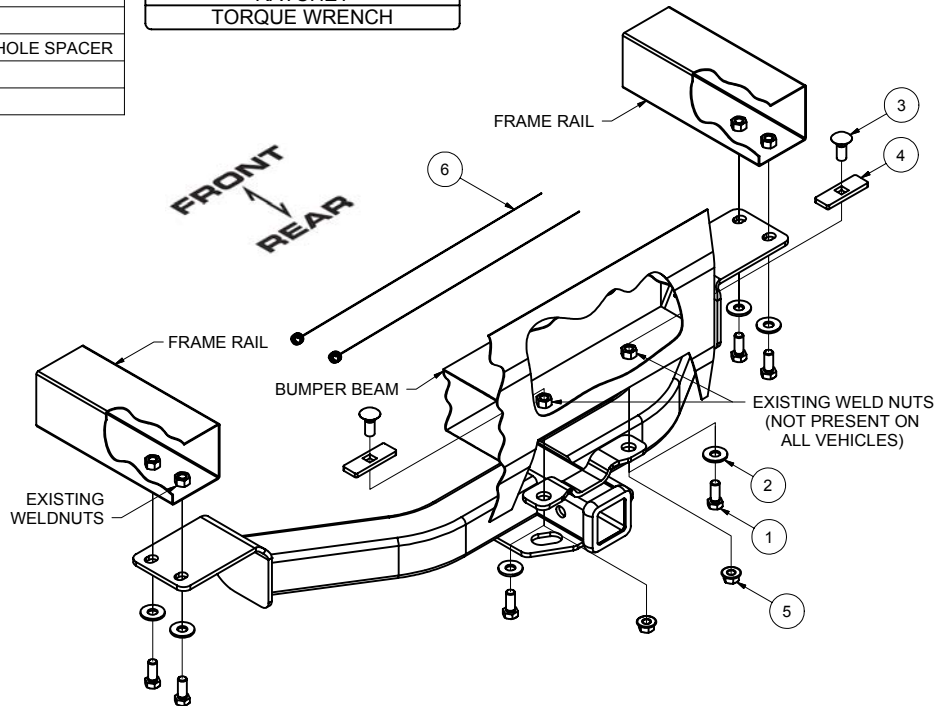
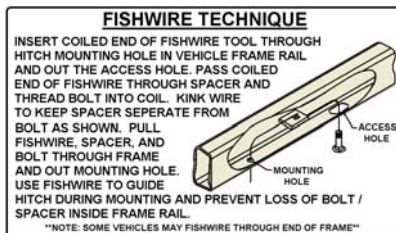
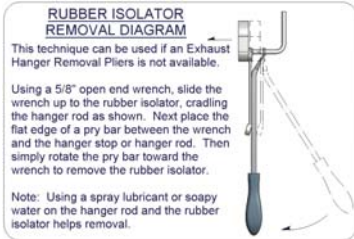

HITCH WEIGHT: 30 LBS.

**INSTALL TIME**

PROFESSIONAL: 30 MINUTES

NOVICE (DIY): 60 MINUTES

**INSTALL NOTES:**

**-NO DRILLING REQUIRED**

## INSTALLATION STEPS

**NOTE:** The weld nuts in the bumper beam used in Step 5 are not present on all vehicles. Carriage bolts, spacers, hex flange nuts and fishwire tools are included in the bolt kit for this purpose.

1. Remove bumper fascia panel. (Note: Panel may be reinstalled on some models after hitch installation if desired.)
2. Lower exhaust to ease installation. (See Rubber Isolator Removal Diagram)
3. Raise hitch into position over the exhaust pipes aligning the slots in the hitch with the weldnuts in the bottom of the frame rails.
4. Install (4) M12 bolts and conical toothed washers through the side plates and into the existing weld nuts in the frame rails as shown.
5. If weldnuts in bumper beam are present, install (2) M12 bolts and conical toothed washers as shown. If the weld nuts are not present, fishwire a 1/2-13 x 1.25" carriage bolt and CM-SP6 spacer into each hole in the bumper beam from the end of the bumper beam and secure with (2) 1/2" hex flange nuts as shown. (See Fishwire Technique.)
6. Torque all M12 hardware to 59 ft-lbs. and all 1/2" hardware to 75 ft-lbs.
7. Raise exhaust back into position, reinstall rubber isolators and fascia panel (if desired).

**PERIODICALLY CHECK THIS RECEIVER HITCH TO ENSURE THAT ALL FASTENERS ARE TIGHT AND THAT ALL STRUCTURAL COMPONENTS ARE SOUND.**

Curt Manufacturing Inc., warrants this product to be free of defects in material and/or workmanship at the time of retail purchase by the original purchaser. If the product is found to be defective, Curt Manufacturing Inc., may repair or replace the product, at their option, when the product is returned, prepaid, with proof of purchase. Alteration to, misuse of, or improper installation of this product voids the warranty. Curt Manufacturing Inc.'s liability is limited to repair or replacement of products found to be defective, and specifically excludes liability for incidental or consequential loss or damage.