

INSTALLATION MANUAL

13486

Level of Difficulty

Easy

Installation difficulty levels are based on time and effort involved and may vary depending on the installer level of expertise, condition of the vehicle and proper tools and equipment.

Weight Carrying Capacity

Gross trailer weight (GTW)	5,000 lbs.
Tongue weight (TW)	750 lbs.

Parts List

Item	Qty	Description
1	6	Hex bolt, M12-1.25 x 40mm
2	6	Conical-toothed washer, 1/2"

Tools Required

Socket, 12mm	Ratchet
Socket, 19mm	Wrench, 1" or larger
Socket extension, 3"	Exhaust removal tool
Torque wrench	Universal joint

* For a tools reference guide visit curtmfg.com/trailer-hitch-installation

⚠ WARNING

Never exceed the vehicle manufacturer's recommended towing capacity.

Product Photo



NOTICE

Visit www.curtmfg.com for a full-color copy of this instruction manual, as well as helpful videos, guides and much more!

Before you begin installation, read all instructions thoroughly.

Proper tools will improve the quality of installation and reduce the time required.

This installation requires:

- Lowering of the spare tire
- Lowering of the exhaust
- Exhaust rod bending

Periodic inspection of the trailer hitch should be performed to ensure all mounting hardware remains tight and structural components are secure.

To help prevent damage to the product or vehicle, refer to the specified torque specifications when securing hardware during the installation process.

SAFETY INSTRUCTIONS

Safety glasses should be worn at all times while installing this product.

Product Registration and Warranty

CURT stands behind our products with industry-leading warranties. To get copies of the product warranties, register your purchase or provide feedback, visit: warranty.curtgroup.com/surveys

ASSEMBLY

Parts List

Item	Qty	Description
1	6	Hex bolt, M12-1.25 x 40mm
2	6	Conical-toothed washer, 1/2"

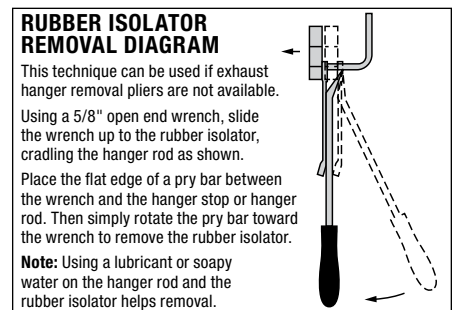
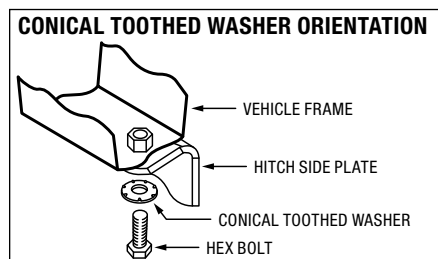
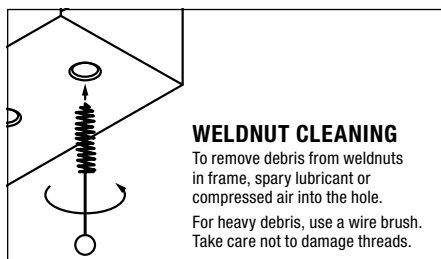
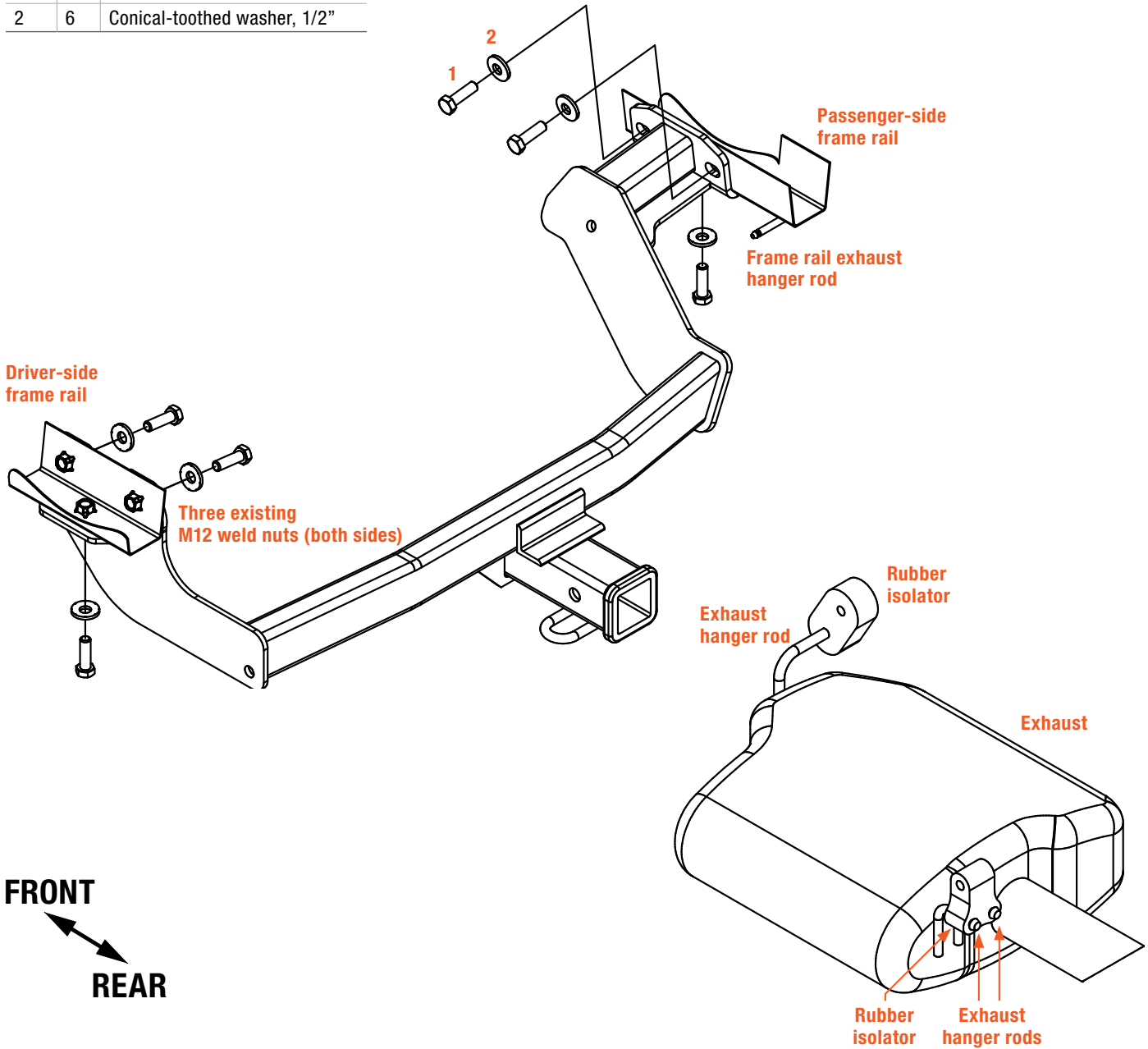

Step 1

Loosen the spare tire carrier nut using a 3/8" socket. Lower the spare tire and set aside for reinstallation in Step 3.



Step 2

Lower the exhaust by removing the three rearmost rubber holders from the exhaust hangers. Use a stand to support the exhaust and prevent any damage.

The exhaust will be reinstalled in Step 3.

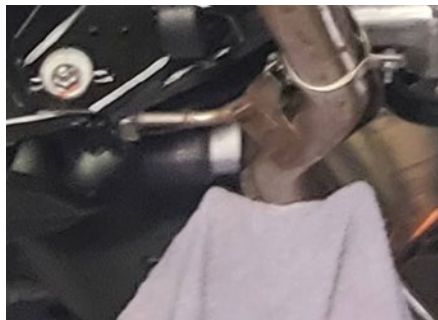
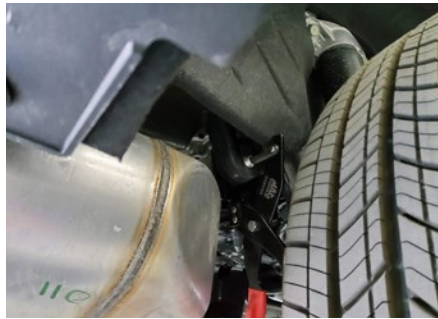

Step 3

Raise the trailer hitch into position by sliding the passenger side of the hitch over the exhaust first. On both sides of the vehicle, align the three holes in the hitch with the three weld nuts in the frame rail.

Loosely install three flange bolts (#1) with the 1/2" conical-toothed washers (#2) into the hitch holes and weld nuts on both sides.

Torque all M12 fasteners to 86 ft-lbs.

Reinstall spare tire and exhaust removed in Steps 1 and 2.

Note: After installation, inspect the hitch and exhaust to make sure there is adequate clearance. If additional clearance is needed between the hitch and exhaust, remove the rearmost rubber isolator from the frame-rail exhaust hanger rod down approximately five degrees using a box end wrench as shown. Reinstall the rubber isolator.



Final Installed Image



TOWING BASICS & SAFETY INFORMATION

For information on safely towing your trailer, visit curtmfg.com/understanding-towing.