

**13511****98-03 TOYOTA SIENNA**

6/11/2009

**GROSS LOAD CAPACITY WHEN USED AS A WEIGHT CARRYING HITCH: 3,500 LBS. TRAILER WEIGHT & 350 LBS. TONGUE WEIGHT.  
 GROSS LOAD CAPACITY WHEN USED AS A WEIGHT DISTRIBUTION HITCH: 4,000 LBS. TRAILER WEIGHT & 400 LBS. TONGUE WEIGHT  
 \*\*\*DO NOT EXCEED VEHICLE MANUFACTURER'S RECOMMENDED TOWING CAPACITY.\*\*\***

Parts List			
ITEM	QTY	PART NUMBER	DESCRIPTION
1	4	M10 - 1.25 x 30	HEX BOLT
2	4	3/8"	WASHER
3	4	7/16	HELICAL LOCK WASHER

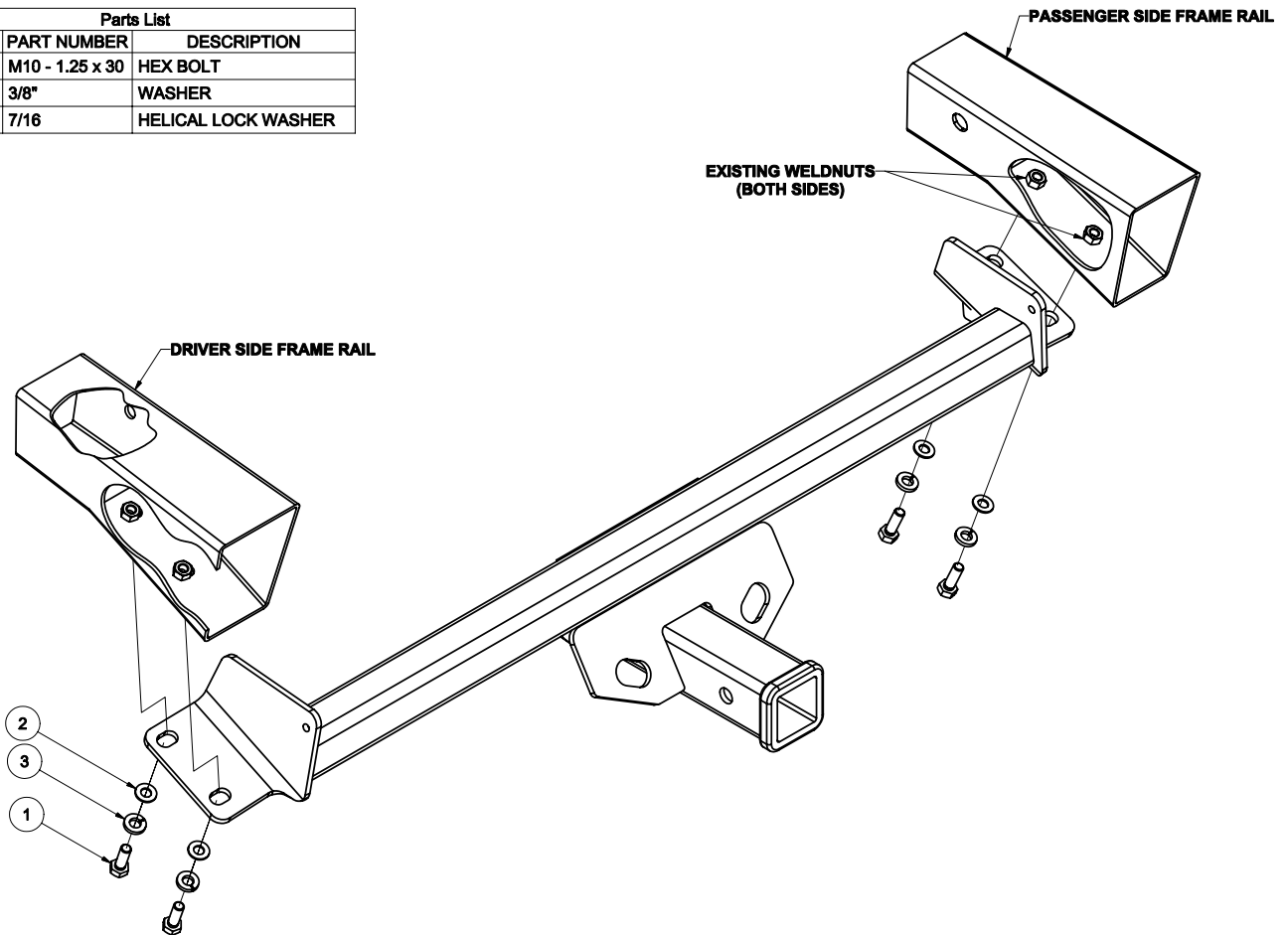

HITCH WEIGHT: 30 LBS.

INSTALL TIME: 30 MINUTES

INSTALL NOTES:

**-NO DRILLING REQUIRED****INSTALLATION STEPS**

- 1) Remove tow hooks if they are present. If tow hooks are not present, remove the 10mm hardware from the existing weldnuts in the frame.
- 2) It may be necessary to lower or remove the spare tire.
- 3) For ease of installation, you may choose to lower the exhaust.
- 4) Raise the hitch into position and attach with the fasteners provided as shown.
- 5) Torque all 10mm fasteners to 38 lb-ft.
- 6) Re-attach the exhaust and return the spare tire to its proper position.

**PERIODICALLY CHECK THIS RECEIVER HITCH TO ENSURE THAT ALL FASTENERS ARE TIGHT AND THAT ALL STRUCTURAL COMPONENTS ARE SOUND.**

Curt Manufacturing Inc., warrants this product to be free of defects in material and/or workmanship at the time of retail purchase by the original purchaser. If the product is found to be defective, Curt Manufacturing Inc., may repair or replace the product, at their option, when the product is returned, prepaid, with proof of purchase. Alteration to, misuse of, or improper installation of this product voids the warranty. Curt Manufacturing Inc.'s liability is limited to repair or replacement of products found to be defective, and specifically excludes liability for incidental or consequential loss or damage.