

FRONT MOUNTED RECEIVER INSTALLATION INSTRUCTIONS

EQUIPMENT REQUIRED:

DRILL BITS: 1/2

HITCH REQUIRES 5/8" PIN AND CLIP IF STABILIZING PIN NOT INSTALLED

WRENCHES: (TIGHTEN ALL FASTENERS WITH TORQUE WRENCH)

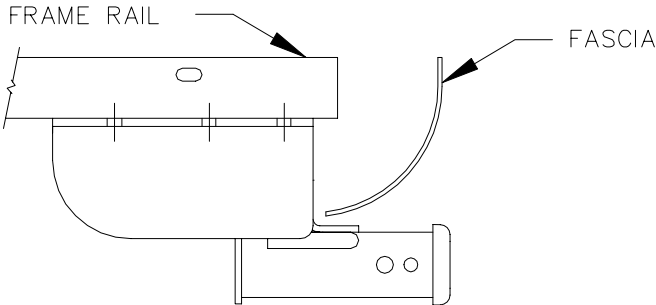

HITCH SHOWN IN PROPER POSITION

DRILLED HOLE

EXISTING SLOTS

FRAME RAIL

M12 X 1.25 X 40mm CL10.9
LOCK WASHER
NUT BLOCK HANDLE ASSEMBLY

M12 X 1.25 X 40mm CL10.9
CONICAL TOOTHED WASHER
NUT BLOCK HANDLE ASSEMBLY

CARGO CAPACITY – DO NOT EXCEED
500 LB. OR VEHICLE FRONT GROSS
AXLE WEIGHT RATING. (GAWR)

9000 LB. MAX. WINCH LINE PULL

OPTIONAL LOCKING STABILIZING PIN

J-PIN

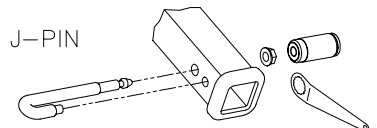

(Order Separately)

1. RAISE RECEIVER INTO POSITION AND INSTALL FASTENERS IN FOUR (4) EXISTING SLOTS AS SHOWN.
NOTE: ON FORD EXPLORER AIR DAM CAN BE TRIMMED FOR BETTER TOW HOOK CLEARANCE.
2. USING RECEIVER AS TEMPLATE DRILL ONE (1) HOLE IN EACH FRAME RAIL AS SHOWN.
3. INSTALL REMAINING FASTENERS.

TIGHTEN ALL M12 CL10.9 FASTENERS TO 92 LB-FT.

APPROX WEIGHT: 32 LB. / 14.5 KG

NOTE: Check receiver frequently, making sure all fasteners are properly tightened. A receiver which has been damaged should be removed and replaced. Observe safety precautions when working beneath a vehicle and wear eye protection.

WARNING: DO NOT CUT ACCESS OR ATTACHMENT HOLES WITH A TORCH.
DO NOT CUT, WELD, OR MODIFY RECEIVER.

Reese Products, INC.
Elkhart, IN.
Oakville, ONT. Canada